

第三角法
3rd ANGLE PROJECTION

単位: mm 注) 図面を実測しないこと
UNIT: mm NOTES) DO NOT SCALE

図番 DRAWING No.
JC-1011-38

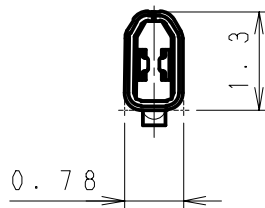
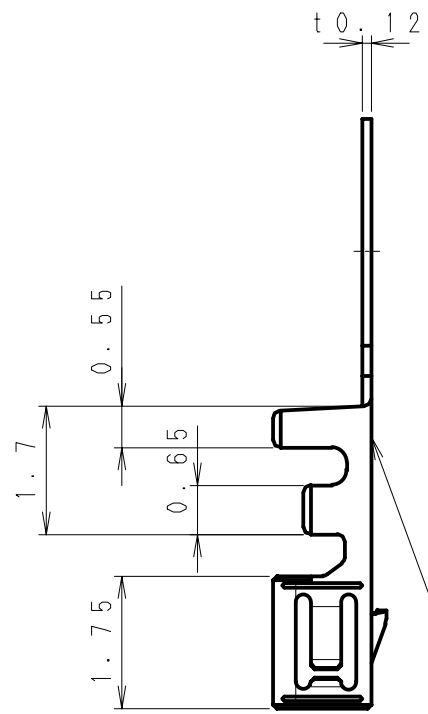
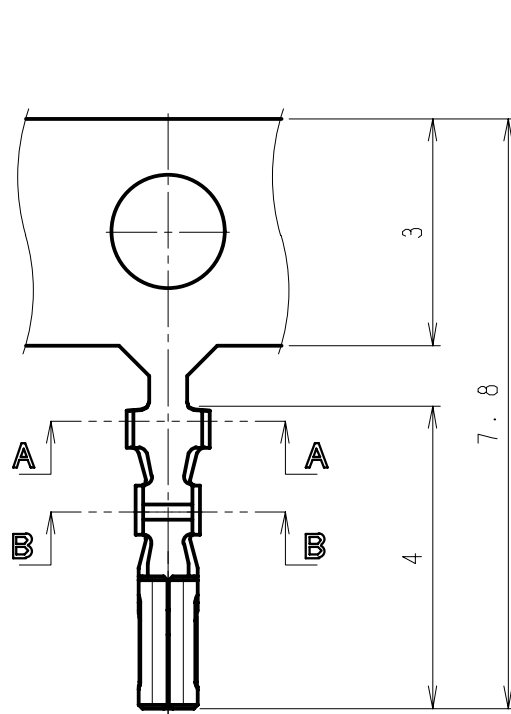

型No刻印(1~5) 1又は1
Model No. mark(1~5) 1 or 1

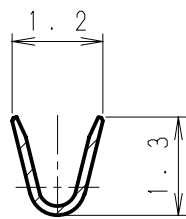

SEC A-A

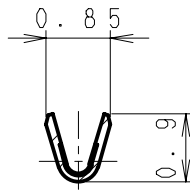

SEC B-B

④	. .				710112-2MAC	リン青銅 Phosphor Bronze	スズメッキ材 Pre-tin Plated	AWG#28~#32	② φ0.54~φ0.88
③	. .				製品番号 PRODUCT No.	材 料 MATERIAL	表面処理 FINISH	適用電線 WIRE SIZE	被覆外径 INSULATION DIA
②	14. 4. 17	最小被覆外径追記 Add the minimum of the insulation cover	清水 草野						
①	12. 8. 22	表記の統一 Unification of the notation	小泉 草野						
記号 No.	年月日 DATE	変更記事 REVISION RECORD	設計 DESIGN	承認 APP	製品名 NAME		ターミナル Terminal		
承認 APPROVED	K. Kusano		確認 CHECKED	K. Koizumi		一般公差 TOLERANCE	尺度 SCALE	図番 DRAWING No.	
				±0.3		10 / 1		JC-1011-38	
設計 DESIGN	A. Kumakura		製図 DRAWING	A. Kumakura		JAPAN AUTOMATIC MACHINE CO., LTD.			