

御中

製品仕様書  
Product specifications

製品名 Product Name	RJWコネクタ RJW connector	
製品番号 Product Number	ターミナル Terminal	720467-2MAC
		720468-2MAC
	RECハウジング REC Housing	RJW20-□□M※※
	PLUGハウジング PLUG Housing	SJW2K-□□HG※※

受領印欄  
Acknowledged

日本オートマチックマシン株式会社  
電子部品事業部 製品技術G  
〒146-0092 東京都大田区下丸子3-28-4  
TEL 03(3756)1435

JAPAN AUTOMATIC MACHINE CO., LTD  
Product Engineering Group Electronic Parts Headquarters  
3-28-4, Shimomaruko, Ota-ku, Tokyo 146-0092, Japan

※ RoHS対応品  
This product corresponds to RoHS.

## &lt;変更履歴表&gt; ALTERATION HISTORY RECORDS

履歴 Revision	日付 Date	変更内容 Contents of Alteration	変 更 Change	承 認 Approved
制定 Issue	2017. 7. 6	—	大垣	草野
△				
△				
△				
△				
△				
△				
△				
△				
△				
△				
△				
△				
△				

## &lt;目次&gt; INDEX

1. 適用範囲 (Scope)
2. 製品名・製品番号 (Product name and number)
3. 形状・寸法・材料 (Geometry and materials)
4. 定格 (Rated values)
5. 性能 (Performances)
6. 梱包・表示 (Packing and marking)
7. 品番構成 (Product No. code)

## 仕 様 書 Specifications

SA-1461S16-A0-3/13

## 1. 適用範囲 (Scope)

この製品仕様書は「R J Wコネクタ」の一般仕様及び性能について規定する。  
The present document concerns general specifications and performances of  
"RJW connector".

## 2. 製品名・製品番号 (Product name and number)

製品名 Product Name	製品番号 Number	材料及び表面処理 Material and surface treatment
ターミナル Terminal	7 2 0 4 6 7 - 2 M A C	リン青銅 スズメッキ材
	7 2 0 4 6 8 - 2 M A C	Phosphor Bronze, Pre-tin Plated
RECハウジング REC housing	R J W 2 0 - □ □ M ※ ※	ナイロン 6 6 (UL94V-0)
PLUGハウジング PLUG housing	S J W 2 K - □ □ H G ※ ※	Nylon 66 (UL94V-0)

## 3. 形状・寸法・材料 (Geometry and materials)

添付図面による。  
Refer to attached drawings.

図面番号 Drawing No.	製品名 Product name	記号 Mark
J C - 0 9 4 8 - 2 4	R J Wコネクタ RJW Connector	8~20P 0
J C - 0 9 4 8 - 2 5	R J Wコネクタ RJW Connector	22~40P 0
J C - 0 9 4 8 - 2 0	R J Wハウジング RJW Housing	8~20P 0
J C - 0 9 4 8 - 2 1	R J Wハウジング RJW Housing	22~40P 0
J C - 1 0 7 2 - 0 5	S J Wハウジング SJW Housing	8~18P 0
J C - 1 0 7 2 - 0 6	S J Wハウジング SJW Housing	20~40P 0
J C - 0 9 4 8 - 0 5	ターミナル Terminal	0
J C - 0 9 1 1 - 2 1	ターミナル Terminal	△

## 4. 定格 (Rated values)

項目 Item	規格値 Description
定格電圧 Rated voltage	250V AC, DC
定格電流 (注1) Rated current (Note 1)	3A
使用温度範囲 Temperature range	-25 ~ +85°C (通電による温度上昇分を含む) -25 to +85°C (heating by energization included)
適用電線範囲 (注2) Wire size (Note 2)	AWG #22 ~ #28 最大被覆外径 $\phi$ 1.5mm AWG #22 to #28 Maximum diameter of insulation covering $\phi$ 1.5 mm
保存温度 Storage temperature	-30 ~ +60°C (90%RH以下) -30 to +60°C (90% RH or less)

(注1) 定格電流はターミナル接触部の定格値であり、実使用においては使用電線の定格電流、使用温度により決定される。

(注2) 電線はより線を使用し、単線等の特殊電線は原則として使用出来ません。

(Note 1) The rated current shown is at the terminal contact section. Practically, it varies depending on rated current of particular wire and operating temperature.

(Note 2) Use a stranded wire. Do not use solid or other special wires.

## 5. 性能 (Performances)

性能は、下表に示す試験条件及び方法で試験を実施したとき、各項目に規定する規格値を満足すること。尚、試験は特に指定のない限り JIS C 60068-1 [環境試験方法 (電気、電子)通則] に規定された試験場所の標準にて実施する。

The performances tested under the conditions and methods given in the table below shall conform to the respective specifications. Unless otherwise specified, carry out the tests according to the standards of a place of test stipulated in IEC 60068-1 "General Rules of Environmental Testing Method (Electric and Electronic)".

## 5-1 外観 (Appearance)

No.	項目 Item	規格値 Description	条件 Check
5-1-1	外観 Appearance	使用上有害となる様な割れ・変形等が無いこと Crack, deformation, etc. harmful in use are not allowed	目視 Visual

## 5-2 機械的性能 (Mechanical properties)

No.	項目 Item	規格値 Description	試験条件及び方法 Check
5-2-1	挿入力 Insertion force	別表A参照 See Appended Table A	ターミナルを各々のハウジングに装着し、リセハウジングへのプラグハウジング挿入力を、測定する。 試験速度 25mm/min  Inserting the terminal into each housing, measure the force required for inserting the PLUG housing into REC housing at 25 mm/min.
5-2-2	保持力 Pull-out force	別表A参照 See Appended Table A	ターミナルを各々のハウジングに装着し、ロックを除去してリセハウジングとの保持力を測定する。 試験速度 25mm/min  Inserting the terminal into each housing, unlock the housing, and measure the pull-out force of REC housing at 25 mm/min.
5-2-3	ハウジングロック 保持力 Housing locking power	29.4 N以上 29.4 N or more	ターミナルを挿入しない状態で、リセハウジングとプラグハウジングを嵌合させ、プラグハウジングを引張り、ロックが外れるときの力を測定する。 試験速度 100mm/min  Terminal is not inserted, engage the REC housing and plug housing with each other, and pull the PLUG housing at 100 mm/min until unlocked. Take the reading at this point.
5-2-4	圧着部引張強度 Tensile strength of crimped section	電線 Wire size 強度 N 以上 Minimum strength in N	ターミナルのワイヤバレルと電線導体を圧着し、治具で固定し電線の軸方向に引っ張る。 試験速度 25mm/min  Crimp the terminal's wire barrel and conductor together, fasten the altogether, and pull the wire axially at 25 mm/min.
		AWG#22	44.1
		AWG#24	29.4
		AWG#26	19.6
		AWG#28	9.8

No.	項目 Item	規格値 Description	試験条件及び方法 Check
5-2-5	ターミナル 挿入力  Terminal insertion force	6.9 N 以下  6.9 N or less	ターミナルをハウジングに挿入するの に要する力を万能試験機を用いて測定 する。 試験速度 25mm/min  Using universal testing machine, measure the force required for inserting the terminal into housing at 25 mm/min.
5-2-6	ターミナル 保持力  Terminal pull-out force	9.8 N 以上  9.8 N or more	ハウジングに装着したターミナルを軸 方向に引張り、ハウジングからターミ ナルが離脱するときの荷重を万能試験 機を用いて測定する。 試験速度 25mm/min  Using universal testing machine, pull the terminal axially at 25 mm/min until it leaves the housing. Take the reading at this point.

## 5-3 電气的性能 (Electrical characteristics)

No.	項目 Item	規格値 Description	試験条件及び方法 Check
5-3-1	接触抵抗 Contact resistance	初期 10 mΩ 以下 10 mΩ or less initially	コネクタを嵌合状態にして電気抵抗を測定し、電線抵抗を差し引いて接触抵抗とする。 試験電流 15mA (20mV以下) Engage the connector, measure the overall resistance at 15 mA and 20 mV or less and, from the reading, subtract the wire resistance. Retain the difference as contact resistance.
5-3-2	絶縁抵抗 Insulation resistance	1000 MΩ 以上 1000 MΩ or more	コネクタ外面とターミナル相互間及び隣接するターミナル間にDC500Vを印可して測定する。 Apply 500 V DC between connector housing and each of terminals, and between adjacent terminals.
5-3-3	耐電圧 Dielectric strength	AC 1000V / 1分間 異常なきこと AC 1000V / 1min. Shall remain normal	ハウジング外面とターミナル相互間及び隣接するターミナル間にて測定する。 Apply 1000 V AC for 1 min between connector housing and each of terminals, and between adjacent terminals.
5-3-4	温度上昇 Temperature rise	30 K 以下 (適用最大電線による) 30 K or less (With thickest applicable wire)	ハウジングの全極にターミナルを装着し、嵌合させて各ターミナルを直列に接続し、最大定格電流を通電した時のターミナル部の温度上昇を測定する。 Mount the terminals on all housing poles, engage them, connect all terminals in series, apply rated current, and measure the temperature at terminals.

## 5-4 耐久環境性能 (Durability)

No.	項目 Item	規格値 Description		試験条件及び方法 Check
5-4-1	挿抜寿命 Engagement and disengagement	接触抵抗 Contact resistance	20 mΩ 以下 20 mΩ or less	ハウジングにターミナルを装着し、RECハウジングにPLUGハウジングを挿抜(30回)試験前後の接触抵抗を測定する。  Mount the terminals on housing, Repeat 30 cycles of insertion and removal of REC housing and PLUG housing, and measure the contact resistance.
		外観 Appearance	異常なきこと Shall remain normal	
5-4-2	耐振動性 Vibration	接触抵抗 Contact resistance	20 mΩ 以下 20 mΩ or less	コネクタを結合し、下記条件にて振動試験実施。 掃引割合 10~55~10Hz 掃引時間 1分 最大振幅 1.5 mm 振動軸方向 X、Y、Z 振動時間 各2時間=6時間  Engage the connector, and carry out tests under following conditions. Sweep frequency 10-55-10 Hz. Sweep time 1 min. Maximum amplitude 1.5 mm. Vibration axes X, Y, Z. Vibration time 2 h each or totally 6 h.
		電流瞬断 Momentary failure	1 μs 以下 1 μ sec or less	
		外観 Appearance	異常なきこと Shall remain normal	
5-4-3	耐熱性 Heating	接触抵抗 Contact resistance	20 mΩ 以下 20 mΩ or less	コネクタを結合後、下記条件に放置 雰囲気温度 100 ± 5℃ 放置時間 240時間 室内で1~2時間放置後測定  Engage the connector, and keep the sample for 240 h under following conditions. Ambient temperature 100 ± 5°C. Leave the sample at the room for 1 to 2 h before check.
		外観 Appearance	異常なきこと Shall remain normal	
5-4-4	耐寒性 Cold	接触抵抗 Contact resistance	20 mΩ 以下 20 mΩ or less	コネクタを結合後、下記条件に放置 雰囲気温度 -40 ± 2℃ 放置時間 240時間 室内で1~2時間放置後測定  Engage the connector, and keep the sample for 240 h under following conditions. Ambient temperature -40 ± 2°C. Leave the sample at the room for 1 to 2 h before check.
		外観 Appearance	異常なきこと Shall remain normal	



No.	項目 Item	規格値 Description		試験条件及び方法 Check
5-4-5	耐熱衝撃性 Heat shock	接触抵抗 Contact resistance	20 mΩ 以下 20 mΩ or less	コネクタを結合後、下記条件に放置 1. 低温側 $-40 \pm 2^{\circ}\text{C}$ 30分 2. 室温 $+25 \pm 10^{\circ}\text{C}$ 10分 3. 高温側 $+85 \pm 2^{\circ}\text{C}$ 30分 4. 室温 $+25 \pm 10^{\circ}\text{C}$ 10分 1～4を25サイクル行う。  Engage the connector, and subject it to 25 cycles of following sequence. 1. Low temperature $-40 \pm 2^{\circ}\text{C}$ for 30 min. 2. Room temperature $+25 \pm 10^{\circ}\text{C}$ within 10 min. 3. High temperature $+85 \pm 2^{\circ}\text{C}$ for 30 min. 4. Room temperature $+25 \pm 10^{\circ}\text{C}$ within 10 min.
5-4-6	耐湿性 Moisture	接触抵抗 Contact resistance	20 mΩ 以下 20 mΩ or less	コネクタを結合後、下記条件に放置 雰囲気温度 $60 \pm 2^{\circ}\text{C}$ 相対湿度 90～95% RH 放置時間 240時間 室内で1～2時間放置後測定  Engage the connector, and keep the sample for 240 h under following conditions. Ambient temperature $60 \pm 2^{\circ}\text{C}$ . Relative humidity 90 to 95%. Leave the sample at the room for 1 to 2 h before check.
		絶縁抵抗 Insulation resistance	500MΩ 以上 500 MΩ or more	
		耐電圧 Dielectric strength	AC500V/ 1分間 異常なきこと Shall remain normal at 500 V AC for 1 min	
		外観 Appearance	異常なきこと Shall remain normal	

No.	項目 Item	規格値 Description		試験条件及び方法 Check
5-4-7	耐塩水噴霧性 Salt mist	接触抵抗 Contact resistance	20 mΩ 以下 20 mΩ or less	コネクタを結合後、下記条件に放置 温 度 35 ± 2℃ 塩水濃度 5 ± 1% (重量比) 噴霧時間 48時間 接触抵抗測定は、水洗をし室温で乾燥 させてから、1～2時間放置後測定。  Engage the connector, and keep the sample under following conditions. Temperature 35 ± 2°C. Salt concentration 5 ± 1%wt. Spray time 48 h. Then, rinse the sample, and leave it dry at room temperature for 1 to 2 h.
		外観 Appearance	異常なきこと Shall remain normal	
5-4-8	耐アンモニア性 Ammonia	接触抵抗 Contact resistance	20 mΩ 以下 20 mΩ or less	コネクタを結合後、下記アンモニア水 の入ったデシケータ容器中に放置 濃 度 28% 温 度 25℃ 容 積 比 25 ml / ℓ 放置時間 40分 室内で1～2時間放置後測定。  Engage the connector, and keep it in desiccator filled with following aqueous ammonia for 40 min. Concentration 28%. Temperature 25°C. Volume ratio 25 ml / ℓ Leave the sample at the room for 1 to 2 h before check.
		外観 Appearance	異常なきこと Shall remain normal	
5-4-9	耐硫化水素ガス性 Hydrogen sulfide	接触抵抗 Contact resistance	20 mΩ 以下 20 mΩ or less	コネクタを結合後、下記硫化水素ガス 中に放置。 濃 度 3 ± 1 ppm 温 度 40 ± 2℃ 放置時間 96時間 室内で1～2時間放置後測定。  Engage the connector, and keep it in hydrogen sulfide for 96 h. Density 3 ± 1 ppm. Temperature 40 ± 2°C. Leave the sample at the room for 1 to 2 h before check.
		外観 Appearance	異常なきこと Shall remain normal	

## 6. 梱包・表示 (Packing and marking)

## 6-1 ターミナル (Terminals)

ターミナルはリールに巻き、さらにダンボール箱に梱包して出荷。  
表示はリールに型番、数量、ロットNo. を明記したラベルを貼り付ける。  
Wind the terminals on reel, and pack it in cardboard case for shipment.  
As indications, attach a label filled with product number, quantity and lot No. onto reel.

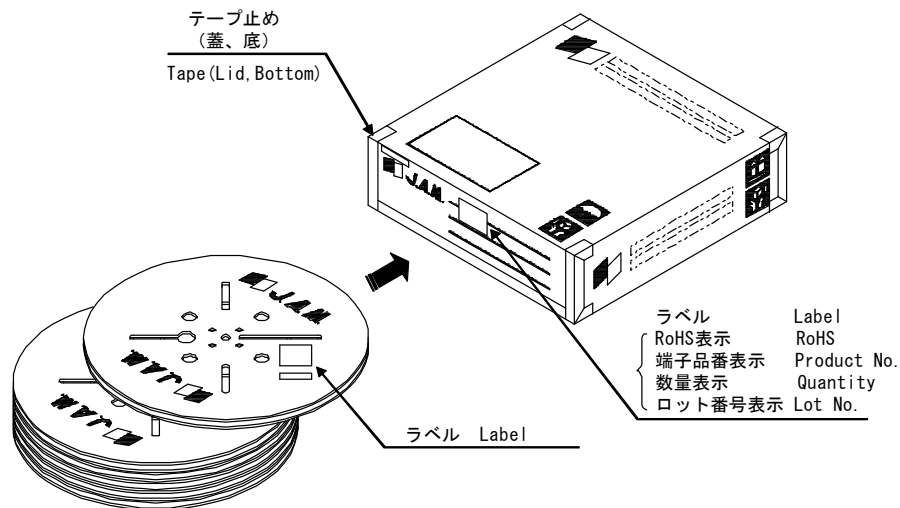

## 6-2 ハウジング (Housings)

ナイロン袋に入れ、さらに、ダンボール箱に梱包して出荷。  
表示はナイロン袋、ダンボール箱に型番、数量、ロットNo. を明記したラベルを貼り付ける。  
Put the housings in nylon bag, and pack it in cardboard case for shipment.  
As indications, attach labels filled with product number, quantity and lot No. onto nylon bag and cardboard case.

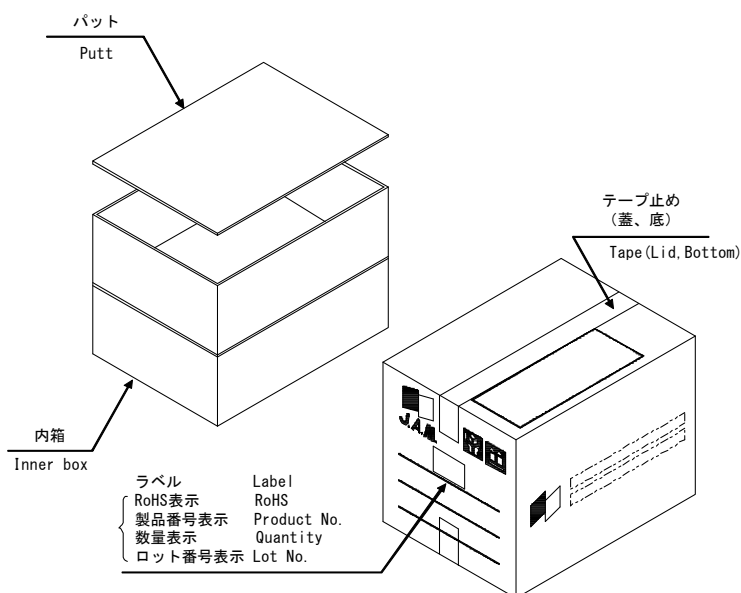

## 7. 品番構成 (Product No. code)

## 7-1 ターミナル (Terminals)

7 2 0 4 6 □ - 2 M A C

材質種別記号 (Material)

紙巻き (Paper winding)

スズメッキ材 (Pre tin-plated)

シリーズNo. (Series No.)

7 2 0 4 6 7 : ピンターミナル (Pin terminal)

7 2 0 4 6 8 : ソケットターミナル (Socket terminal)

## 7-2 R J Wハウジング (RJW housing)

R J W 2 0 - □ □ M ※※

色記号 (Color)

製品種別 (Product type)

M : R E Cハウジング (REC housing)

極数 (Poles)

0 8 : 8 極 (08: 8 poles)

ゝ ゝ

4 0 : 4 0 極 (40: 40 poles)

シリーズNo. (Series No.)

## 7-3 S J Wハウジング (SJW housing)

S J W 2 K - □ □ H G ※※

色記号 (Color)

製品種別 (Product type)

H G : P L U Gハウジング (PLUG housing)

極数 (Poles)

0 8 : 8 極 (08: 8 poles)

ゝ ゝ

4 0 : 4 0 極 (40: 40 poles)

シリーズNo. (Series No.)

## 仕 様 書 Specifications

SA-1461S16-A0-13/13

&lt;色記号&gt; &lt;Color&gt;

記号 Symbol	無 None	RE	PK	BR	GY	YG
色 Name	白 White	赤 Red	桃 Pink	紫 Purple	灰 Gray	若草 Yellowish green

記号 Symbol	YL	OR	BW	BL	GR	BK
色 Name	黄 Yellow	橙 Orange	茶 Brown	青 Blue	緑 Green	黒 Black

記号 Symbol	LY		LP		LO	
色 Name	蛍光黄 Fluorescence yellow		蛍光桃 Fluorescence pink		蛍光橙 Fluorescence orange	

※ JAMでの標準色は白色です。

The standard color in JAM is white.

## 【表A】挿入力及び保持力

(Table A: Insertion force and pull-out force)

極数 Poles	挿入力(N以下) Maximum insertion force in N	保持力(N以上) Minimum pull-out force in N
8P	20.0	2.4
10P	25.0	3.0
12P	30.0	3.6
14P	35.0	4.2
16P	40.0	4.8
18P	45.0	5.4
20P	50.0	6.0
22P	55.0	6.6
24P	60.0	7.2
26P	65.0	7.8
28P	70.0	8.4
30P	75.0	9.0
32P	80.0	9.6
34P	85.0	10.2
36P	90.0	10.8
38P	95.0	11.4
40P	100.0	12.0

製造元：

日本オートマチックマシン株式会社

Manufacturer：

JAPAN AUTOMATIC MACHINE CO., LTD.

Poles	A	B	C
8	6.0	10.0	10.8
10	8.0	12.0	12.8
12	10.0	14.0	14.8
14	12.0	16.0	16.8
16	14.0	18.0	18.8
18	16.0	20.0	20.8
20	18.0	22.0	22.8

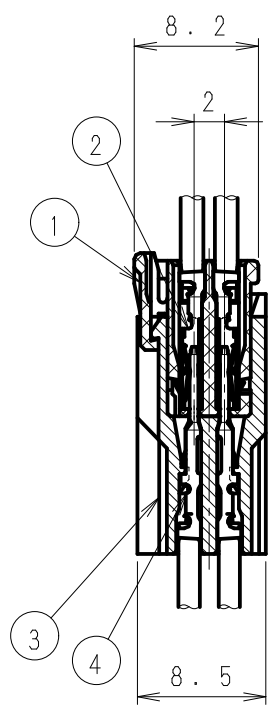
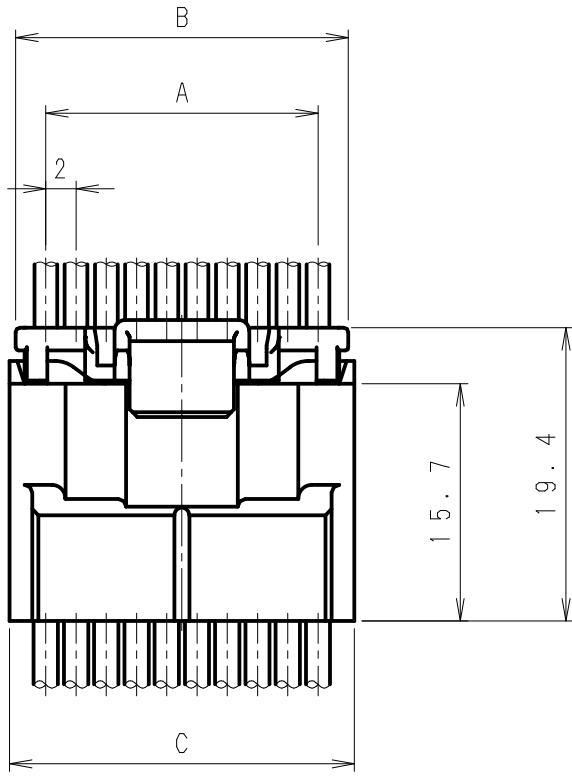

No.	製品番号 Product No.	製品名 Product Name	材質 Material
①	SJW2K-□□HG	SJWハウジング SJW Housing	ナイロン66 Nylon66
②	720468-2MAC	ターミナル Terminal	リン青銅 Phosphor Bronze
③	RJW20-□□M	RJWハウジング RJW Housing	ナイロン66 Nylon66
④	720467-2MAC	ターミナル Terminal	リン青銅 Phosphor Bronze

極数 Poles	8 ~ 20
適用電線 Wire Size	AWG #22 ~ #28
被覆外径 Insulation Dia.	MAX φ 1.5 mm

△6	. .								
△5	. .								
△4	. .								
△3	. .								
△2	. .								
△1	17.7.6	アイテム追加 Item addition	大垣 草野	製品番号 PRODUCT No.	材 料 MATERIAL	表面処理 FINISH	適用電線 WIRE SIZE	被覆外径 INSULATION DIA	
記号 No.	年月日 DATE	変更記事 REVISION RECORD	設計 承認 DESIGN APP	製品名 NAME		RJWコネクタ RJW Connector			
承認 APPROVED	確認 CHECKED		一般公差 TOLERANCE	尺度 SCALE	図番 DRAWING No.				
K. Kusano	A. Kumakura		±0.3	2/1	JC-0948-24				
設計 DESIGN	製図 DRAWING								
A. Kumakura	Y. Shimizu								

Poles	A	B	C	Poles	A	B	C
22	20.0	24.0	24.8	32	30.0	34.0	34.8
24	22.0	26.0	26.8	34	32.0	36.0	36.8
26	24.0	28.0	28.8	36	34.0	38.0	38.8
28	26.0	30.0	30.8	38	36.0	40.0	40.8
30	28.0	32.0	32.8	40	38.0	42.0	42.8

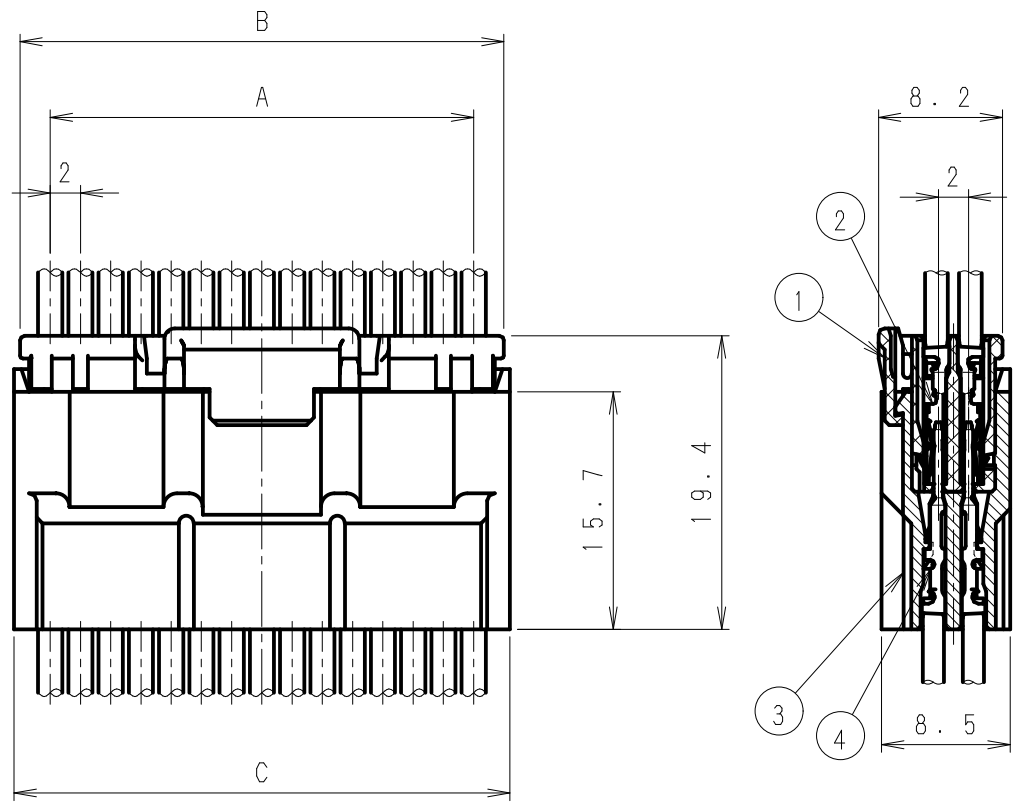

No.	製品番号 Product No.	製品名 Product Name	材質 Material
①	SJW2K-□□HG	SJWハウジング SJW Housing	ナイロン66 Nylon66
②	720468-2MAC	ターミナル Terminal	リン青銅 Phosphor Bronze
③	RJW20-□□M	RJWハウジング RJW Housing	ナイロン66 Nylon66
④	720467-2MAC	ターミナル Terminal	リン青銅 Phosphor Bronze

極数 Poles	22~40
適用電線 Wire Size	AWG#22~#28
被覆外径 Insulation Dia.	MAXφ1.5mm

△6	. .								
△5	. .								
△4	. .								
△3	. .								
△2	. .			製品番号 PRODUCT No.	材 料 MATERIAL	表面処理 FINISH	適用電線 WIRE SIZE	被覆外径 INSULATION DIA	
△1	. .								
記号 No.	年月日 DATE	変更記事 REVISION RECORD	設計 DESIGN	承認 APP	製品名 NAME		RJWコネクタ RJW Connector		
承認 APPROVED	確認 CHECKED		一般公差 TOLERANCE		尺度 SCALE	図番 DRAWING No.			
K. Kusano	A. Kumakura		±0.3		2/1	JC-0948-25			
設計 DESIGN	製図 DRAWING								
A. Kumakura	Y. Shimizu								

第三角法  
rd ANGLE PROJECTION

単位: mm  
UNIT: mm

注) . . . . 図面を実測しないこと  
NOTES) . . . . DO NOT SCALE

図番 DRAWING No.  
JC-0948-20

製品番号	A	B	C
RJW20-08M	6.0	8.8	10.8
RJW20-10M	8.0	10.8	12.8
RJW20-12M	10.0	12.8	14.8
RJW20-14M	12.0	14.8	16.8
RJW20-16M	14.0	16.8	18.8
RJW20-18M	16.0	18.8	20.8
RJW20-20M	18.0	20.8	22.8

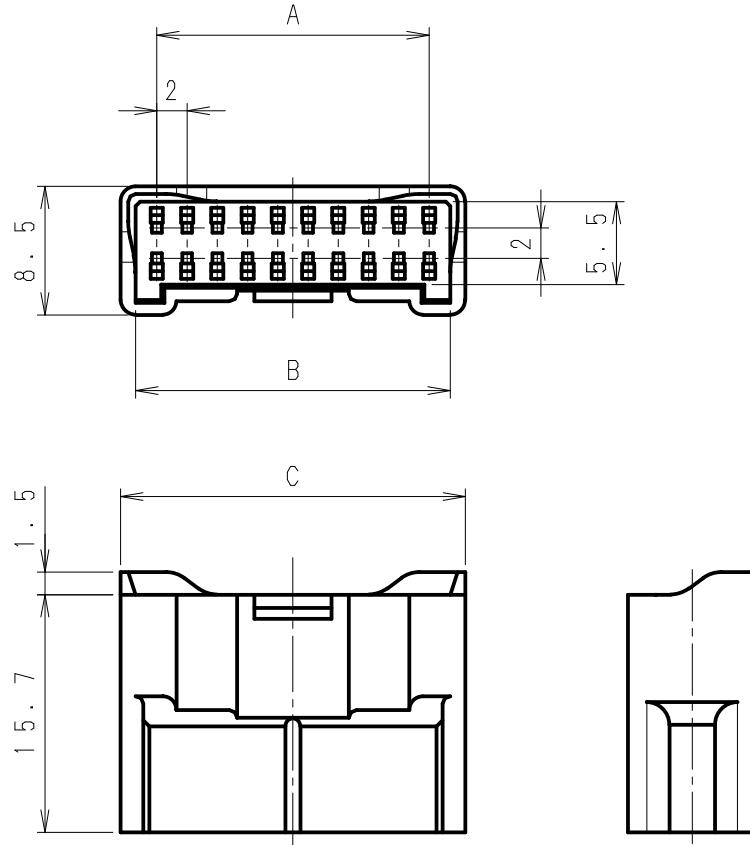

2極目及び、キャビNo. 刻印  
2nd Pole No. Mark Cav No. Mark

"JAM"社名及び、1極目刻印  
"JAM" Mark 1st Pole No. Mark

最終極番刻印  
Last Pole No. Mark

最終極番-1刻印  
Last Pole No.-1 Mark

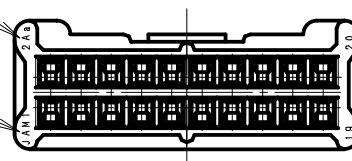

△6	. .								
△5	. .								
△4	. .								
△3	. .				RJW20-□□M		ナイロン66 Nylon66		
△2	. .				製品番号 PRODUCT No.	No.	材 料 MATERIAL	備考 NOTE	
△1	. .							色 COLOR	
記号 No.	年月日 DATE	変更記事 REVISION RECORD	設計 DESIGN	承認 APP	製品名 NAME			RJWハウジング RJW Housing	
承認 APPROVED	確認 CHECKED		一般公差 TOLERANCE		尺度 SCALE	図番 DRAWING No.			
K. Kusano	K. Koizumi		±0.3		2/1	JC-0948-20			
設計 DESIGN	製図 DRAWING								
A. Kumakura	A. Kumakura								



第三角法  
rd ANGLE PROJECTION

単位：mm 注) . . . . 図面を実測しないこと  
UNIT: mm NOTES) . . . . DO NOT SCALE

図番 DRAWING No.  
JC-0948-21

製品番号	A	B	C	製品番号	A	B	C
RJW20-22M	20.0	22.8	24.8	RJW20-32M	30.0	32.8	34.8
RJW20-24M	22.0	24.8	26.8	RJW20-34M	32.0	34.8	36.8
RJW20-26M	24.0	26.8	28.8	RJW20-36M	34.0	36.8	38.8
RJW20-28M	26.0	28.8	30.8	RJW20-38M	36.0	38.8	40.8
RJW20-30M	28.0	30.8	32.8	RJW20-40M	38.0	40.8	42.8

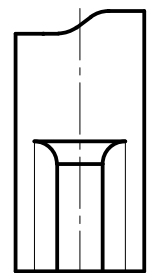
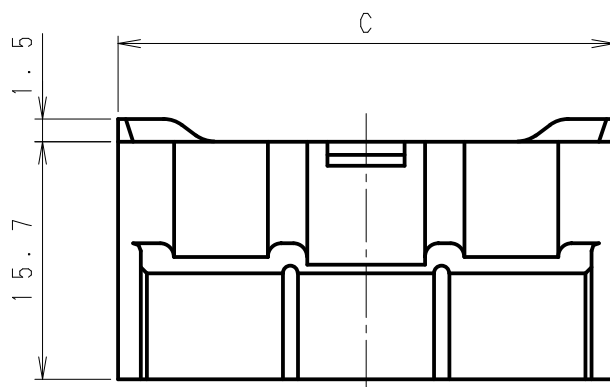
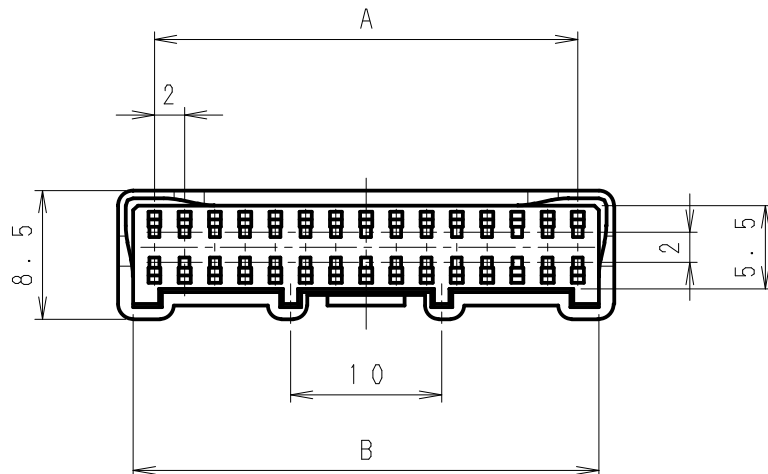

2極目及び、キャビNo. 刻印  
2nd Pole No. Mark Cav No. Mark

"JAM" 社名及び、1極目刻印  
"JAM" Mark 1st Pole No. Mark

最終極番刻印  
Last Pole No. Mark

最終極番-1刻印  
Last Pole No.-1 Mark

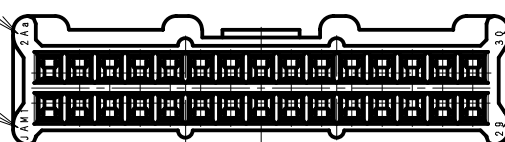

△6	. .								
△5	. .								
△4	. .								
△3	. .				RJW20-□□M		ナイロン66 Nylon66		
△2	. .				製品番号 PRODUCT No.	No.	材 料 MATERIAL	備考 NOTE	
△1	. .							色 COLOR	
記号 No.	年月日 DATE	変更記事 REVISION RECORD	設計 DESIGN	承認 APP	製品名 NAME			RJWハウジング RJW Housing	
承認 APPROVED	確認 CHECKED		一般公差 TOLERANCE		尺度 SCALE	図番 DRAWING No.		JC-0948-21	
K. Kusano		K. Koizumi		±0.3		2/1			
設計 DESIGN		製図 DRAWING							
A. Kumakura		A. Kumakura							

Poles	A	B	C	D
8	6.0	8.8	10.0	4.0
10	8.0	10.8	12.0	6.0
12	10.0	12.8	14.0	6.9
14	12.0	14.8	16.0	
16	14.0	16.8	18.0	
18	16.0	18.8	20.0	

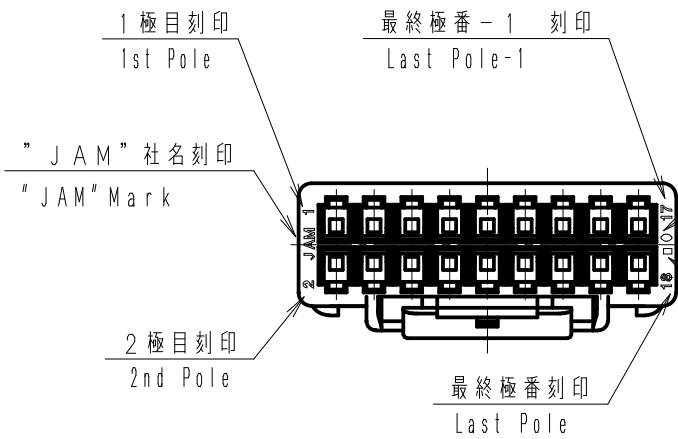

○は型No. 刻印 (a~)  
O, Model No. Mark (a~)

□はキャビNo. 刻印 (A~)  
□, Cav No. Mark (A~)

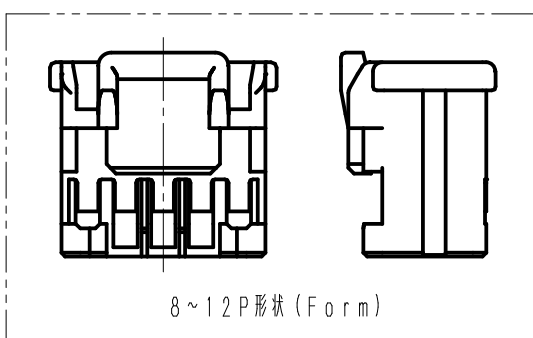
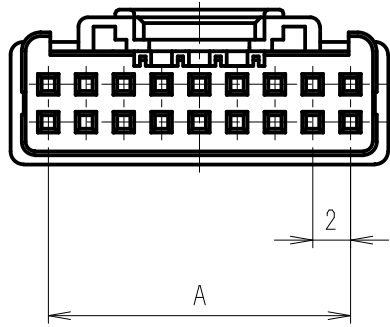
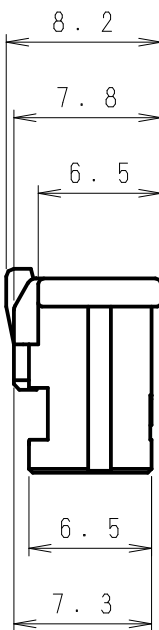
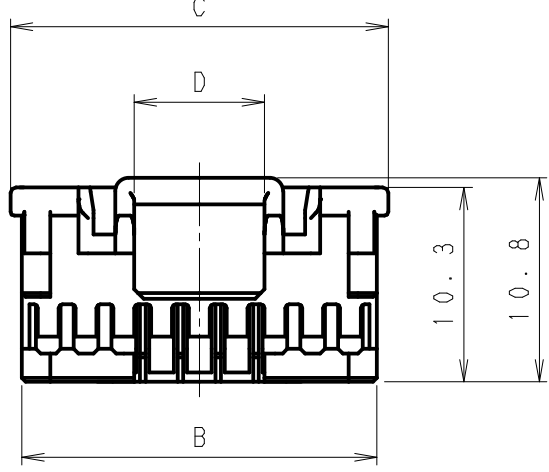

△5	. .							
△4	. .							
△3	. .				SJW2K-□□HG	ナイロン66 Nylon 66	UL94V-0	
△2	. .				製品番号 PRODUCT No.	材 料 MATERIAL	備考 NOTE	色 COLOR
△1	. .							
記号 No.	年月日 DATE	変更記事 REVISION RECORD	設計 DESIGN	承認 APP	製品名 NAME		SJW ハウジング SJW Housing	
承認 APPROVED	確認 CHECKED		一般公差 TOLERANCE		尺度 SCALE	図番 DRAWING No.		
K. Kusano	N. Nemoto		±0.3		2.5/1	JC-1072-05		
設計 DESIGN	製図 DRAWING		<b>JAPAN AUTOMATIC MACHINE CO., LTD.</b>					
K. Kusano	Y. Shimizu							

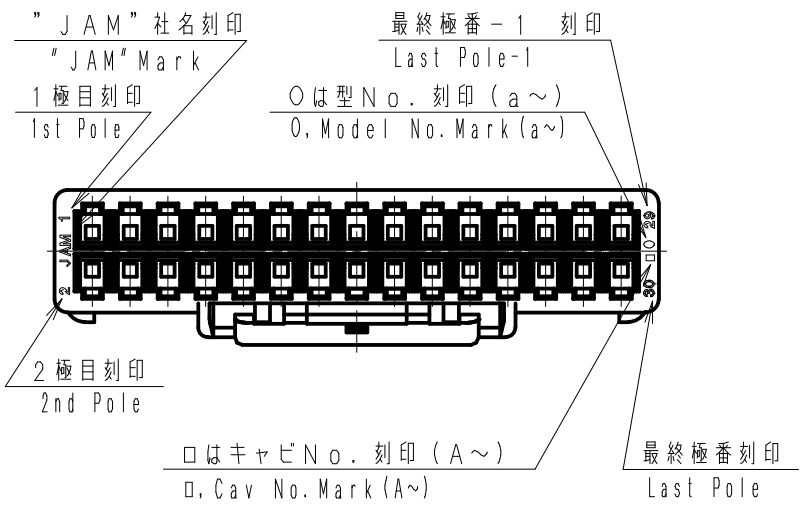

Poles	A	B	C
20	18.0	20.8	22.0
22	20.0	22.8	24.0
24	22.0	24.8	26.0
26	24.0	26.8	28.0
28	26.0	28.8	30.0
30	28.0	30.8	32.0
32	30.0	32.8	34.0
34	32.0	34.8	36.0
36	34.0	36.8	38.0
38	36.0	38.8	40.0
40	38.0	40.8	42.0

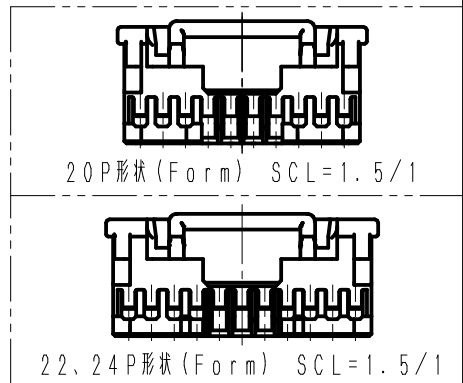
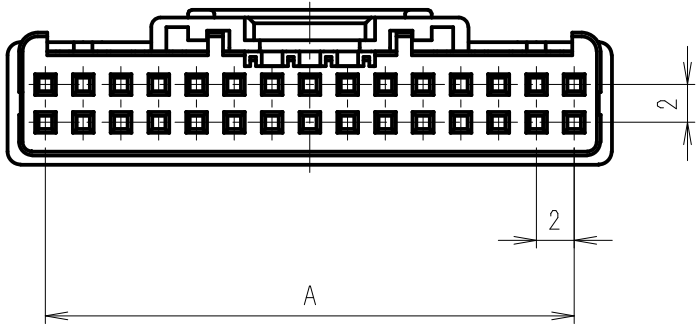
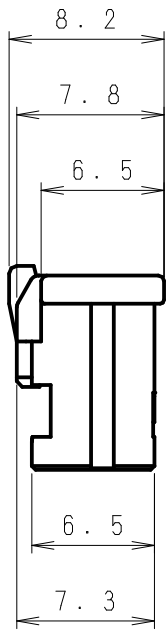
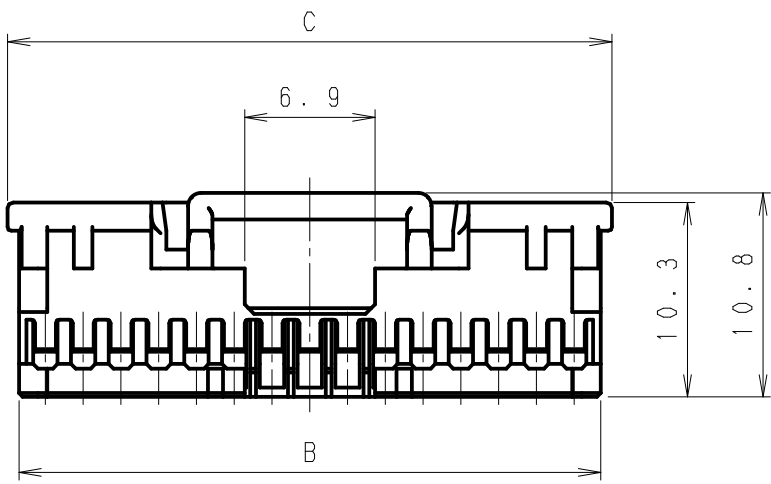



△5	. .							
△4	. .							
△3	. .				SJW2K-□□HG	ナイロン66 Nylon 66	UL94V-0	
△2	. .				製品番号 PRODUCT No.	材 料 MATERIAL	備考 NOTE	色 COLOR
△1	. .							
記号 No.	年月日 DATE	変更記事 REVISION RECORD	設計 DESIGN	承認 APP	製品名 NAME		SJW ハウジング SJW Housing	
承認 APPROVED	確認 CHECKED		一般公差 TOLERANCE		尺度 SCALE	図番 DRAWING No.		
K. Kusano	N. Nemoto		±0.3		2.5/1	JC-1072-06		
設計 DESIGN	製図 DRAWING		<b>JAPAN AUTOMATIC MACHINE CO., LTD.</b>					
K. Kusano	Y. Shimizu							

第三角法  
3rd ANGLE PROJECTION

単位: mm  
UNIT: mm  
注) . . . . . 図面を実測しないこと  
NOTES) . . . . . DO NOT SCALE

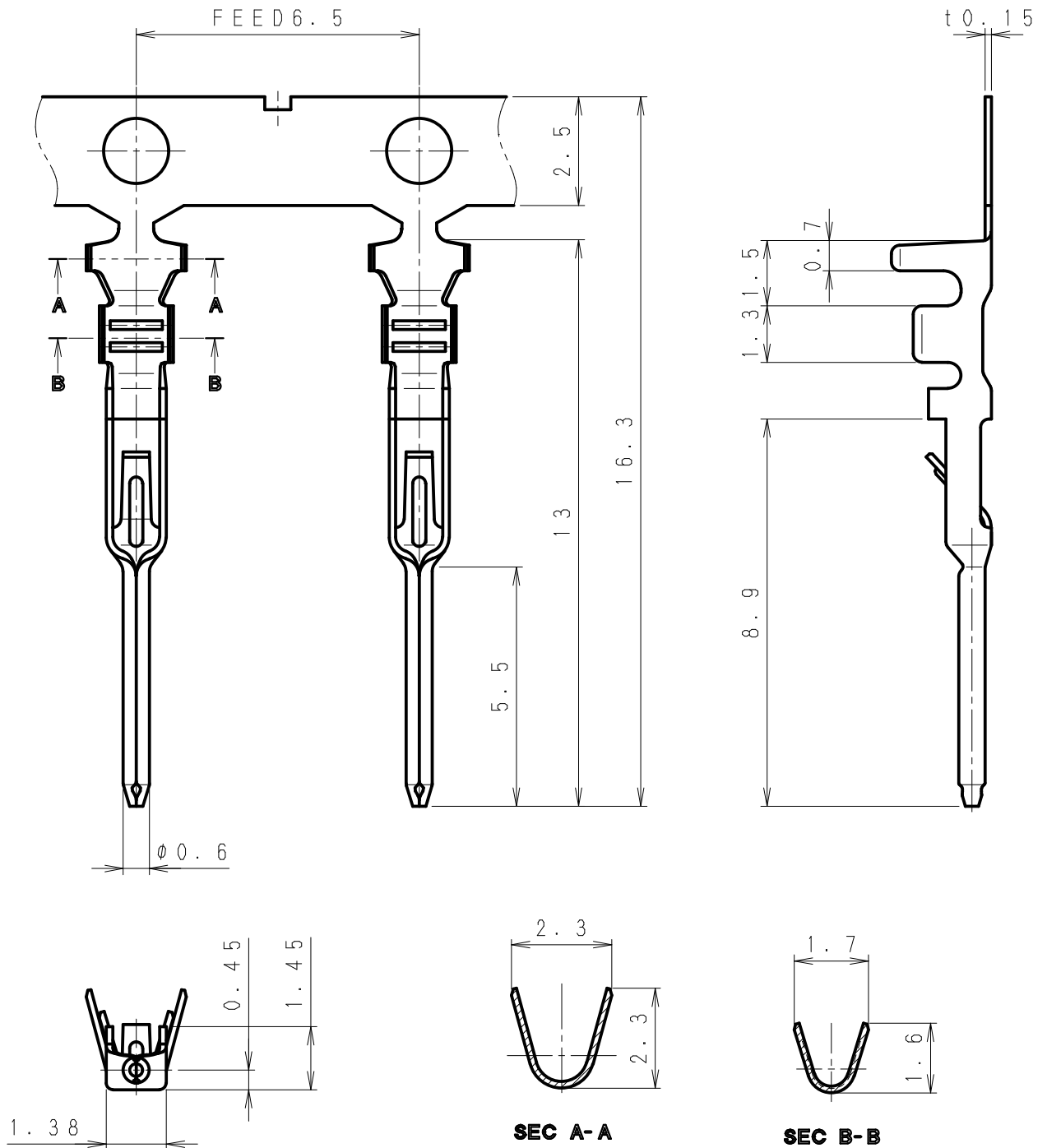
図番 DRAWING No.  
JC-0948-05



△6	. .								
△5	. .								
△4	. .				720467-2MAC	リン青銅 Phosphor Bronze	錫鍍金材 Pre-tin Plated	AWG#22~28	MAX φ1.5
△3	. .				製品番号 PRODUCT No.	材 料 MATERIAL	表面処理 FINISH	適用電線 WIRE SIZE	被覆外径 INSULATION DIA
△2	. .								
△1	. .								
記号 No.	年月日 DATE	変更記事 REVISION RECORD	設計 DESIGN	承認 APP	製品名 NAME		ターミナル Terminal		
承認 APPROVED	Y. Horiuchi	確認 CHECKED	Y. Horiuchi	一般公差 TOLERANCE	±0.3	尺度 SCALE	7 / 1	図番 DRAWING No.	JC-0948-05
設計 DESIGN	K. Kusano	製図 DRAWING	K. Kusano	 JAPAN AUTOMATIC MACHINE CO., LTD.					

第三角法  
3rd ANGLE PROJECTION

単位: mm 注) . . . . 図面を実測しないこと  
UNIT: mm NOTES) . . . . DO NOT SCALE

図番 DRAWING No.  
JC-0911-21

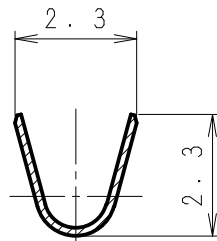
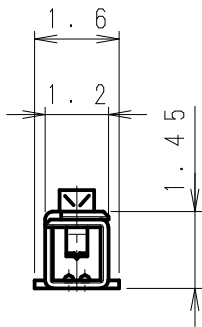
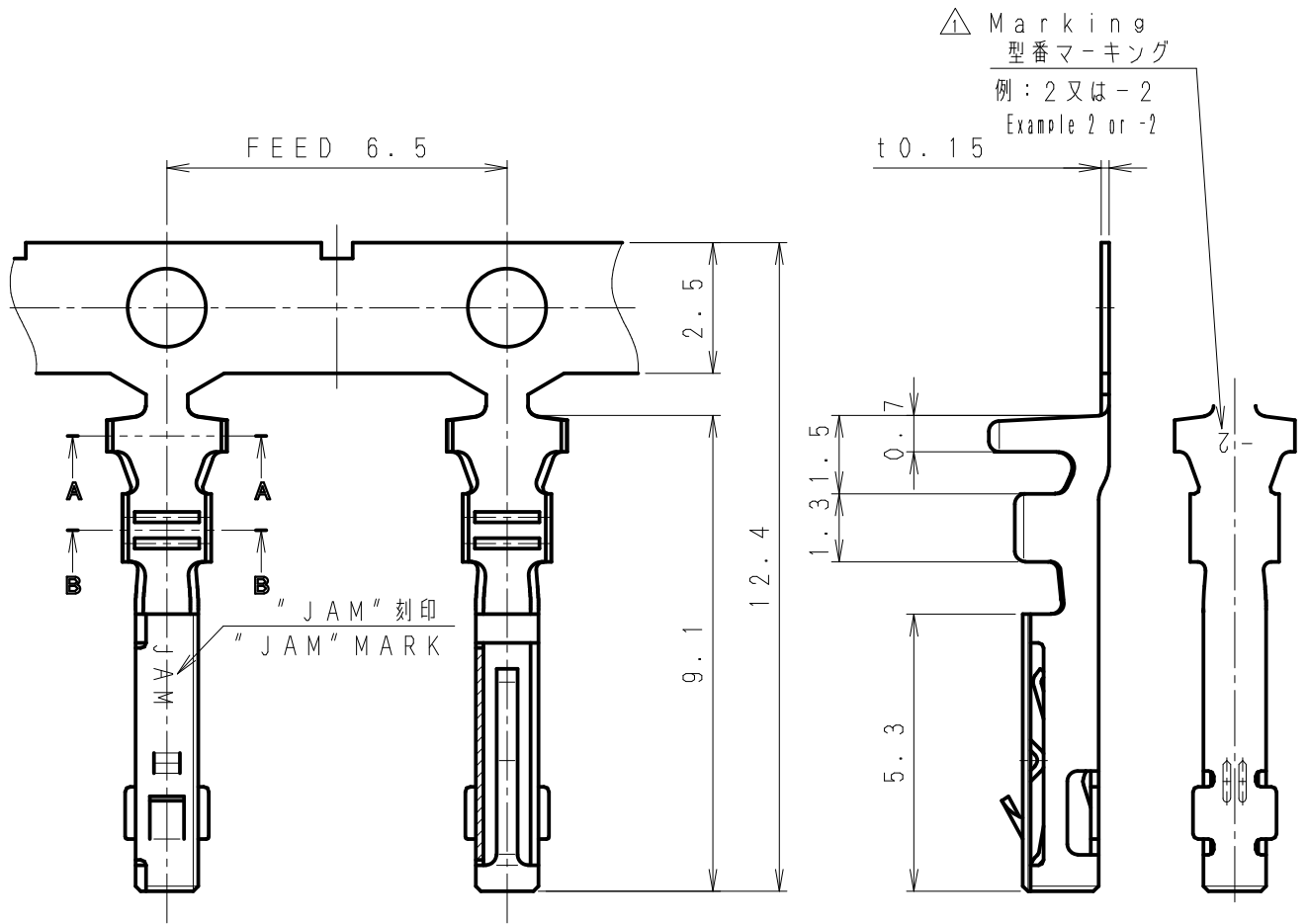

SEC A-A

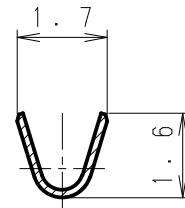

SEC B-B

△6	. .								
△5	. .								
△4	. .				720468-2MAC	リン青銅 Phosphor Bronze	錫鍍金材 Pre-tin Plated	AWG#22~28	MAX φ1.5
△3	. .				製品番号 PRODUCT No.	材 料 MATERIAL	表面処理 FINISH	適用電線 WIRE SIZE	被覆外径 INSULATION DIA
△2	. .								
△1	07.2.26	型番表記追加 Model mark addition	清水	堀内					
記号 No.	年月日 DATE	変更記事 REVISION RECORD	設計 DESIGN	承認 APP	製品名 NAME		ターミナル Terminal		
承認 APPROVED	確認 CHECKED		一般公差 TOLERANCE		尺度 SCALE	図番 DRAWING No.			
Y. Horiuchi	Y. Horiuchi		±0.3		6 / 1	JC-0911-21			
設計 DESIGN	製図 DRAWING		 JAPAN AUTOMATIC MACHINE CO., LTD.						
K. Kusano	K. Kusano								