

御中

製品仕様書
Product specifications

製品名 Product Name	SJHコネクタ SJH connector	
製品番号 Product Number	ターミナル Terminal	720374-2MAC 720474-2MAC
	ハウジング Housing	SJH2K-□□HG
	ウエハー Wafer	SJH2K-□□WS□B SJH2K-□□WLB

受領印欄

Acknowledged

日本オートマチックマシン株式会社
電子部品事業部 製品技術G
〒146-0092 東京都大田区下丸子3-28-4
TEL 03(3756)1435
JAPAN AUTOMATIC MACHINE CO., LTD
Product Engineering Group Electronic Parts
Headquarters
3-28-4, Shimomaruko, Ota-ku, Tokyo 146-0092, Japan

※ RoHS対応品
This product corresponds to RoHS.

<変更履歴表> ALTERATION HISTORY RECORDS

履歴 Revision	日付 Date	変更内容 Contents of Alteration	変 更 Change	承 認 Approved
制定 Issue	2010. 5. 6	—	—	—
改版 Revision	2016. 3. 29	書式変更 Format change.	大垣	草野
△	2019. 7. 18	手はんだ条件追記 Soldering iron condition add.	大垣	小泉
△				
△				
△				
△				
△				
△				
△				
△				

<目次> INDEX

1. 適用範囲 (Scope)
2. 製品名・製品番号 (Product name and number)
3. 形状・寸法・材料 (Geometry and materials)
4. 定格 (Rated values)
5. 性能 (Performances)
6. 梱包・表示 (Packing and marking)
7. 品番構成 (Product No. code)

仕 様 書 Specifications

SA-1380S12-Z11-3/15

1. 適用範囲 (Scope)

この製品仕様書は「S J Hコネクタ」の一般仕様及び性能について規定する。
The present document concerns general specifications and performances of "SJH connector".

2. 製品名・製品番号 (Product name and number)

製品名 Product Name	製品番号 Number	材料及び表面処理 Material and surface treatment
ターミナル Terminal	7 2 0 3 7 4 - 2 M A C	リン青銅 スズメッキ材 Phosphor bronze , Pre-tin Plated
	7 2 0 4 7 4 - 2 M A C	
ハウジング Housing	S J H 2 K - □ □ H G ※ ※	ナイロン 6 6 (UL94V-0) Nylon 66 (UL94V-0)
ウエハー (ボス付、ストレート型) Wafer, Straight type with boss	S J H 2 K - □ □ W S □ B ※ ※	ベース : ナイロン 6 6 (UL94V-0) 角ピン : 黄銅 (スズメッキ) ※ S J H 2 K - 0 2 W S K B ※ ※ は (スズ銅メッキ)
ウエハー (ボス付、アングル型) Wafer, Angle type with boss	S J H 2 K - □ □ W L B ※ ※	

3. 形状・寸法・材料 (Geometry and materials)

添付図面による。
Refer to attached drawings.

図面番号 Drawing No.	製品名 Product name	記号 Mark
J C - 1 0 7 9 - 0 1	S J H コネクタ (ボス付 ストレート型) SJH Connector, Straight type with boss	2P △
J C - 1 0 7 9 - 0 2	S J H コネクタ (ボス付 ストレート型) SJH Connector, Straight type with boss	2~3P △
J C - 1 0 7 9 - 0 3	S J H コネクタ (ボス付 ストレート型) SJH Connector, Straight type with boss	4P △
J C - 1 0 7 9 - 0 4	S J H コネクタ (ボス付 ストレート型) SJH Connector, Straight type with boss	5~7P △
J C - 1 0 7 9 - 0 5	S J H コネクタ (ボス付 ストレート型) SJH Connector, Straight type with boss	8~16P △
J C - 1 0 7 9 - 0 6	S J H コネクタ (ボス付 アングル型) SJH Connector, Angle type with boss	2~3P 0
J C - 1 0 7 9 - 0 7	S J H コネクタ (ボス付 アングル型) SJH Connector, Angle type with boss	4P 0
J C - 1 0 7 9 - 0 8	S J H コネクタ (ボス付 アングル型) SJH Connector, Angle type with boss	5~7P 0
J C - 1 0 7 9 - 0 9	S J H コネクタ (ボス付 アングル型) SJH Connector, Angle type with boss	8~16P 0

仕 様 書 Specifications

SA-1380S12-Z11-4/15

図面番号 Drawing No.	製品名 Product name	記号 Mark
J C - 0 9 5 0 - 0 9 Z	S J Hハウジング SJH housing 2~3P	0
J C - 0 9 5 0 - 1 0 Z	S J Hハウジング SJH housing 4P	0
J C - 0 9 5 0 - 1 1 Z	S J Hハウジング SJH housing 5~7P	0
J C - 0 9 5 0 - 1 2 Z	S J Hハウジング SJH housing 8~16P	0
J C - 1 0 7 9 - 1 0	S J Hウエハー (ボス付 ストレート型) SJH Wafer, Straight type with boss 2P	△
J C - 1 0 7 9 - 1 9	S J Hウエハー (ボス付 ストレート型) SJH Wafer, Straight type with boss 2P	0
J C - 1 0 7 9 - 1 1	S J Hウエハー (ボス付 ストレート型) SJH Wafer, Straight type with boss 3P	△
J C - 1 0 7 9 - 1 2	S J Hウエハー (ボス付 ストレート型) SJH Wafer, Straight type with boss 4~7P	△
J C - 1 0 7 9 - 1 3	S J Hウエハー (ボス付 ストレート型) SJH Wafer, Straight type with boss 8~16P	△
J C - 1 0 7 9 - 1 4	S J Hウエハー (ボス付 アングル型) SJH Wafer, Angle type with boss 2P	0
J C - 1 0 7 9 - 1 5	S J Hウエハー (ボス付 アングル型) SJH Wafer, Angle type with boss 3P	0
J C - 1 0 7 9 - 1 6	S J Hウエハー (ボス付 アングル型) SJH Wafer, Angle type with boss 4~7P	0
J C - 1 0 7 9 - 1 7	S J Hウエハー (ボス付 アングル型) SJH Wafer, Angle type with boss 8~16P	0
J C - 0 8 1 0 - 1 4 Z	ターミナル Terminal	△
J C - 0 8 1 0 - 1 5 Z	ターミナル Terminal	△
J C - 1 0 7 9 - 1 8	S J Hウエハー基板レイアウト (ボス) SJH Wafer P.C.B. Layout (With boss)	△

4. 定格 (Rated values)

項目 Item	規格値 Description	
定格電圧 Rated voltage	250V AC, DC 250 V AC, DC	
定格電流 Rated current	3A (注1) 3 A (Note 1)	
使用温度範囲 Temperature range	-40 ~ +85°C (通電による温度上昇分を含む) -40 to +85°C (heating by energization included)	
適用電線範囲 (注2) Wire size (Note 2)	720474	AWG #22 ~ #24 被覆外径 ϕ 1.1 ~ 1.6 mm AWG #22 to #24 Diameter of insulation covering ϕ 1.1 to ϕ 1.6 mm
	720374	AWG #24 ~ #30 被覆外径 ϕ 0.8 ~ 1.5 mm AWG #24 to #30 Diameter of insulation covering ϕ 0.8 to ϕ 1.5 mm
適用プリント基板 Applicable P.C. board	厚さ Thickness	0.8 ~ 1.6 mm
	穴径 Hole diameter	SJH2K-02WSKB ϕ 0.75 ^{+0.05} ₋₀ SJH2K-□□WSB/SJH2K-□□WLB ϕ 0.8 ± 0.05
保存温度 Storage temperature	-30 ~ +60°C (90%RH以下) -30 to +60°C (90% RH or less)	

(注1) 定格電流はターミナル接触部の定格値であり、実使用においては使用電線の定格電流、使用温度により決定される。

(Note 1) The rated current shown is at the terminal contact section. Practically, it varies depending on rated current of particular wire and operating temperature.

(注2) 電線はより線を使用し、単線等の特殊電線は原則として使用出来ません。

(Note 2) Use a stranded wire. Do not use solid or other special wires.

5. 性能 (Performances)

性能は、下表に示す試験条件及び方法で試験を実施したとき、各項目に規定する規格値を満足すること。尚、試験は特に指定のない限り JIS C 60068-1 [環境試験方法 (電気、電子)通則] に規定された試験場所の標準にて実施する。

The performances tested under the conditions and methods given in the table below shall conform to the respective specifications. Unless otherwise specified, carry out the tests according to the standards of a place of test stipulated in JIS C 60068-1 "General Rules of Environmental Testing Method (Electric and Electronic)".

5-1 外観 (Appearance)

No.	項目 Item	規格値 Description	条件 Check
5-1-1	外観 Appearance	使用上有害となる様な割れ・変形等が無いこと Crack, deformation, etc. harmful in use are not allowed	目視 Visual

5-2 機械的性能 (Mechanical properties)

No.	項目 Item	規格値 Description	試験条件及び方法 Check	
5-2-1	挿入力 Insertion force	別表A参照 See Appended Table A	ウエハーへのハウジング挿入力を、測定する。 試験速度 25mm/min Measure the force required for inserting the wafer into housing at 25mm/min.	
5-2-2	保持力 Pull-out force	別表A参照 See Appended Table A	ハウジングロックを除去してウエハーとの保持力を測定する。 試験速度 25mm/min Unlock the housing, and measure the pull-out force of wafer at 25mm/min	
5-2-3	ハウジングロック 保持力 Housing locking power	29.4 N以上 29.4 N or more	ウエハーとハウジングを嵌合させ、ハウジングを引張り、ロックが外れるときの力を測定する。 試験速度 25mm/min Engage the wafer and housing with each other, and pull the housing at 25 mm/min until unlocked. Take the reading at this point.	
5-2-4	圧着部引張強度 Tensile strength of crimped section	電線 Wire size	強度 N 以上 Minimum strength in N	ターミナルのワイヤバレルと電線導体を圧着し、治具で固定し電線の軸方向に引っ張る。 試験速度 25mm/min Crimp the terminal's wire barrel and conductor together, fasten the altogether, and pull the wire axially at 25 mm/min.
		AWG#22	44.1	
		AWG#24	29.4	
		AWG#26	19.6	
		AWG#28	9.8	
AWG#30	4.9			
5-2-5	ターミナル 挿入力 Terminal insertion force	6.9 N 以下 6.9 N or less	ターミナルをハウジングに挿入するのに要する力を万能試験機を用いて測定する。 試験速度 25mm/min Using universal testing machine, measure the force required for inserting the terminal into housing at 25 mm/min.	

No.	項目 Item	規格値 Description	試験条件及び方法 Check
5-2-6	ターミナル 保持力 Terminal pull-out force	9.8 N 以上 9.8 N or more	ハウジングに装着したターミナルを軸 方向に引張り、ハウジングからターミ ナルが離脱するときの荷重を万能試験 機を用いて測定する。 試験速度 25mm/min Using universal testing machine, pull the terminal axially at 25 mm/min until it leaves the housing. Take the reading at this point.
5-3-7	ウエハー 角ピン保持力 Wafer pin withdrawal force	9.8 N 以上 9.8 N or more	半田付け後、ウエハーの角ピンを基板 装着方向に押し出す。 Push wafer pin toward the direction of P.C. board attachment after soldering.

5-3 電气的性能 (Electrical characteristics)

No.	項目 Item	規格値 Description	試験条件及び方法 Check
5-3-1	接触抵抗 Contact resistance	初期 10 mΩ 以下 10 mΩ or less initially	コネクタを嵌合状態にして電気抵抗を測定し、電線抵抗を差し引いて接触抵抗とする。 試験電流 15mA (20mV以下) Engage the connector, measure the overall resistance at 15 mA and 20 mV or less and, from the reading, subtract the wire resistance. Retain the difference as contact resistance.
5-3-2	絶縁抵抗 Insulation resistance	1000 MΩ 以上 1000 MΩ or more	コネクタ外面とターミナル相互間及び隣接するターミナル間にDC500Vを印可して測定する。 Apply 500 V DC between connector housing and each of terminals, and between adjacent terminals.
5-3-3	耐電圧 Dielectric strength	AC 1000V / 1分間 異常なきこと AC 1000V / 1min. Shall remain normal	ハウジング外面とターミナル相互間及び隣接するターミナル間にて測定する。 Apply 1000 V AC for 1 min between connector housing and each of terminals, and between adjacent terminals.
5-3-4	温度上昇 Temperature rise	30 K 以下 (適用最大電線による) 30 K or less (With thickest applicable wire)	ハウジングの全極にターミナルを装着し、嵌合させて各ターミナルを直列に接続し、最大定格電流を通電した時のターミナル部の温度上昇を測定する。 Mount the terminals on all housing poles, engage them, connect all terminals in series, apply rated current, and measure the temperature at terminals.

5-4 耐久環境性能 (Durability)

No.	項目 Item	規格値 Description		試験条件及び方法 Check
5-4-1	挿抜寿命 Engagement and disengagement	接触抵抗 Contact resistance	20mΩ 以下 20 mΩ or less	ハウジングにターミナルを装着し、ウエハーにハウジングを挿抜(30回)試験前後の接触抵抗を測定する。 Mount the terminals on housing, repeat 30 cycles of insertion and removal of housing into and from wafer, and measure the contact resistance.
		外観 Appearance	異常なきこと Shall remain normal	
5-4-2	耐振動性 Vibration	接触抵抗 Contact resistance	20mΩ 以下 20 mΩ or less	コネクタを結合し、下記条件にて振動試験実施。 掃引割合 10~55~10Hz 掃引時間 1分 最大振幅 1.5 mm 振動軸方向 X、Y、Z 振動時間 各2時間=6時間 Engage the connector, and carry out tests under following conditions. Sweep frequency 10-55-10 Hz. Sweep time 1 min. Maximum amplitude 1.5 mm. Vibration axes X, Y, Z. Vibration time 2 h each or totally 6 h.
		電流瞬断 Momentary failure	1μs 以下 1 μ sec or less	
		外観 Appearance	異常なきこと Shall remain normal	
5-4-3	耐熱性 Heating	接触抵抗 Contact resistance	20mΩ 以下 20 mΩ or less	コネクタを結合後、下記条件に放置 雰囲気温度 100±5℃ 放置時間 240時間 室内で1~2時間放置後測定 Engage the connector, and keep the sample for 240 h under following conditions. Ambient temperature 100 ± 5°C. Leave the sample at the room for 1 to 2 h before check.
		外観 Appearance	異常なきこと Shall remain normal	

No.	項目 Item	規格値 Description		試験条件及び方法 Check
5-4-4	耐寒性 Cold	接触抵抗 Contact resistance	20mΩ 以下 20 mΩ or less	コネクタを結合後、下記条件に放置 雰囲気温度 $-40 \pm 3^{\circ}\text{C}$ 放置時間 240時間 室内で1～2時間放置後測定 Engage the connector, and keep the sample for 240 h under following conditions. Ambient temperature $-40 \pm 3^{\circ}\text{C}$. Leave the sample at the room for 1 to 2 h before check.
		外観 Appearance	異常なきこと Shall remain normal	
5-4-5	耐熱衝撃性 Heat shock	接触抵抗 Contact resistance	20mΩ 以下 20 mΩ or less	コネクタを結合後、下記条件に放置 1. 低温側 $-40 \pm 2^{\circ}\text{C}$ 30分 2. 室温 $+25 \pm 10^{\circ}\text{C}$ 10～15分 3. 高温側 $+85 \pm 2^{\circ}\text{C}$ 30分 4. 室温 $+25 \pm 10^{\circ}\text{C}$ 10～15分 1～4を25サイクル行う。 Engage the connector, and subject it to 25 cycles of following sequence. 1. Low temperature $-40 \pm 2^{\circ}\text{C}$ for 30 min. 2. Room temperature $+25 \pm 10^{\circ}\text{C}$ within 10 to 15 min. 3. High temperature $+85 \pm 2^{\circ}\text{C}$ for 30 min. 4. Room temperature $+25 \pm 10^{\circ}\text{C}$ within 10 to 15 min.
		外観 Appearance	異常なきこと Shall remain normal	

No.	項目 Item	規格値 Description		試験条件及び方法 Check
5-4-6	耐湿性 Moisture	接触抵抗 Contact resistance	20mΩ 以下 20 mΩ or less	コネクタを結合後、下記条件に放置 雰囲気温度 60 ± 2℃ 相 対 湿 度 90 ~ 95% RH 放 置 時 間 240時間 室内で1 ~ 2時間放置後測定 Engage the connector, and keep the sample for 240 h under following conditions. Ambient temperature 60 ± 2°C. Relative humidity 90 to 95%. Leave the sample at the room for 1 to 2 h before check.
		絶縁抵抗 Insulation resistance	500MΩ 以上 500 MΩ or more	
		耐電圧 Dielectric strength	AC500V / 1分間 異常なきこと Shall remain normal at 500 V AC for 1 min	
		外観 Appearance	異常なきこと Shall remain normal	
5-4-7	耐アンモニア性 Ammonia	接触抵抗 Contact resistance	20mΩ 以下 20 mΩ or less	コネクタを結合後、下記アンモニア水の入ったデシケータ容器中に放置 濃 度 28% 温 度 25℃ 容 積 比 25ml / ℓ 放置時間 40分 室内で1 ~ 2時間放置後測定。 Engage the connector, and keep it in desiccator filled with following aqueous ammonia for 40 min. Concentration 28%. Temperature 25°C. Volume ratio 25 ml / ℓ Leave the sample at the room for 1 to 2 h before check.
		外観 Appearance	ターミナル各部に割れ・ヒビの発生なきこと Terminals shall remain free from scores and cracks	

No.	項目 Item	規格値 Description		試験条件及び方法 Check
5-4-8	耐塩水噴霧性 Salt mist	接触抵抗 Contact resistance	20mΩ 以下 20 mΩ or less	コネクタを結合後、下記条件に放置 温 度 35 ± 2℃ 塩水濃度 5 ± 1% (重量比) 噴霧時間 48時間 接触抵抗測定は、水洗をし室温で乾燥 させてから、1～2時間放置後測定。 Engage the connector, and keep the sample under following conditions. Temperature 35 ± 2°C. Salt concentration 5 ± 1%wt. Spray time 48 h. Then, rinse the sample, and leave it dry at room temperature for 1 to 2 h.
		外観 Appearance	異常なきこと Shall remain normal	
5-4-9	耐硫化水素 ガス性 Hydrogen sulfide	接触抵抗 Contact resistance	20mΩ 以下 20 mΩ or less	コネクタを結合後、下記硫化水素ガス 中に放置。 濃 度 3 ± 1 ppm 温 度 40 ± 2℃ 放置時間 96時間 室内で1～2時間放置後測定。 Engage the connector, and keep it in hydrogen sulfide for 96 h. Density 3 ± 1 ppm. Temperature 40 ± 2°C. Leave the sample at the room for 1 to 2 h before check.
		外観 Appearance	異常なきこと Shall remain normal	

5-5 半田付性能 (Soldering characteristics)

No.	項目 Item	規格値 Description	試験条件及び方法 Check
5-5-1	はんだ付性 Solderability	半田面に半田がムラ無く 全体に付くこと 浸漬面積の95%以上 95% or more of dipped solder side shall be coated uniformly with solder	ウエハーの角ピンはんだ付部をフラックスに5～10秒浸漬後、下記条件のはんだ槽に浸漬する。 はんだ槽温度 245 ± 5℃ 浸漬時間 3 ± 0.5秒 Dip the square pin soldering section of wafer into flux for 5 to 10 sec, and then into solder tank of 245 ± 5℃ for 3 ± 0.5 sec.
5-5-2	はんだ耐熱性 Soldering heat	機能を損なう変形・損傷等のないこと Shall remain free from deformation, damage, etc. adversely affecting the functions	下記はんだ槽にウエハー角ピンはんだ付部を浸漬する。 はんだ槽温度 260 ± 5℃ 浸漬時間 5 ± 0.5秒 Dip the square pin soldering section into solder tank of 260 ± 5℃ for 5 ± 0.5 sec. △ 半田こて (Soldering iron) こて先温度(Temp.) 350 ± 10℃ 半田付時間(Time) 3 ± 0.5秒(s)

6. 梱包・表示 (Packing and marking)

6-1 ターミナル (Terminals)

ターミナルはリールに巻き、さらにダンボール箱に梱包して出荷。
表示はリールに型番、数量、ロットNo.を明記したラベルを貼り付ける。

Wind the terminals on reel, and pack it in cardboard case for shipment.
As indications, attach a label filled with product number, quantity and lot No. onto reel.

6-2ハウジング (Housings)

ナイロン袋に入れ、さらに、ダンボール箱に梱包して出荷。
表示はナイロン袋、ダンボール箱に型番、数量、ロットNo.を明記したラベルを貼り付ける。

Put the housings in nylon bag, and pack it in cardboard case for shipment.
As indications, attach labels filled with product number, quantity and lot No. onto nylon bag and cardboard case.

6-3 ウエハー (wafers)

ナイロン袋に入れ、さらに、ダンボール箱に梱包して出荷。
表示はナイロン袋、ダンボール箱に型番、数量、ロットNo.を明記したラベルを貼り付ける。

Put the wafers in nylon bag, and pack it in cardboard case for shipment.
As indications, attach labels filled with product number, quantity and lot No. onto nylon bag and cardboard case.

7. 品番構成 (Product No. code)

7-1 ターミナル (Terminal)

7 2 0 □ 7 4 - 2 M A C

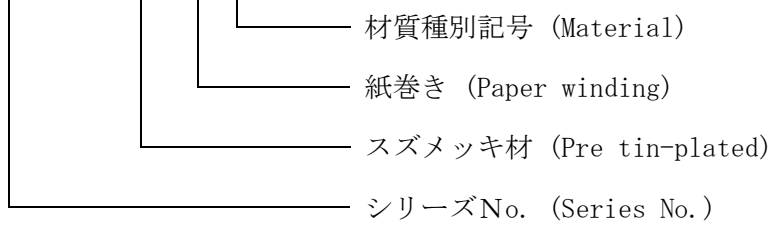

7-2 ハウジング・ウエハー (Housing·Wafer)

S J H 2 K - □ □ ○ ○ ○ ○ ※ ※

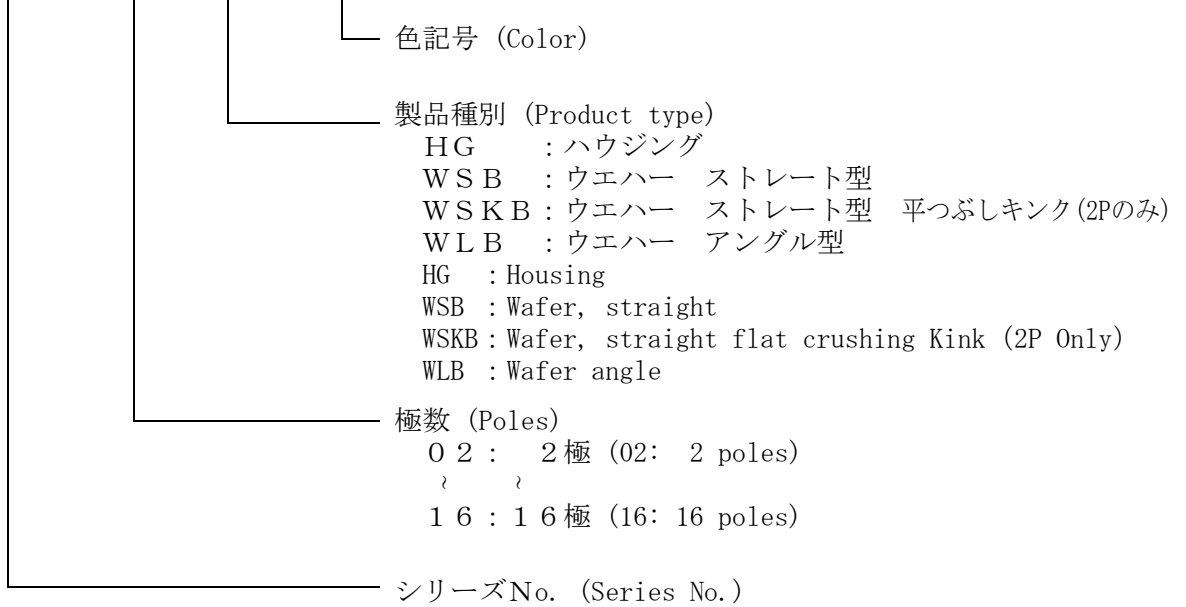

<色記号> <Color>

記号 Symbol	無 None	RE	PK	BR	GY	YG
色 Name	白 White	赤 Red	桃 Pink	紫 Purple	灰 Gray	若草 Yellowish green

記号 Symbol	YL	OR	BW	BL	GR	BK
色 Name	黄 Yellow	橙 Orange	茶 Brown	青 Blue	緑 Green	黒 Black

記号 Symbol	LY	LP	LO
色 Name	蛍光黄 Fluorescence yellow	蛍光桃 Fluorescence pink	蛍光橙 Fluorescence orange

※ JAMでの標準色は白色です。

The standard color in JAM is white.

【表A】挿入力及び引抜力

(Table A: Insertion force and pull-out force)

	挿入力(N以下) Maximum insertion force in N	保持力(N以上) Minimum pull-out force in N
2P	14.7	2.35
3P	19.6	3.53
4P	24.5	4.70
5P	29.4	5.88
6P	34.3	7.06
7P	39.2	8.23
8P	44.1	9.41
9P	49.0	10.58
10P	53.9	11.76
11P	58.8	12.94
12P	63.7	14.11
13P	68.6	15.29
14P	73.5	16.46
15P	78.4	17.64
16P	83.3	18.82

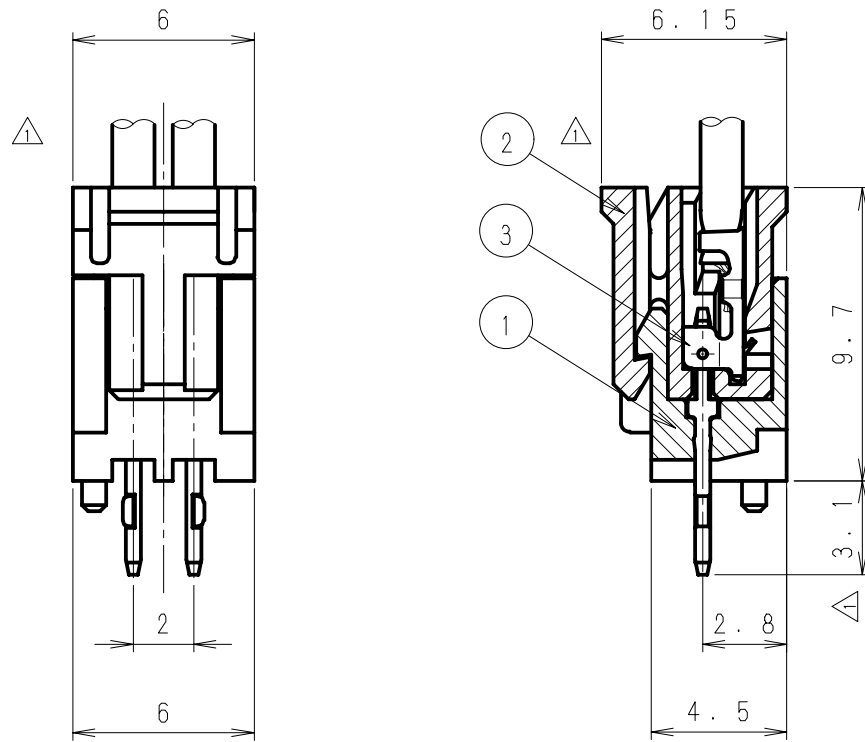

No.	製品番号 PRODUCT NO.	製品名 PRODUCT NAME	材質 MATERIAL
①	SJH2K-02WSKB	ウエハー Wafer	ナイロン66 (UL94V-0) Nylon66 (UL94V-0) 黄銅 (スズ銅メッキ) Brass (Sn-Cu Plating)
②	SJH2K-02HG	ハウジング Housing	ナイロン66 (UL94V-0) Nylon66 (UL94V-0)
③	720374-2MAC 720474-2MAC	ターミナル Terminal	リン青銅 (スズメッキ材) Phosphor bronze (Pre-tin Plated)

極数 Poles	2	
適用電線 Wire Size	720474	AWG#22~#24
	720374	AWG#24~#30
被覆外径 Insulation Dia.	720474	φ1.1~φ1.6mm
	720374	φ0.8~φ1.5mm

△	. . .							
△	. . .			製品番号 PRODUCT No.	No.	材 料 MATERIAL	備考 NOTE	色 COLOR
△	10. 5. 24	形状変更 Form change.	熊倉 草野					
記号 No.	年月日 DATE	変更記事 REVISION RECORD	設計承認 DESIGN APP	製品名 NAME			SJHコネクタ (ボス付 ストレート型) SJH Connector, Straight type with boss	
承認 APPROVED	確認 CHECKED		一般公差 TOLERANCE	尺度 SCALE	図番 DRAWING No.			
K. Kusano	K. Koizumi		±0.3	4/1	JC-1079-01			
設計 DESIGN	製図 DRAWING							
A. Kumakura	T. Murakami							

	Poles	A	B	C
△	2	6.0	6.0	2.0
	3	8.0	8.0	4.0

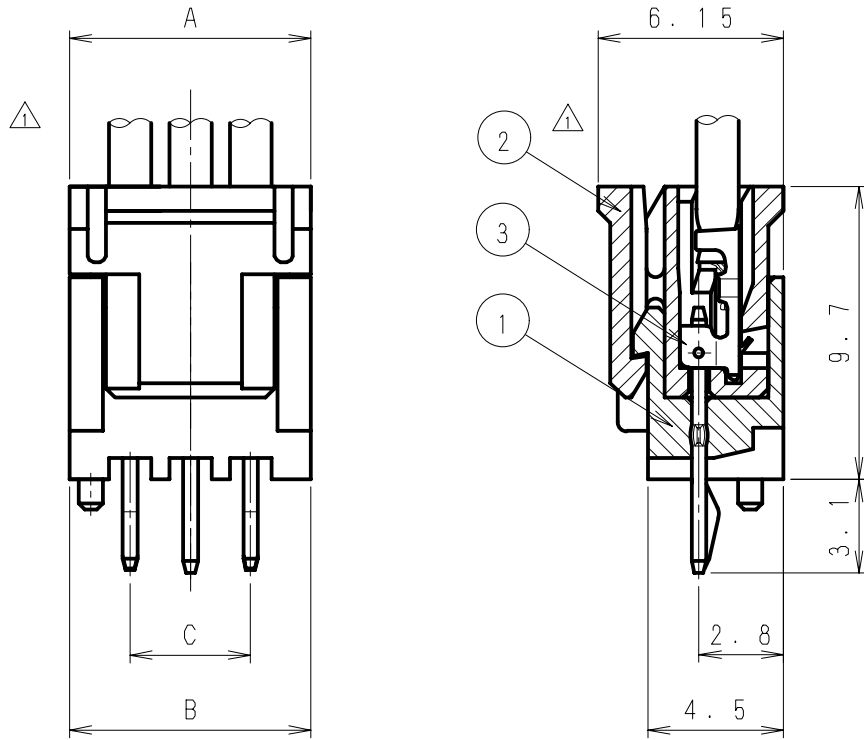

No.	製品番号 PRODUCT NO.	製品名 PRODUCT NAME	材質 MATERIAL
①	△ SJH2K-□WSB	ウエハー Wafer	ナイロン66 (UL94V-0) Nylon66 (UL94V-0) 黄銅 (スズメッキ) Brass (Tin Plating)
②	△ SJH2K-□DHG	ハウジング Housing	ナイロン66 (UL94V-0) Nylon66 (UL94V-0)
③	720374-2MAC 720474-2MAC	ターミナル Terminal	リン青銅 (スズメッキ材) Phosphor bronze (Pre-tin Plated)

極数 Poles	△ 2~3	
適用電線 Wire Size	720474	AWG#22~#24
	720374	AWG#24~#30
被覆外径 Insulation Dia.	720474	φ1.1~φ1.6mm
	720374	φ0.8~φ1.5mm

△	. .				製品番号 PRODUCT No.	No.	材 料 MATERIAL	備考 NOTE	色 COLOR
△	10. 5. 24	形状変更、アイテム追加 Form change, Item add.	熊倉	草野					
記号 No.	年月日 DATE	変更記事 REVISION RECORD	設計 DESIGN	承認 APP	製品名 SJHコネクタ (ボス付 ストレート型) NAME SJH Connector, Straight type with boss				
承認 APPROVED	確認 CHECKED		一般公差 TOLERANCE		尺度 SCALE	図番 DRAWING No.			
K. kusano	K. Koizumi		±0.3		4 / 1	JC-1079-02			
設計 DESIGN	製図 DRAWING		JAPAN AUTOMATIC MACHINE CO., LTD.						
A. Kumakura	T. Murakami								

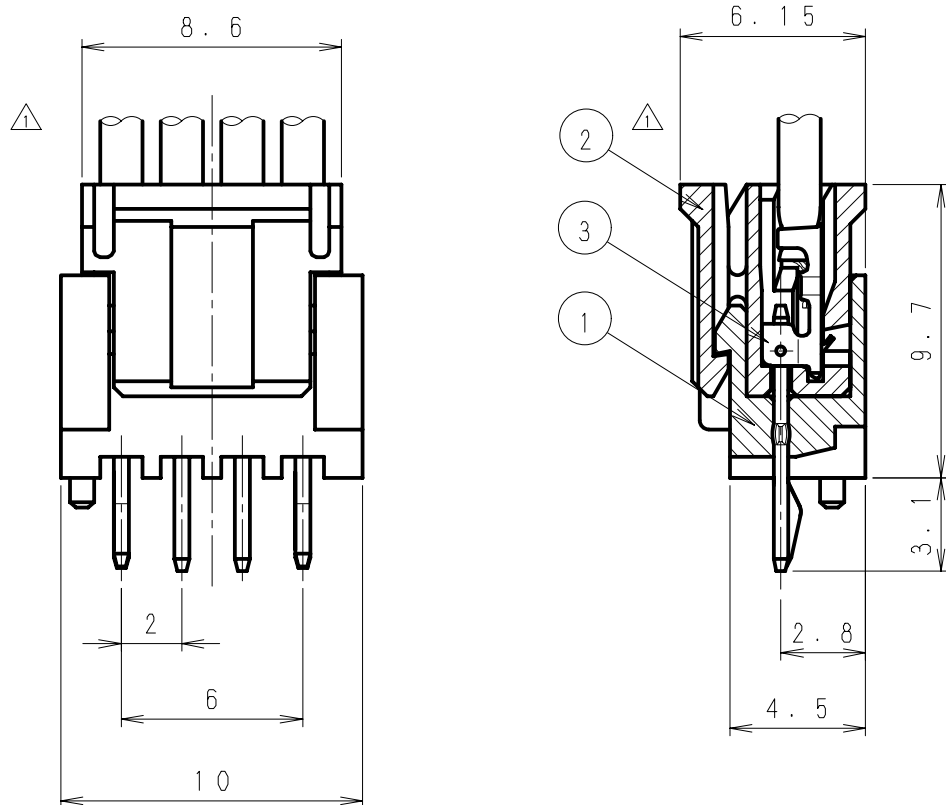

No.	製品番号 PRODUCT NO.	製品名 PRODUCT NAME	材質 MATERIAL
①	SJH2K-04WSB	ウエハー Wafer	ナイロン66 (UL94V-0) Nylon66 (UL94V-0) 黄銅 (スズメッキ) Brass (Tin Plating)
②	SJH2K-04HG	ハウジング Housing	ナイロン66 (UL94V-0) Nylon66 (UL94V-0)
③	720374-2MAC 720474-2MAC	ターミナル Terminal	リン青銅 (スズメッキ材) Phosphor bronze (Pre-tin Plated)

極数 Poles	4	
適用電線 Wire Size	720474	AWG#22~#24
	720374	AWG#24~#30
被覆外径 Insulation Dia.	720474	φ1.1~φ1.6mm
	720374	φ0.8~φ1.5mm

△3	. .							
△2	. .			製品番号 PRODUCT No.	No.	材 料 MATERIAL	備考 NOTE	色 COLOR
△1	10. 5. 24	形状変更 Form change.	熊倉 草野					
記号 No.	年月日 DATE	変更記事 REVISION RECORD	設計承認 DESIGN APP	製品名 NAME			SJHコネクタ (ボス付 ストレート型) SJH Connector, straight type with boss	
承認 APPROVED	K. Kusano	確認 CHECKED	K. Koizumi	一般公差 TOLERANCE	±0.3	尺度 SCALE	4 / 1	図番 DRAWING No.
設計 DESIGN	A. Kumakura	製図 DRAWING	T. Murakami	JAPAN AUTOMATIC MACHINE CO., LTD.				

Poles	A	B	C
5	10.6	12.0	8.0
6	12.6	14.0	10.0
7	14.6	16.0	12.0

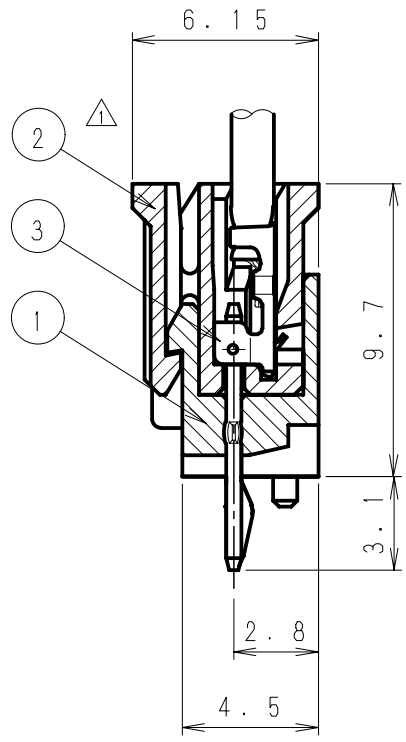
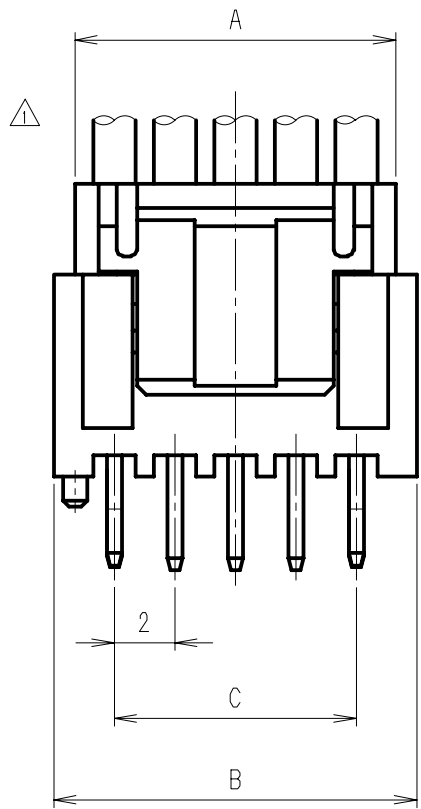

No.	製品番号 PRODUCT NO.	製品名 PRODUCT NAME	材質 MATERIAL
①	SJH2K-□WSB	ウエハー Wafer	ナイロン66 (UL94V-0) Nylon66 (UL94V-0) 黄銅 (スズメッキ) Brass (Tin Plating)
②	SJH2K-□DHG	ハウジング Housing	ナイロン66 (UL94V-0) Nylon66 (UL94V-0)
③	720374-2MAC	ターミナル Terminal	リン青銅 (スズメッキ材) Phosphor bronze (Pre-tin Plated)
	720474-2MAC		

極数 Poles	5~7	
適用電線 Wire Size	720474	AWG#22~#24
	720374	AWG#24~#30
被覆外径 Insulation Dia.	720474	φ1.1~φ1.6mm
	720374	φ0.8~φ1.5mm

△3	. .								
△2	. .			製品番号 PRODUCT No.	No.	材 料 MATERIAL	備考 NOTE	色 COLOR	
△1	10. 5. 24	形状変更 Form change.	熊倉 草野						
記号 No.	年月日 DATE	変更記事 REVISION RECORD	設計承認 DESIGN APP	製品名 NAME			SJHコネクタ (ボス付 ストレート型) SJH Connector, Straight type with boss		
承認 APPROVED	確認 CHECKED		一般公差 TOLERANCE	尺度 SCALE	図番 DRAWING No.				
K. Kusano	K. Koizumi		±0.3	4/1	JC-1079-04				
設計 DESIGN	製図 DRAWING								
A. Kumakura	T. Murakami								

Poles	A	B	C	Poles	A	B	C
8	16.6	18.0	14.0	13	26.6	28.0	24.0
9	18.6	20.0	16.0	14	28.6	30.0	26.0
10	20.6	22.0	18.0	15	30.6	32.0	28.0
11	22.6	24.0	20.0	16	32.6	34.0	30.0
12	24.6	26.0	22.0	—	—	—	—

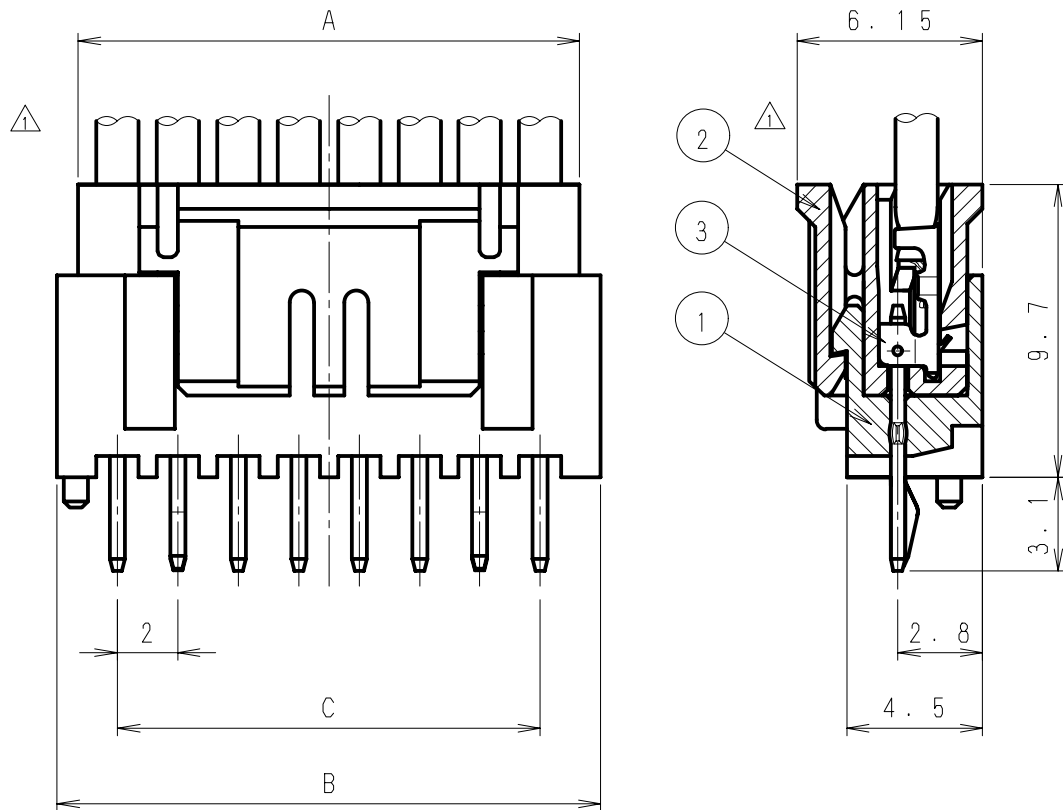

No.	製品番号 PRODUCT NO.	製品名 PRODUCT NAME	材質 MATERIAL
①	SJH2K-□WSB	ウエハー Wafer	ナイロン66 (UL94V-0) Nylon66 (UL94V-0) 黄銅 (スズメッキ) Brass (Tin Plating)
②	SJH2K-□DHG	ハウジング Housing	ナイロン66 (UL94V-0) Nylon66 (UL94V-0)
③	720374-2MAC 720474-2MAC	ターミナル Terminal	リン青銅 (スズメッキ材) Phosphor bronze (Pre-tin Plated)

極数 Poles	8 ~ 16	
適用電線 Wire Size	720474	AWG#22~#24
	720374	AWG#24~#30
被覆外径 Insulation Dia.	720474	φ1.1~φ1.6mm
	720374	φ0.8~φ1.5mm

△3	. .													
△2	. .				製品番号 PRODUCT No.	No.	材 料 MATERIAL	備考 NOTE	色 COLOR					
△1	10. 5. 24	形状変更 Form change.	熊倉	草野										
記号 No.	年月日 DATE	変更記事 REVISION RECORD	設計 DESIGN	承認 APP	製品名 NAME			SJHコネクタ (ボス付 ストレート型) SJH Connector, Straight type with boss						
承認 APPROVED	K. Kusano		確認 CHECKED	K. Koizumi		一般公差 TOLERANCE	±0.3		尺度 SCALE	4 / 1		図番 DRAWING No.	JC-1079-05	
設計 DESIGN	A. Kumakura		製図 DRAWING	T. Murakami										

Poles	A	B	C
2	6.0	6.0	2.0
3	8.0	8.0	4.0

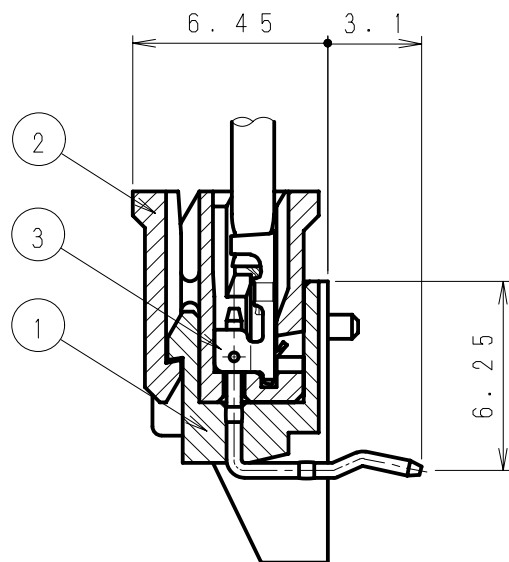
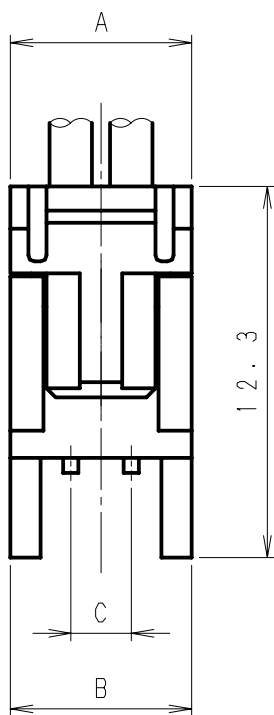

No.	製品番号 PRODUCT NO.	製品名 PRODUCT NAME	材質 MATERIAL
①	SJH2K-□□WLB	ウェハー Wafer	ナイロン66 (UL94V-0) Nylon66 (UL94V-0) 黄銅 (スズメッキ) Brass (Tin Plating)
②	SJH2K-□□HG	ハウジング Housing	ナイロン66 (UL94V-0) Nylon66 (UL94V-0)
③	720374-2MAC	ターミナル Terminal	リン青銅 (スズメッキ材) Phosphor bronze (Pre-tin Plated)
	720474-2MAC		

極数 Poles	2~3	
適用電線 Wire Size	720474	AWG#22~#24
	720374	AWG#24~#30
被覆外径 Insulation Dia.	720474	φ1.1~φ1.6mm
	720374	φ0.8~φ1.5mm

△3	製品番号 PRODUCT No.	No.	材 料 MATERIAL	備考 NOTE	色 COLOR
記号 No.	年月日 DATE	変更記事 REVISION RECORD	設計 DESIGN	承認 APP	製品名 SJHコネクタ (ボス付 アングル型) NAME SJH Connector, Angle type with boss				
承認 APPROVED	確認 CHECKED		一般公差 TOLERANCE		尺度 SCALE	図番 DRAWING No.			
K. Kusano		K. Koizumi		±0.3		4 / 1		JC-1079-06	
設計 DESIGN		製図 DRAWING		JAPAN AUTOMATIC MACHINE CO., LTD.					
A. Kumakura		T. Murakami							

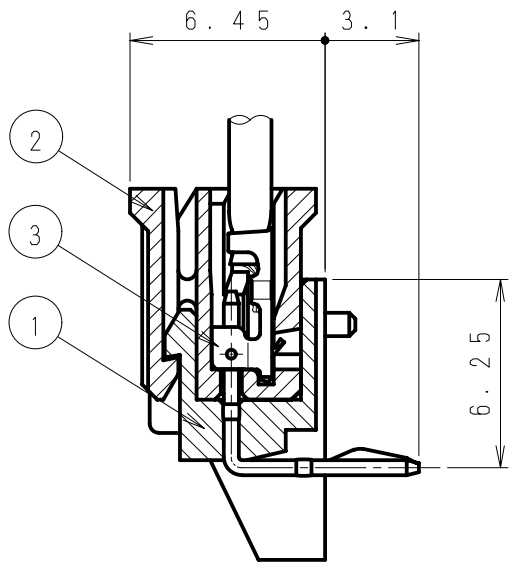
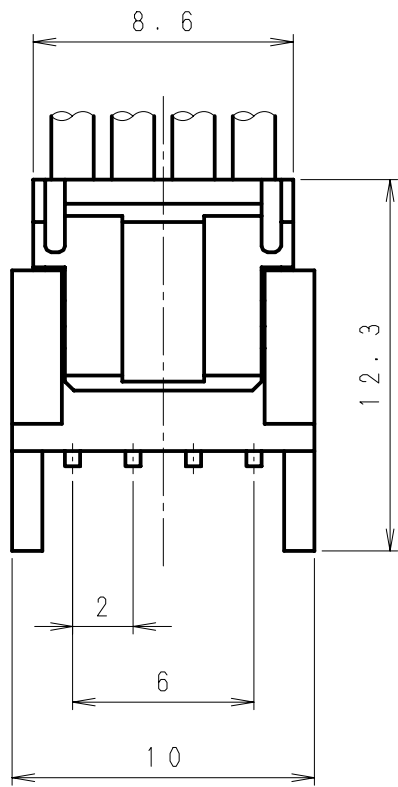

No.	製品番号 PRODUCT NO.	製品名 PRODUCT NAME	材質 MATERIAL
①	SJH2K-04WLB	ウエハー Wafer	ナイロン66 (UL94V-0) Nylon66 (UL94V-0) 黄銅 (スズメッキ) Brass (Tin Plating)
②	SJH2K-04HG	ハウジング Housing	ナイロン66 (UL94V-0) Nylon66 (UL94V-0)
③	720374-2MAC	ターミナル Terminal	リン青銅 (スズメッキ材) Phosphor bronze (Pre-tin Plated)
	720474-2MAC		

極数 Poles	4	
適用電線 Wire Size	720474	AWG#22~#24
	720374	AWG#24~#30
被覆外径 Insulation Dia.	720474	φ1.1~φ1.6mm
	720374	φ0.8~φ1.5mm

△	.	.											
△	.	.	製品番号 PRODUCT No.	No.	材 料 MATERIAL	備考 NOTE	色 COLOR						
△	.	.											
記号 No.	年月日 DATE	変更記事 REVISION RECORD	設計 DESIGN	承認 APP	製品名 NAME			SJHコネクタ (ボス付 アングル型) SJH Connector, Angle type with boss					
承認 APPROVED	K. Kusano		確認 CHECKED	K. Koizumi		一般公差 TOLERANCE	±0.3	尺度 SCALE	4 / 1		図番 DRAWING No.	JC-1079-07	
設計 DESIGN	A. Kumakura		製図 DRAWING	T. Murakami									

Poles	A	B	C
5	10.6	12.0	8.0
6	12.6	14.0	10.0
7	14.6	16.0	12.0

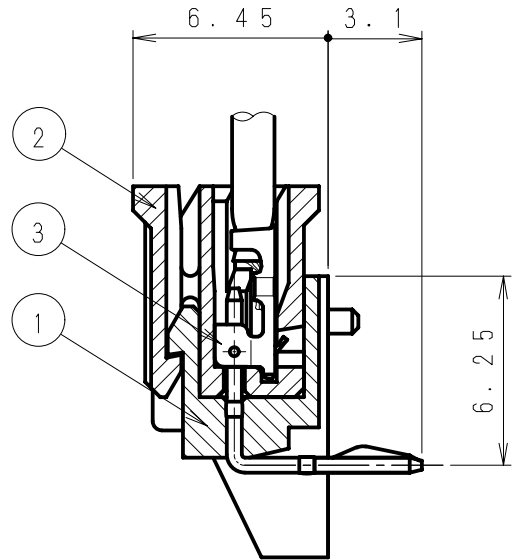
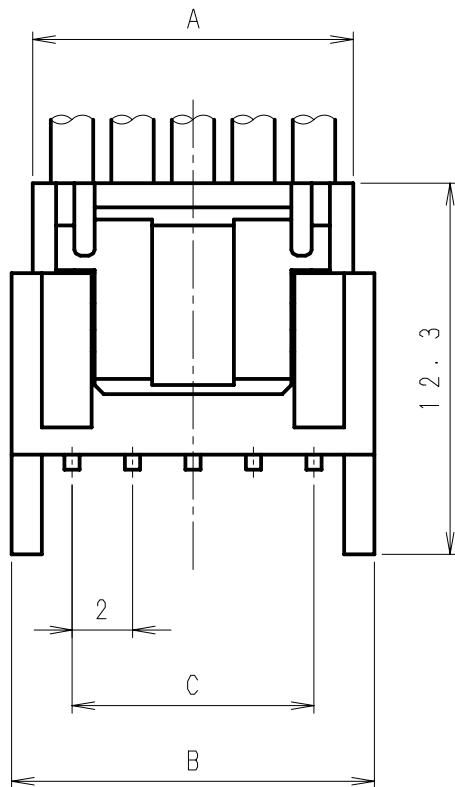

No.	製品番号 PRODUCT NO.	製品名 PRODUCT NAME	材質 MATERIAL
①	SJH2K-□WLB	ウエハー Wafer	ナイロン66 (UL94V-0) Nylon66 (UL94V-0) 黄銅 (スズメッキ) Brass (Tin Plating)
②	SJH2K-□DHG	ハウジング Housing	ナイロン66 (UL94V-0) Nylon66 (UL94V-0)
③	720374-2MAC	ターミナル Terminal	リン青銅 (スズメッキ材) Phosphor bronze (Pre-tin Plated)
	720474-2MAC		

極数 Poles	5~7	
適用電線 Wire Size	720474	AWG#22~#24
	720374	AWG#24~#30
被覆外径 Insulation Dia.	720474	φ1.1~φ1.6mm
	720374	φ0.8~φ1.5mm

△3	製品番号 PRODUCT No.	No.	材 料 MATERIAL	備考 NOTE	色 COLOR
記号 No.	年月日 DATE	変更記事 REVISION RECORD	設計 DESIGN	承認 APP	製品名 SJHコネクタ (ボス付 アングル型) NAME SJH Connector, Angle type with aboss				
承認 APPROVED	確認 CHECKED		一般公差 TOLERANCE		尺度 SCALE	図番 DRAWING No.			
K. Kusano		K. Koizumi		±0.3		4/1		JC-1079-08	
設計 DESIGN		製図 DRAWING		JAPAN AUTOMATIC MACHINE CO., LTD.					
A. Kumakura		T. Murakami							

Poles	A	B	C	Poles	A	B	C
8	16.6	18.0	14.0	13	26.6	28.0	24.0
9	18.6	20.0	16.0	14	28.6	30.0	26.0
10	20.6	22.0	18.0	15	30.6	32.0	28.0
11	22.6	24.0	20.0	16	32.6	34.0	30.0
12	24.6	26.0	22.0	—	—	—	—

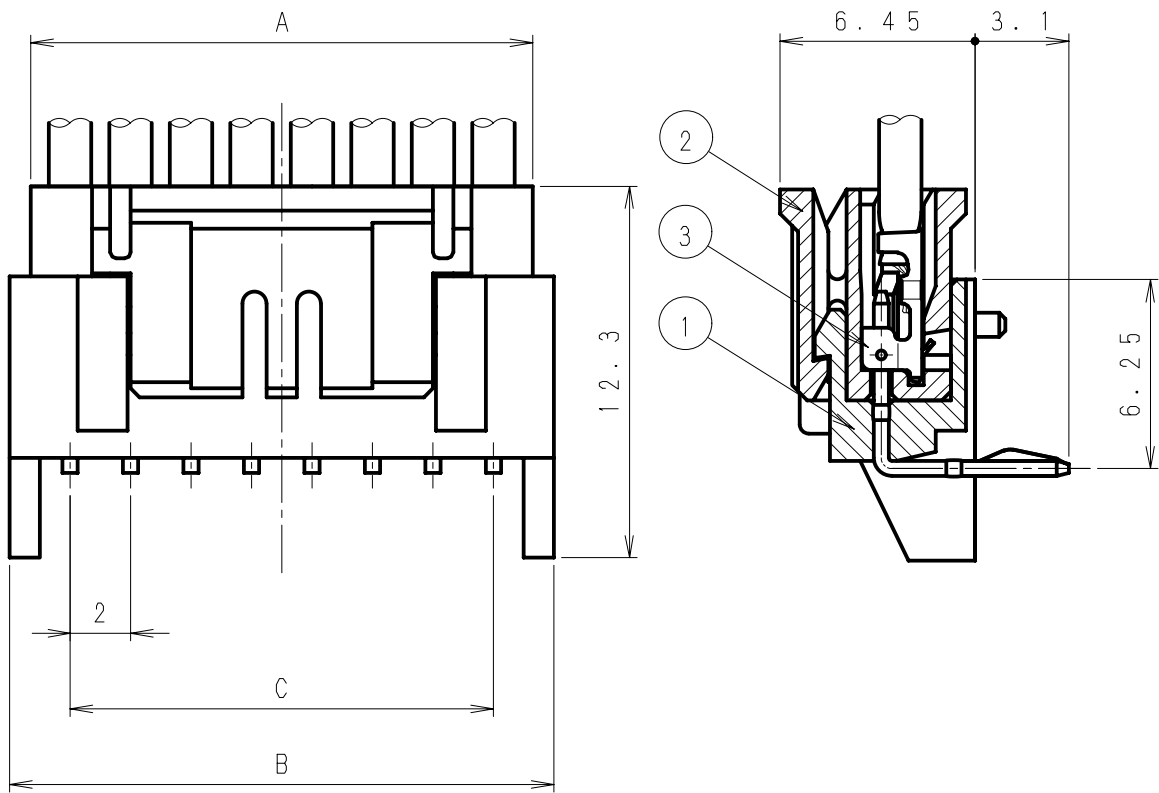

No.	製品番号 PRODUCT NO.	製品名 PRODUCT NAME	材質 MATERIAL
①	SJH2K-□□WLB	ウエハー Wafer	ナイロン66 (UL94V-0) Nylon66 (UL94V-0) 黄銅 (スズメッキ) Brass (Tin Plating)
②	SJH2K-□□HG	ハウジング Housing	ナイロン66 (UL94V-0) Nylon66 (UL94V-0)
③	720374-2MAC 720474-2MAC	ターミナル Terminal	リン青銅 (スズメッキ材) Phosphor bronze (Pre-tin Plated)

極数 Poles	8 ~ 16	
適用電線 Wire Size	720474	AWG#22 ~ #24
	720374	AWG#24 ~ #30
被覆外径 Insulation Dia.	720474	φ1.1 ~ φ1.6mm
	720374	φ0.8 ~ φ1.5mm

△3	製品番号 PRODUCT No.	No.	材 料 MATERIAL	備考 NOTE	色 COLOR
記号 No.	年月日 DATE	変更記事 REVISION RECORD	設計 DESIGN	承認 APP	製品名 SJHコネクタ (ボス付 アングル型) NAME SJH Connector, Angle type with boss				
承認 APPROVED	確認 CHECKED		一般公差 TOLERANCE		尺度 SCALE	図番 DRAWING No.			
K. Kusano		K. Koizumi		±0.3		4 / 1		JC-1079-09	
設計 DESIGN		製図 DRAWING		JAPAN AUTOMATIC MACHINE CO., LTD.					
A. Kumakura		T. Murakami							

第三角法
3rd ANGLE PROJECTION

単位: mm 注) 図面を実測しないこと
UNIT: mm NOTES) DO NOT SCALE

図番 DRAWING No.
JC-0950-09Z

極番刻印
Pole No. Mark

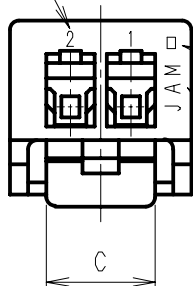

□はキャビNo刻印 (A~P)
CAV No. mark (A~P)
"JAM" 社名刻印
"JAM" Mark

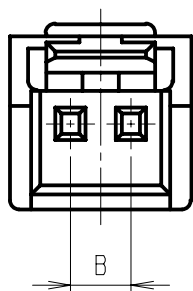
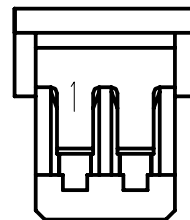
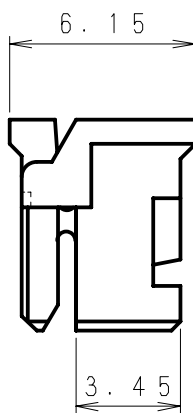
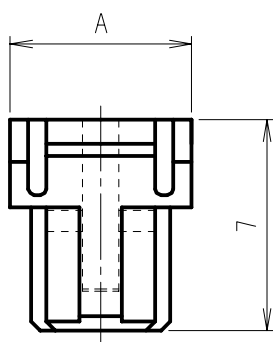

極数 Poles	A	B	C
2	6.0	2.0	3.6
3	8.0	4.0	4.4

△5	. .								
△4	. .								
△3	. .				SJH2K-□□HG		ナイロン66 Nylon66	UL94V-0	
△2	. .				製品番号 PRODUCT No.	No.	材 料 MATERIAL	備考 NOTE	
△1	. .							色 COLOR	
記号 No.	年月日 DATE	変更記事 REVISION RECORD	設計 DESIGN	承認 APP			製品名 NAME	SJHハウジング SJH Housing	
承認 APPROVED	K. Kusano	確認 CHECKED	A. Kumakura	一般公差 TOLERANCE	±0.3	尺度 SCALE	4/1	図番 DRAWING No.	JC-0950-09Z
設計 DESIGN	Y. Shimizu	製図 DRAWING	Y. Shimizu	 JAPAN AUTOMATIC MACHINE CO., LTD.					

第三角法
3rd ANGLE PROJECTION

単位: mm
UNIT: mm
注) 図面を実測しないこと
NOTES) DO NOT SCALE

図番 DRAWING No.
JC-0950-10Z

極番刻印
Pole No. Mark

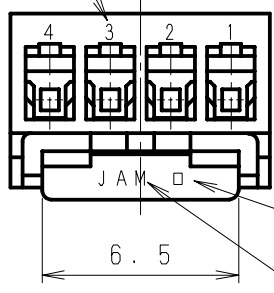

□はキャビNo刻印 (A~P)
CAV No. mark (A~P)
"JAM" 社名刻印
"JAM" Mark

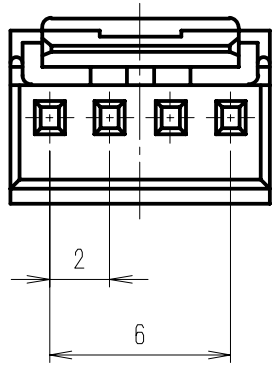
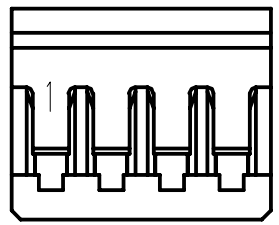
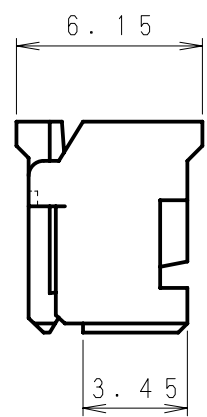
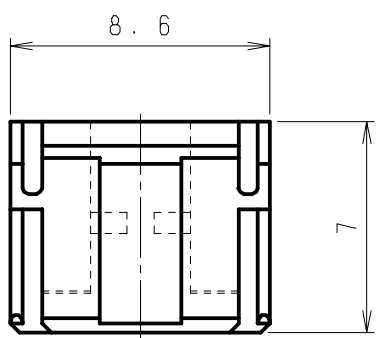

△5	. .									
△4	. .									
△3	. .					SJH2K-04HG		ナイロン66 Nylon66	UL94V-0	
△2	. .					製品番号 PRODUCT No.	No.	材 料 MATERIAL	備考 NOTE	色 COLOR
△1	. .					記号 No.	年月日 DATE	変更記事 REVISION RECORD	設計 DESIGN	承認 APP
承認 APPROVED K. Kusano		確認 CHECKED A. Kumakura		一般公差 TOLERANCE ±0.3		尺度 SCALE 4/1		製品名 NAME SJHハウジング SJH Housing		
設計 DESIGN Y. Shimizu		製図 DRAWING Y. Shimizu		図番 DRAWING No. JC-0950-10Z						

第三角法
3rd ANGLE PROJECTION

単位: mm
UNIT: mm
注) 図面を実測しないこと
NOTES) DO NOT SCALE

図番 DRAWING No.
JC-0950-11Z

極番刻印
Pole No. Mark

"JAM" 社名刻印
"JAM" Mark

□はキャビNo刻印 (A~P)
CAV No. mark (A~P)

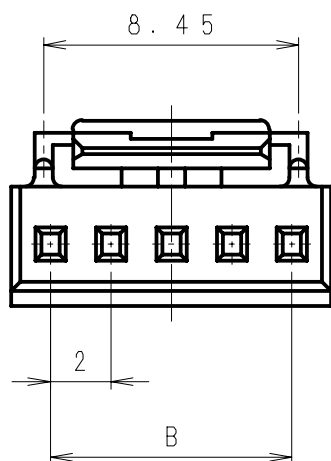
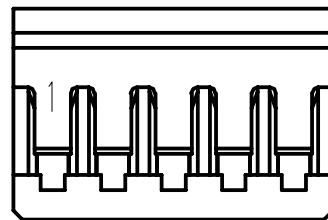
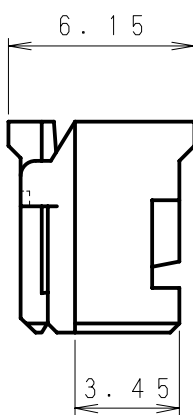
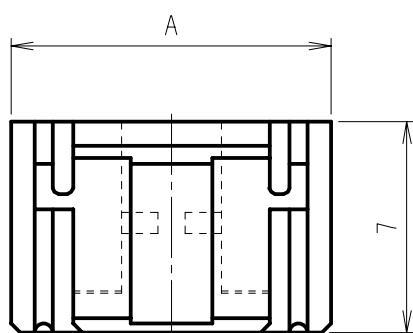
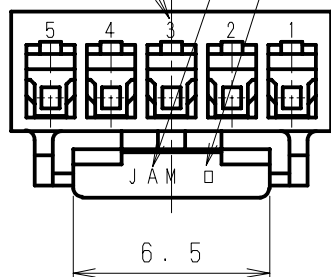

極数 Poles	A	B
5	10.6	8.0
6	12.6	10.0
7	14.6	12.0

△5	. .							
△4	. .							
△3	. .				SJH2K-□□HG		ナイロン66 Nylon66	UL94V-0
△2	. .				製品番号 PRODUCT No.	No.	材 料 MATERIAL	備考 NOTE
△1	. .							色 COLOR
記号 No.	年月日 DATE	変更記事 REVISION RECORD	設計 DESIGN	承認 APP	製品名 NAME		SJHハウジング SJH Housing	
承認 APPROVED	確認 CHECKED		一般公差 TOLERANCE		尺度 SCALE	図番 DRAWING No.		
K. Kusano	A. Kumakura		±0.3		4/1	JC-0950-11Z		
設計 DESIGN	製図 DRAWING		 JAPAN AUTOMATIC MACHINE CO., LTD.					
Y. Shimizu	Y. Shimizu							

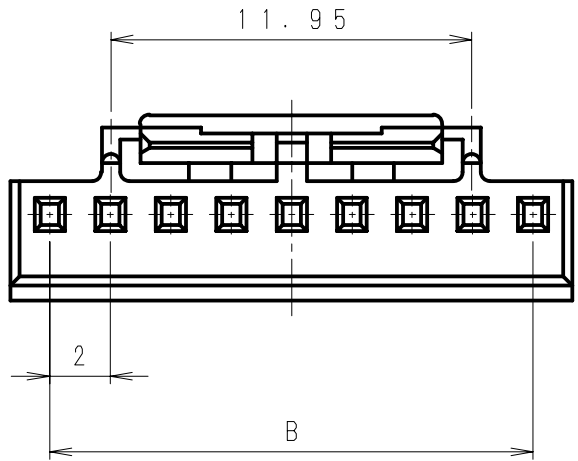
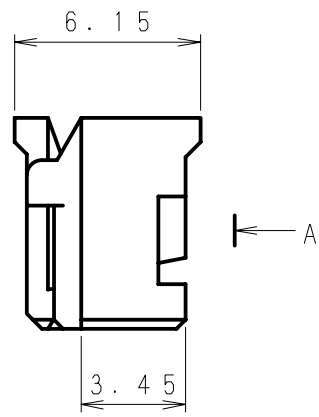
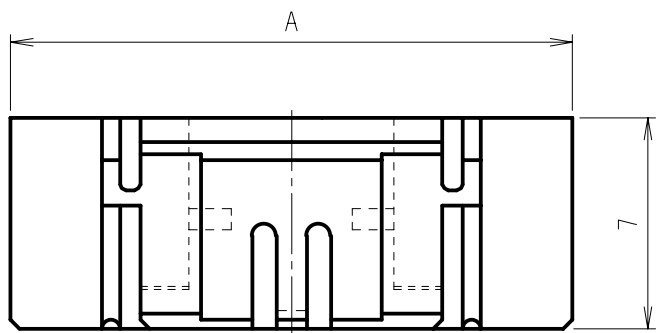
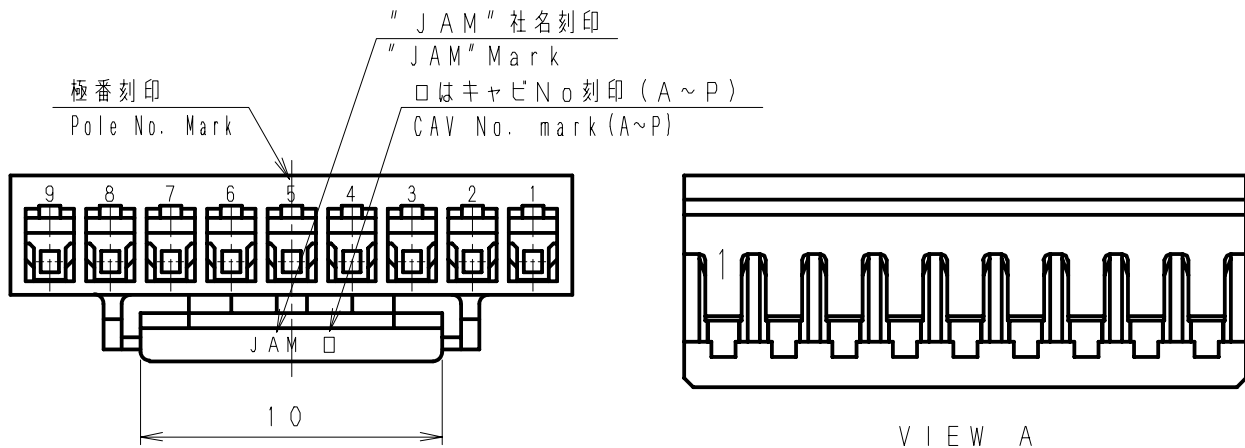

極数 Poles	A	B
8	16.6	14.0
9	18.6	16.0
10	20.6	18.0
11	22.6	20.0
12	24.6	22.0
13	26.6	24.0
14	28.6	26.0
15	30.6	28.0
16	32.6	30.0

△5	. .								
△4	. .				SJH2K-□□HG		ナイロン66 Nylon66	UL94V-0	
△3	. .				製品番号 PRODUCT No.	No.	材 料 MATERIAL	備考 NOTE	色 COLOR
△2	. .								
△1	. .								
記号 No.	年月日 DATE	変更記事 REVISION RECORD	設計 DESIGN	承認 APP	製品名 NAME		SJHハウジング SJH Housing		
承認 APPROVED	確認 CHECKED		一般公差 TOLERANCE		尺度 SCALE	図番 DRAWING No.			
K. Kusano	A. Kumakura		±0.3		4/1	JC-0950-12Z			
設計 DESIGN	製図 DRAWING								
Y. Shimizu	Y. Shimizu								

第三角法
3rd ANGLE PROJECTION

単位: mm 注) 図面を実測しないこと
UNIT: mm NOTES) DO NOT SCALE

図番 DRAWING No.
JC-1079-10

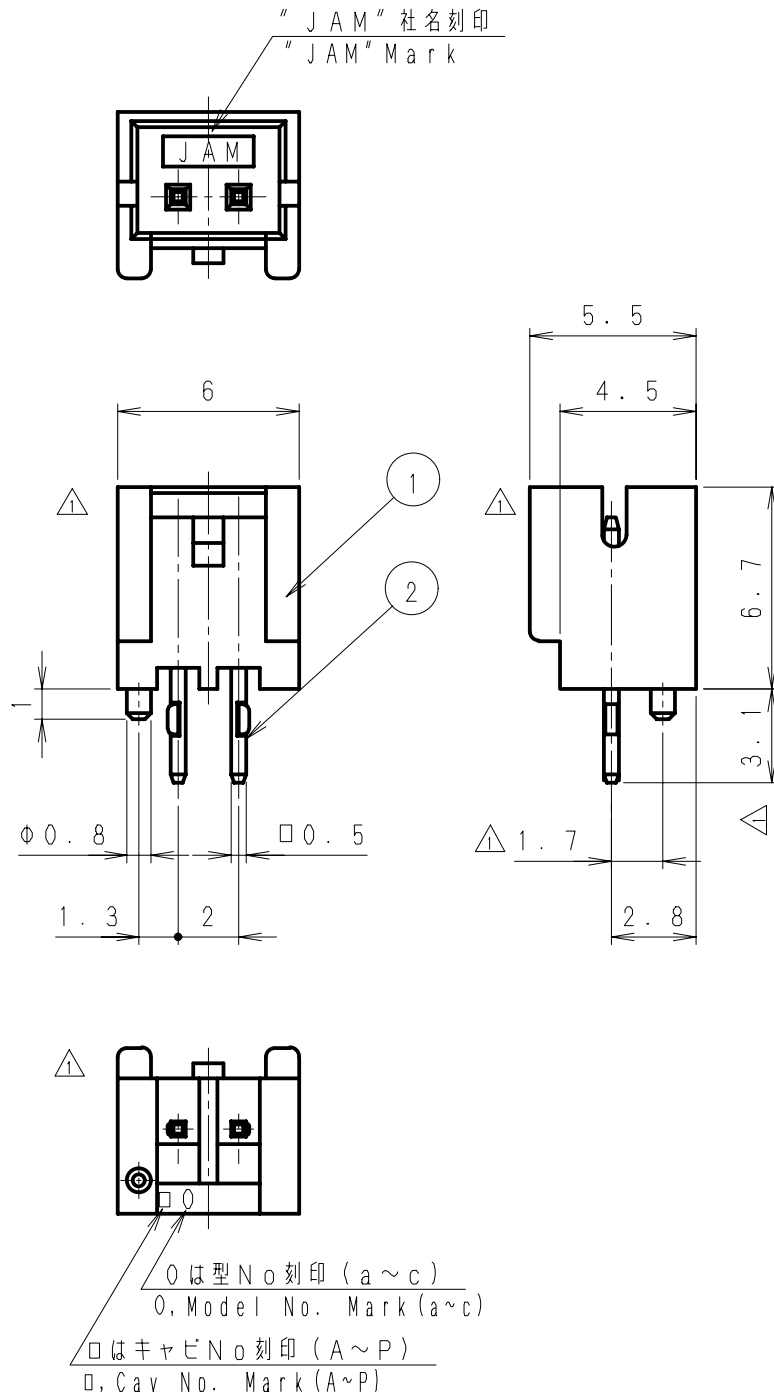

△6	. .								
△5	. .								
△4	. .				SJH2K-02WSKB	②	黄銅 Brass	スズ銅メッキ Sn-Cu Plating	
△3	. .					①	ナイロン66 Nylon 66	UL94V-0	
△2	. .				製品番号 PRODUCT No.	No.	材 料 MATERIAL	備考 NOTE	色 COLOR
△1	10. 5. 24	形状変更 Form change.	熊倉 草野						
記号 No.	年月日 DATE	変更記事 REVISION RECORD	設計 DESIGN	承認 APP			製品名 SJHウエハー (ボス付 ストレート型) NAME SJH Wafer, Straight type with boss		
承認 APPROVED	確認 CHECKED		一般公差 TOLERANCE		尺度 SCALE	図番 DRAWING No.			
K. Kusano	A. Kumakura		±0.3		4 / 1	JC-1079-10			
設計 DESIGN	製図 DRAWING		JAPAN AUTOMATIC MACHINE CO., LTD.						
A. Kumakura	Y. Shimizu								

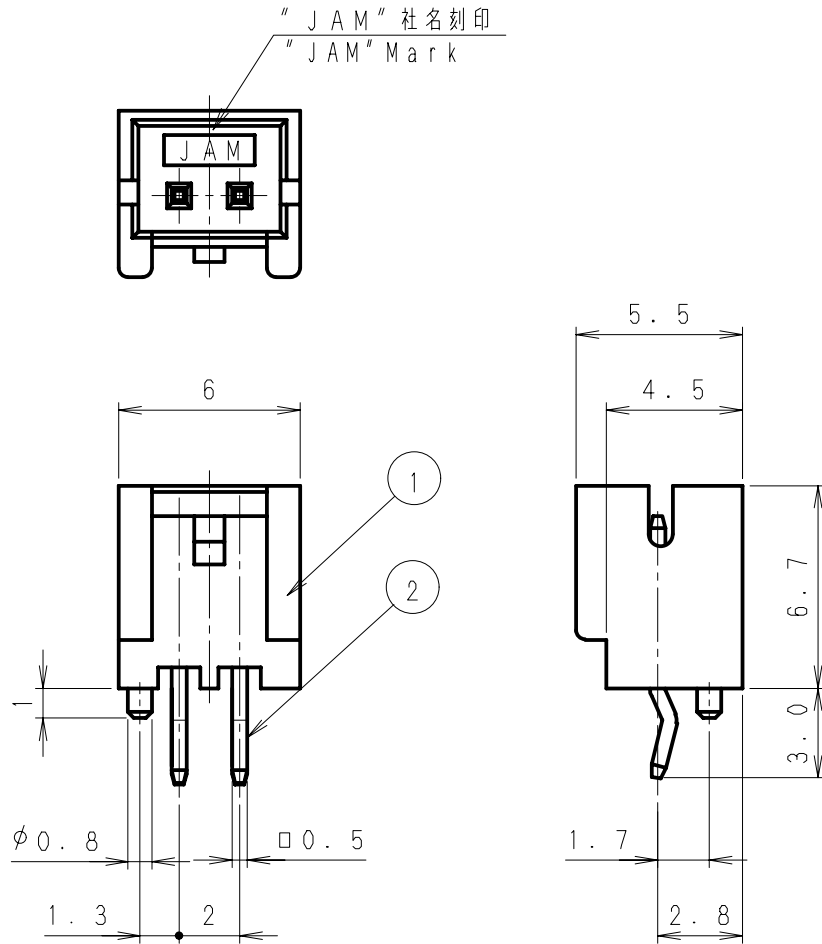

○は型No刻印 (a~c)
 O, Model No. Mark (a~c)
 □はキャビNo刻印 (A~P)
 □, Cav No. Mark (A~P)

△6	. .								
△5	. .								
△4	. .				②	黄銅 Brass	スズメッキ Tin Plating		
△3	. .			SJH2K-02WSB	①	ナイロン66 Nylon 66	UL94V-0		
△2	. .			製品番号 PRODUCT No.	No.	材 料 MATERIAL	備 考 NOTE	色 COLOR	
△1	. .								
記号 No.	年月日 DATE	変更記事 REVISION RECORD	設計 DESIGN	承認 APP	製品名 NAME		SJHウエハー(ボス付 ストレート型) SJH Wafer, Straight type with boss		
承認 APPROVED	確認 CHECKED		一般公差 TOLERANCE		尺度 SCALE	図番 DRAWING No.			
K. Kusano	A. Kumakura		±0.3		4/1	JC-1079-19			
設計 DESIGN	製図 DRAWING								
A. Kumakura	Y. Shimizu								

第三角法
3rd ANGLE PROJECTION

単位: mm 注) 図面を実測しないこと
UNIT: mm NOTES) DO NOT SCALE

図番 DRAWING No.
JC-1079-11

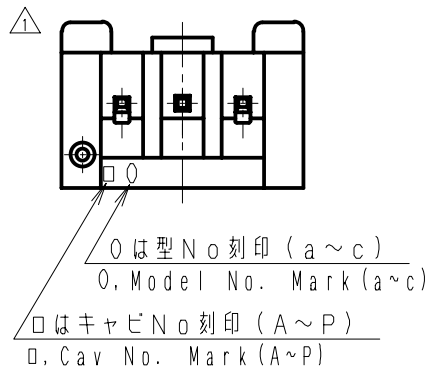
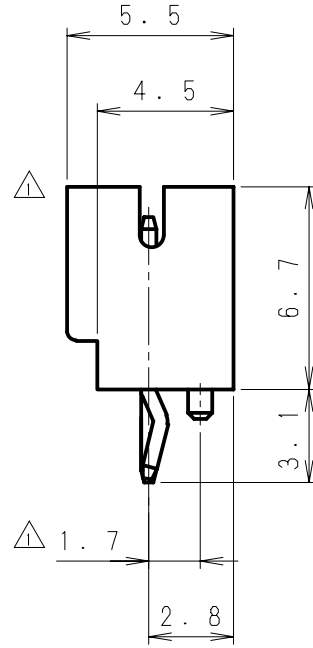
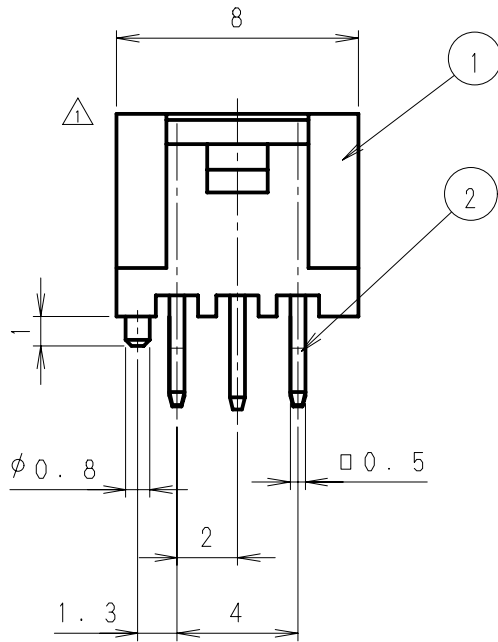
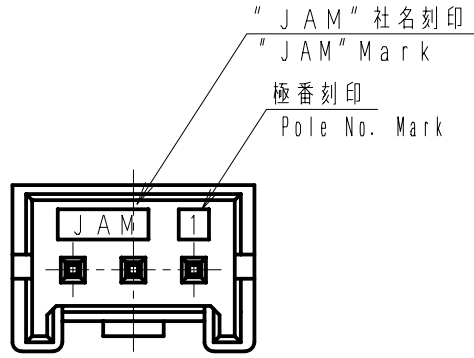

△6	. .							
△5	. .							
△4	. .				②	黄銅 Brass	スズメッキ Tin Plating	
△3	. .				①	ナイロン66 Nylon 66	UL94V-0	
△2	. .							
△1	10. 5. 24	形状変更 Form change.	熊倉 草野	製品番号 PRODUCT No.	No.	材 料 MATERIAL	備考 NOTE	色 COLOR
記号 No.	年月日 DATE	変更記事 REVISION RECORD	設計承認 DESIGN APP	製品名 NAME		SJHウエハー (ボス付 ストレート型) SJH Wafer, Straight type with boss		
承認 APPROVED	K. Kusano	確認 CHECKED	A. Kumakura	一般公差 TOLERANCE	±0.3	尺度 SCALE	4/1	図番 DRAWING No.
						JC-1079-11		
設計 DESIGN		製図 DRAWING		JAPAN AUTOMATIC MACHINE CO., LTD.				
A. Kumakura		Y. Shimizu						

第三角法
3rd ANGLE PROJECTION

単位：mm 注)... 図面を実測しないこと
UNIT: mm NOTES)... DO NOT SCALE

図番 DRAWING No.
JC-1079-12

Poles	A	B
4	10.0	6.0
5	12.0	8.0
6	14.0	10.0
7	16.0	12.0

最終極番刻印
Last Pole No. Mark

"JAM" 社名刻印
"JAM" Mark

極番刻印
Pole No. Mark

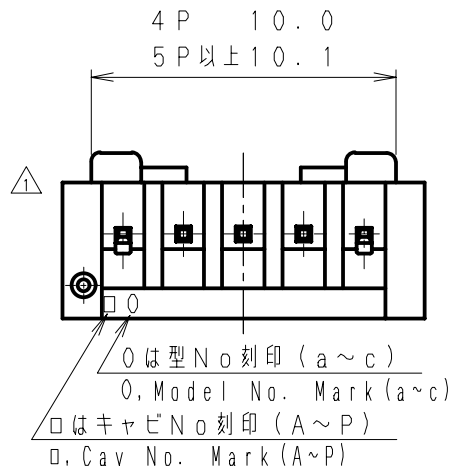
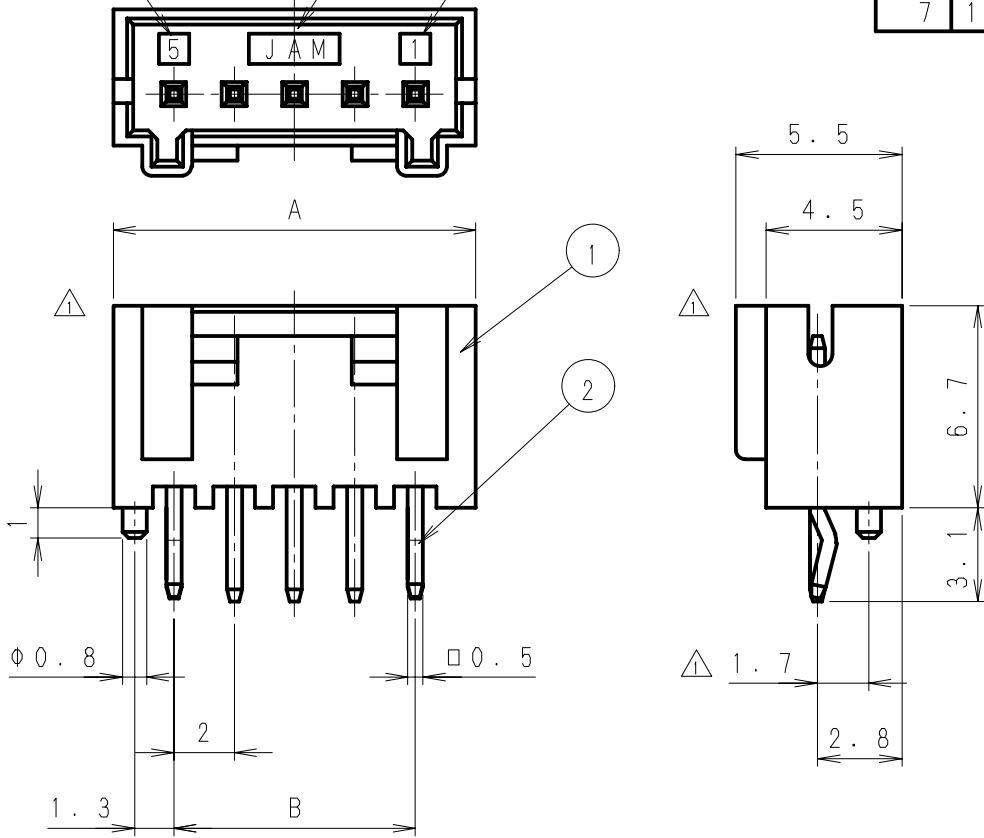

△6	..								
△5	..								
△4	..				2	黄銅 Brass	スズメッキ Tin Plating		
△3	..				1	ナイロン66 Nylon 66	UL94V-0		
△2	..								
△1	10. 5. 24	形状変更 Form change.	熊倉 草野		製品番号 PRODUCT No.	材 料 MATERIAL	備考 NOTE	色 COLOR	
記号 No.	年月日 DATE	変更記事 REVISION RECORD	設計 DESIGN	承認 APP		製品名 SJHウエハー(ボス付 ストレート型) NAME SJH Wafer, Straight type with boss			
承認 APPROVED	K. Kusano	確認 CHECKED	A. Kumakura	一般公差 TOLERANCE	±0.3	尺度 SCALE	4/1	図番 DRAWING No.	
設計 DESIGN	A. Kumakura	製図 DRAWING	Y. Shimizu	JAPAN AUTOMATIC MACHINE CO., LTD.					JC-1079-12

第三角法
3rd ANGLE PROJECTION

単位: mm
UNIT: mm
注) 図面を実測しないこと
NOTES) DO NOT SCALE

図番 DRAWING No.
JC-1079-13

Poles	A	B	Poles	A	B
8	18.0	14.0	13	28.0	24.0
9	20.0	16.0	14	30.0	26.0
10	22.0	18.0	15	32.0	28.0
11	24.0	20.0	16	34.0	30.0
12	26.0	22.0	—	—	—

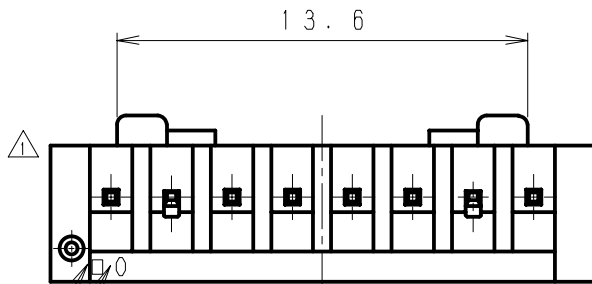
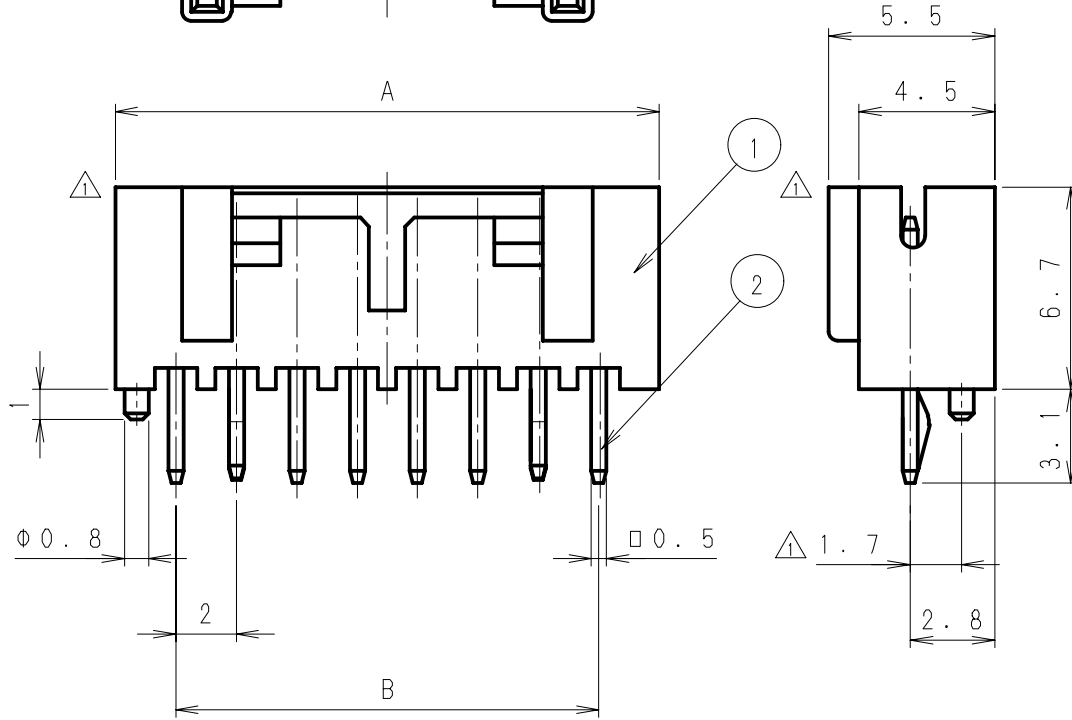
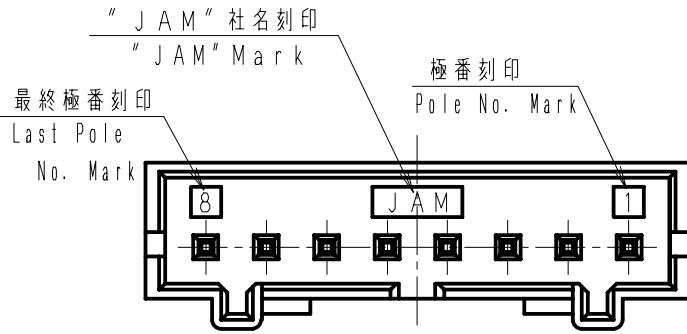

○は型No刻印 (a~c)
O, Model No. Mark (a~c)
□はキャビNo刻印 (A~P)
□, Cav No. Mark (A~P)

△6	. . .								
△5	. . .								
△4	. . .								
△3	. . .								
△2	. . .								
△1	10. 5. 24	形状変更 Form change.	熊倉	草野	SJH2K-00WSB	2 1	黄銅 Brass ナイロン66 Nylon 66	スズメッキ Tin Plating UL94V-0	
記号 No.	年月日 DATE	変更記事 REVISION RECORD	設計 DESIGN	承認 APP	製品番号 PRODUCT No.	No.	材 料 MATERIAL	備考 NOTE	色 COLOR
承認 APPROVED	K. Kusano	確認 CHECKED	A. Kumakura	一般公差 TOLERANCE	±0.3	尺度 SCALE	4 / 1	図番 DRAWING No.	JC-1079-13
設計 DESIGN	A. Kumakura	製図 DRAWING	Y. Shimizu	JAPAN AUTOMATIC MACHINE CO., LTD.					

第三角法
3rd ANGLE PROJECTION

単位: mm
UNIT: mm
注) 図面を実測しないこと
NOTES) DO NOT SCALE

図番 DRAWING No.
JC-1079-14

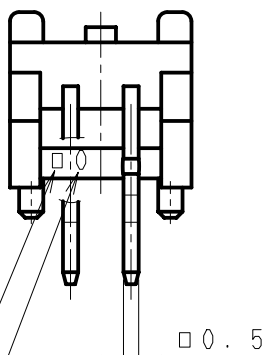
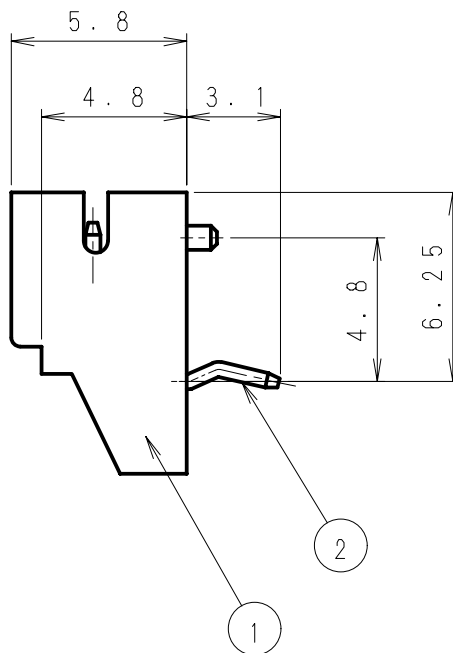
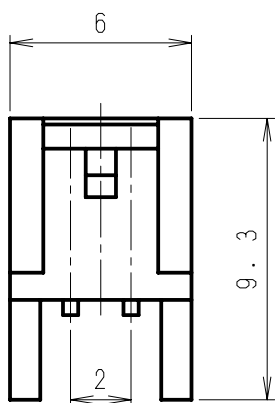
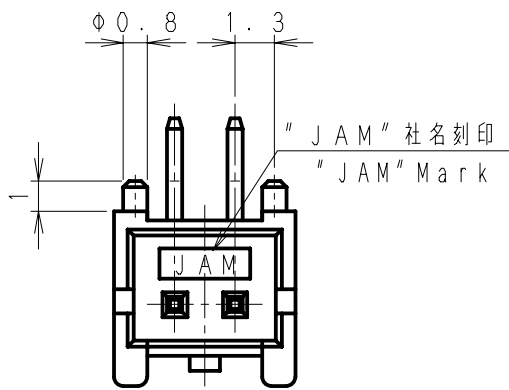

○は型No刻印 (a~c)
O, Model No. Mark (a~c)

□はキャビNo刻印 (A~P)
□, Cav No. Mark (A~P)

△6	. .								
△5	. .								
△4	. .					②	黄銅 Brass	スズメッキ Tin Plating	
△3	. .				SJH2K-02WLB	①	ナイロン66 Nylon 66	UL94V-0	
△2	. .				製品番号 PRODUCT No.	No.	材 料 MATERIAL	備考 NOTE	色 COLOR
△1	. .								
記号 No.	年月日 DATE	変更記事 REVISION RECORD	設計 DESIGN	承認 APP			製品名 NAME	SJHウエハー (ボス付 アングル型) SJH Wafer, Angle type with boss	
承認 APPROVED	確認 CHECKED		一般公差 TOLERANCE		尺度 SCALE	図番 DRAWING No.			
K. Kusano	A. Kumakura		±0.3		4 / 1	JC-1079-14			
設計 DESIGN	製図 DRAWING		JAPAN AUTOMATIC MACHINE CO., LTD.						
A. Kumakura	Y. Shimizu								

第三角法
3rd ANGLE PROJECTION

単位: mm
UNIT: mm
注) 図面を実測しないこと
NOTES) DO NOT SCALE

図番 DRAWING No.
JC-1079-15

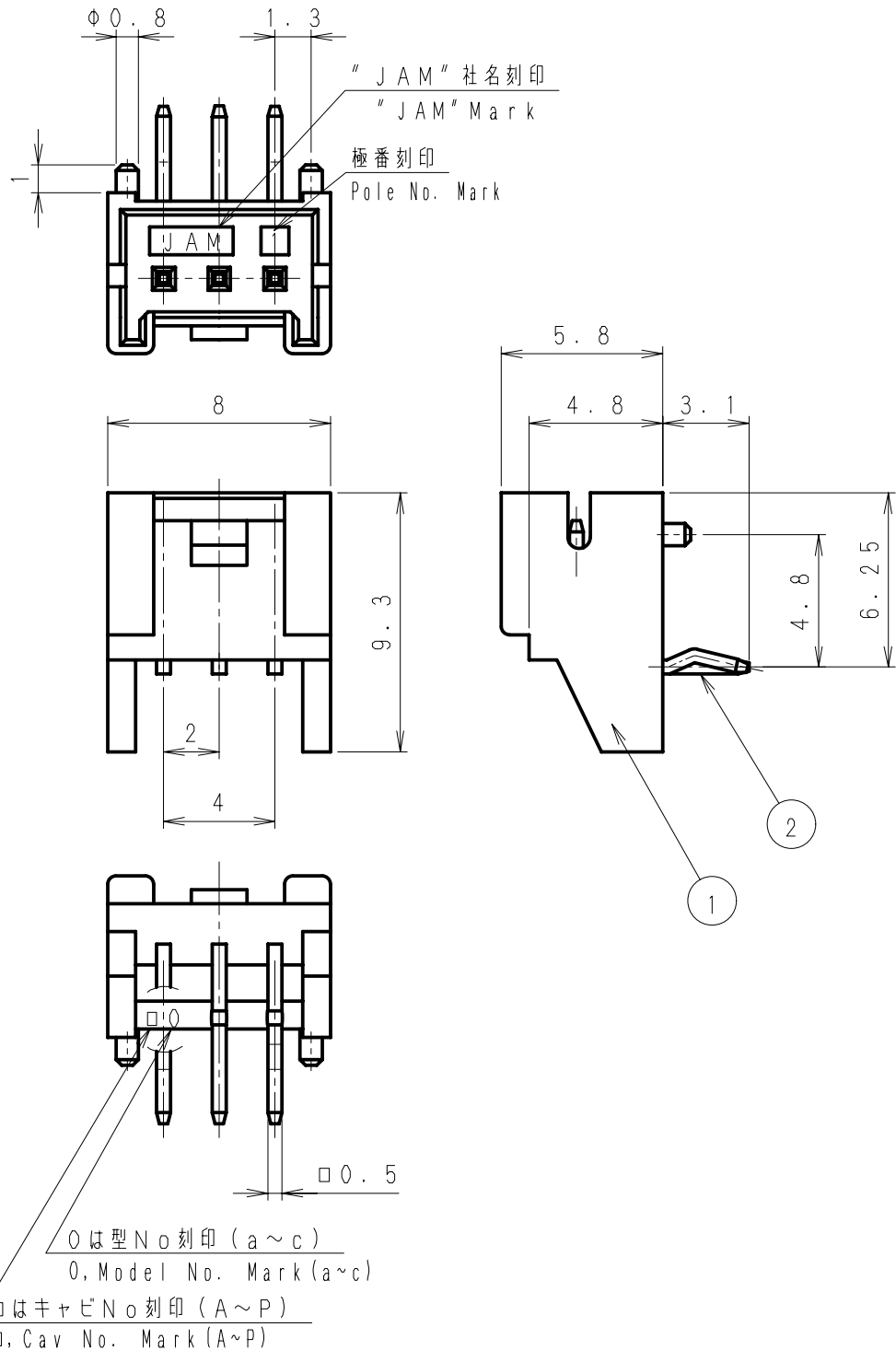

△6	. .								
△5	. .								
△4	. .								
△3	. .								
△2	. .								
△1	. .								
記号 No.	年月日 DATE	変更記事 REVISION RECORD	設計 DESIGN	承認 APP					
承認 APPROVED	K. Kusano	確認 CHECKED	A. Kumakura	一般公差 TOLERANCE	±0.3	尺度 SCALE	4/1	製品名 NAME	SJHウエハー (ボス付 アングル型) SJH Wafer, Angle type with boss
設計 DESIGN	A. Kumakura	製図 DRAWING	Y. Shimizu	図番 DRAWING No.	JC-1079-15				

第三角法
3rd ANGLE PROJECTION

単位: mm
UNIT: mm
注) 図面を実測しないこと
NOTES) DO NOT SCALE

図番 DRAWING No.
JC-1079-16

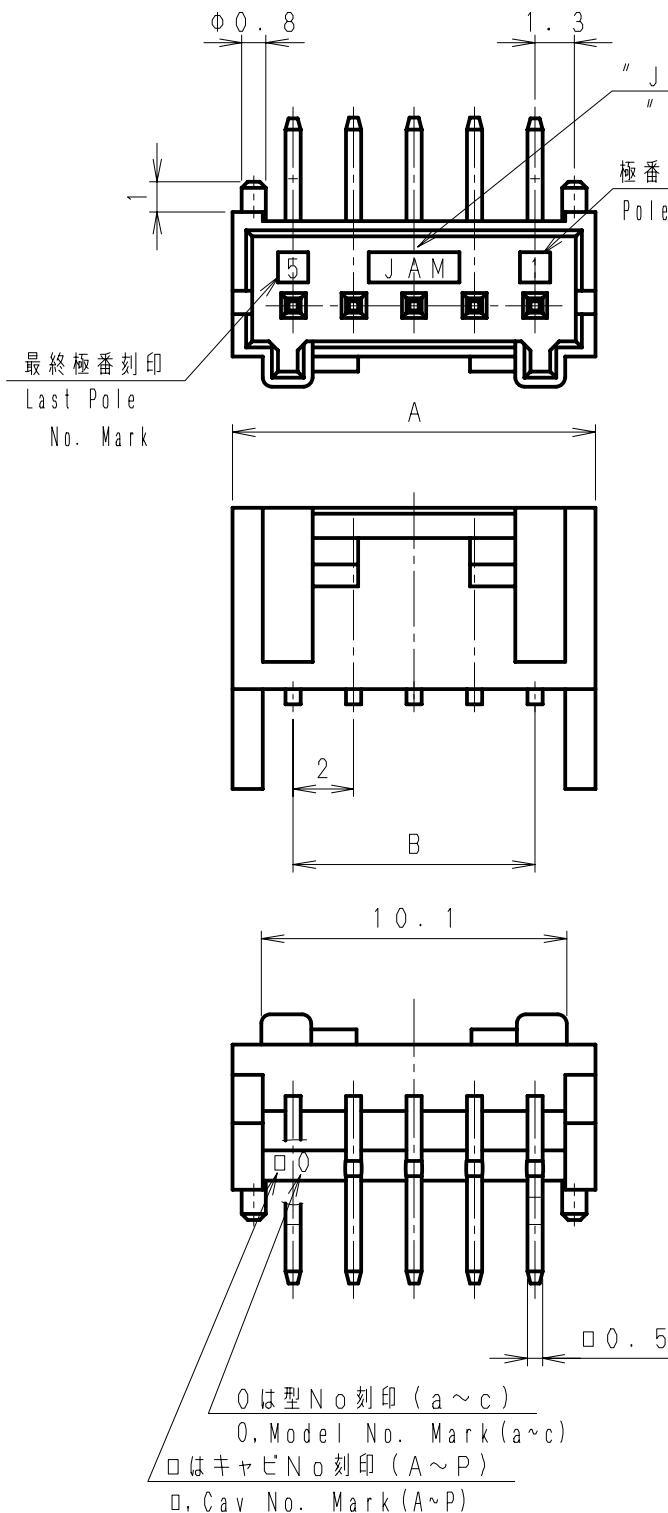

Poles	A	B
4	10.0	6.0
5	12.0	8.0
6	14.0	10.0
7	16.0	12.0

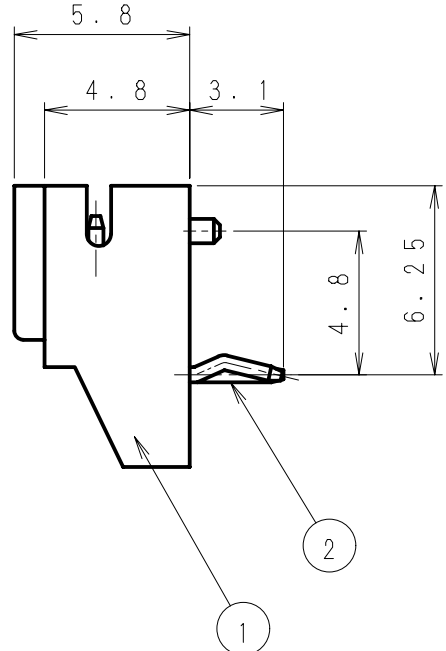

△6	. . .								
△5	. . .								
△4	. . .				2	黄銅 Brass	スズメッキ Tin Plating		
△3	. . .				1	ナイロン66 Nylon 66	UL94V-0		
△2	. . .					製品番号 PRODUCT No.	材料 MATERIAL	備考 NOTE	
△1	. . .				No.			色 COLOR	
記号 No.	年月日 DATE	変更記事 REVISION RECORD	設計 DESIGN	承認 APP		製品名 NAME	SJHウエハー (ボス付 アングル型) SJH Wafer, Angle type with boss		
承認 APPROVED	K. Kusano	確認 CHECKED	A. Kumakura	一般公差 TOLERANCE	±0.3	尺度 SCALE	4/1	図番 DRAWING No.	JC-1079-16
設計 DESIGN	A. Kumakura	製図 DRAWING	Y. Shimizu	JAPAN AUTOMATIC MACHINE CO., LTD.					

第三角法
3rd ANGLE PROJECTION

単位: mm 注) 図面を実測しないこと
UNIT: mm NOTES) DO NOT SCALE

図番 DRAWING No.
JC-1079-17

Poles	A	B	Poles	A	B
8	18.0	14.0	13	28.0	24.0
9	20.0	16.0	14	30.0	26.0
10	22.0	18.0	15	32.0	28.0
11	24.0	20.0	16	34.0	30.0
12	26.0	22.0	—	—	—

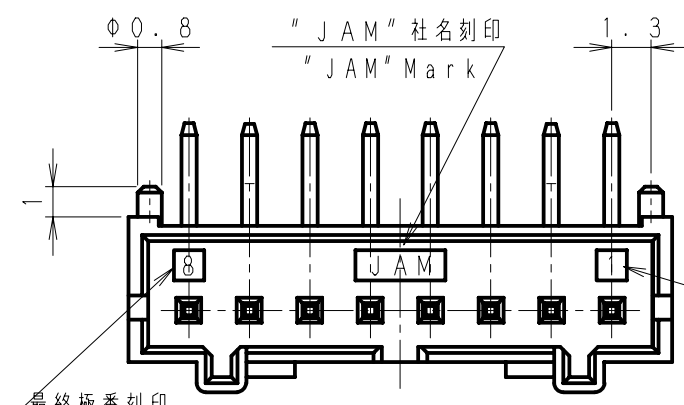

最終極番刻印
Last Pole No. Mark

極番刻印
Pole No. Mark

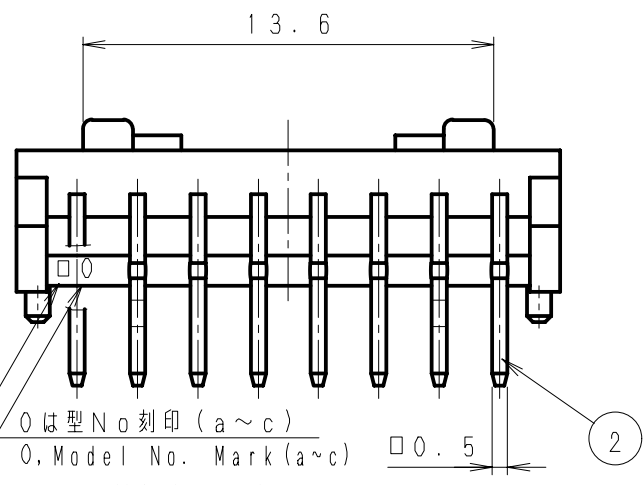
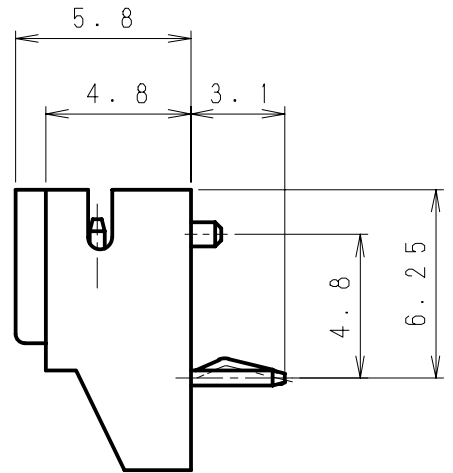
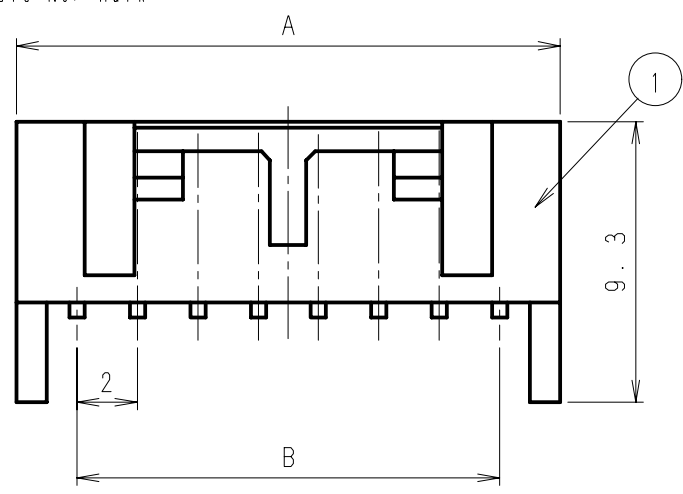

○は型No刻印 (a~c)
O, Model No. Mark (a~c) □0.5

□はキャビNo刻印 (A~P)
□, Cav No. Mark (A~P)

△6	. .								
△5	. .								
△4	. .								
△3	. .				SJH2K-00WLB	② 黄銅 Brass	スズメッキ Tin Plating		
△2	. .					① ナイロン66 Nylon 66	UL94V-0		
△1	. .				製品番号 PRODUCT No.	材 料 MATERIAL	備考 NOTE	色 COLOR	
記号 No.	年月日 DATE	変更記事 REVISION RECORD	設計 DESIGN	承認 APP		製品名 NAME SJHウエハー (ボス付 アングル型) SJH Wafer, Angle type with boss			
承認 APPROVED	K. Kusano	確認 CHECKED	A. Kumakura	一般公差 TOLERANCE	±0.3	尺度 SCALE	4/1	図番 DRAWING No. JC-1079-17	
設計 DESIGN	A. Kumakura	製図 DRAWING	Y. Shimizu	JAPAN AUTOMATIC MACHINE CO., LTD.					

第三角法
3rd ANGLE PROJECTION

単位: mm
UNIT: mm
注) 図面を実測しないこと
NOTES) DO NOT SCALE

図番 DRAWING No.
JC-0810-14Z

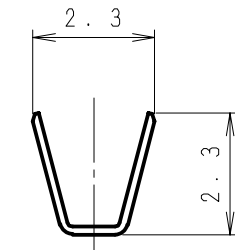
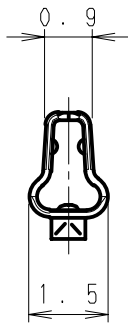
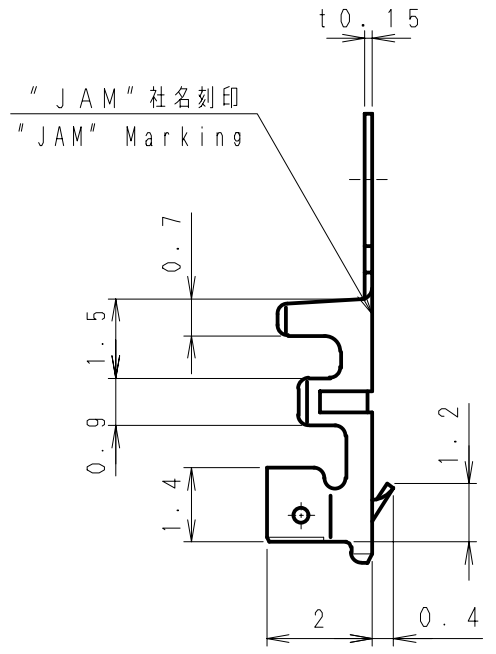
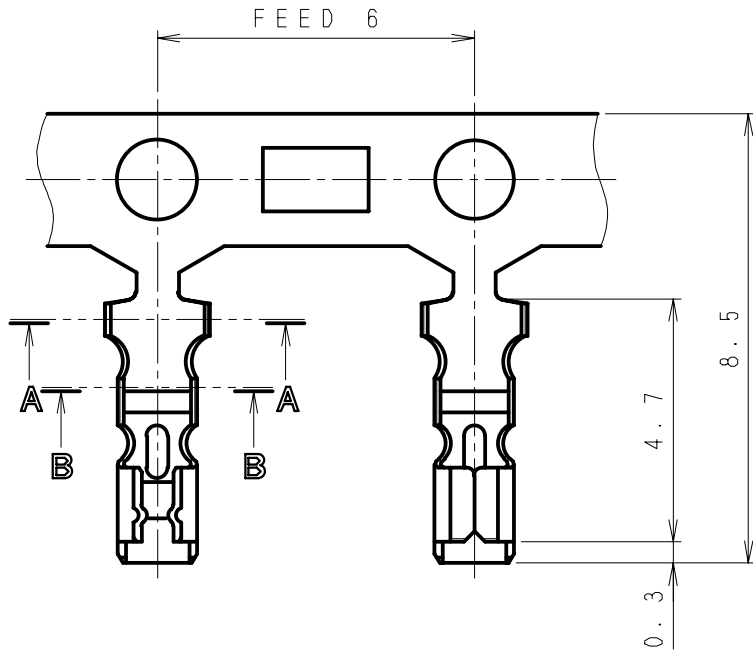

SEC A-A

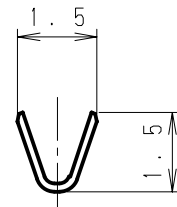

SEC B-B

△6	. .								
△5	. .								
△4	. .								△
△3	. .				720374-2MAC	リン青銅 Phosphor Bronze	スズメッキ材 Pre-tin Plated	AWG#24~#30	φ0.8~φ1.5
△2	. .				製品番号 PRODUCT No.	材 料 MATERIAL	表面処理 FINISH	適用電線 WIRE SIZE	被覆外径 INSULATION DIA
△1	05.12.12	被覆外径変更(範囲指定)	清水	堀内					
記号 No.	年月日 DATE	変更記事 REVISION RECORD	設計 DESIGN	承認 APP	製品名 NAME		ターミナル Terminal		
承認 APPROVED	確認 CHECKED		一般公差 TOLERANCE		尺度 SCALE	図番 DRAWING No.			
Y. Horiuchi	K. Kusano		±0.3		7 / 1	JC-0810-14Z			
設計 DESIGN	製図 DRAWING		 JAPAN AUTOMATIC MACHINE CO., LTD.						
K. Yokoyama	K. Yokoyama								

第三角法
3rd ANGLE PROJECTION

単位: mm
UNIT: mm

注) 図面を実測しないこと
NOTES) DO NOT SCALE

図番 DRAWING No.
JC-0810-15Z

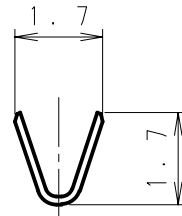
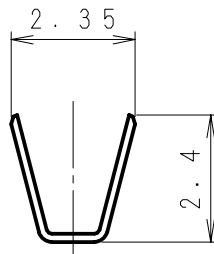
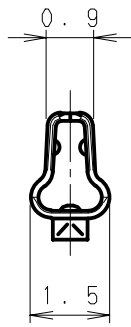
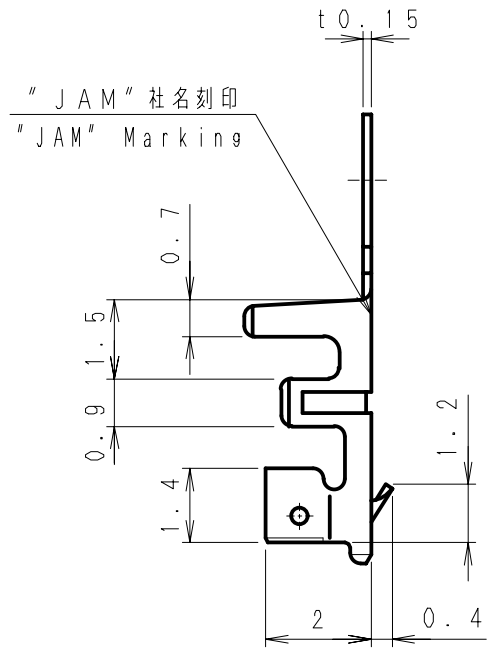
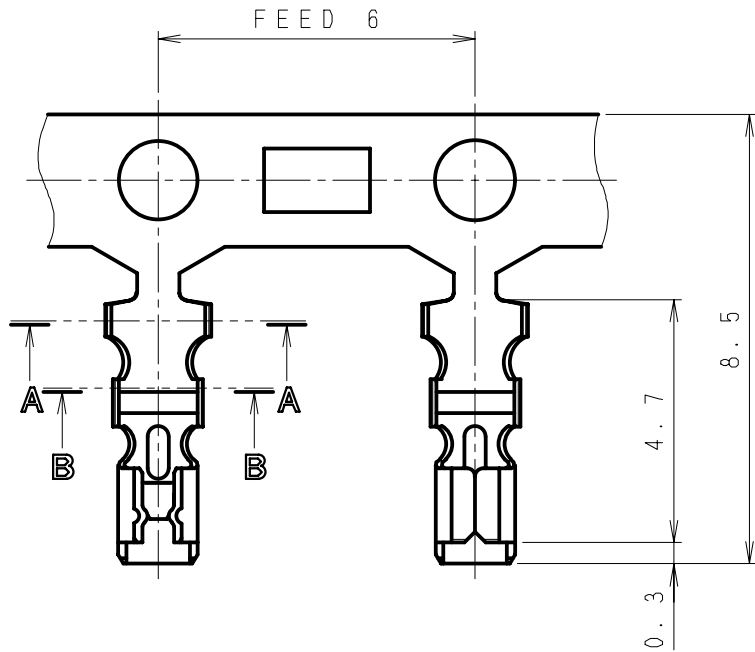

SEC A-A

SEC B-B

△6	. .								
△5	. .								
△4	. .				720474-2MAC	リン青銅 Phosphor Bronze	スズメッキ材 Pre-tin Plated	AWG#22~#24	△ φ1.1~φ1.6
△3	. .				製品番号 PRODUCT No.	材 料 MATERIAL	表面処理 FINISH	適用電線 WIRE SIZE	被覆外径 INSULATION DIA
△2	. .								
△1	05.12.12	被覆外径変更(範囲指定)	清水	堀内					
記号 No.	年月日 DATE	変更記事 REVISION RECORD	設計 DESIGN	承認 APP	製品名 NAME		ターミナル Terminal		
承認 APPROVED Y. Horiuchi		確認 CHECKED K. Kusano		一般公差 TOLERANCE ±0.3	尺度 SCALE 7/1	図番 DRAWING No. JC-0810-15Z			
設計 DESIGN K. Yokoyama		製図 DRAWING K. Yokoyama		 JAPAN AUTOMATIC MACHINE CO., LTD.					

第三角法
3rd ANGLE PROJECTION

単位：mm 注) 図面を実測しないこと
UNIT : mm NOTES) DO NOT SCALE

図番 DRAWING No.
JC-1079-18

SJH スタンプ (S-type)

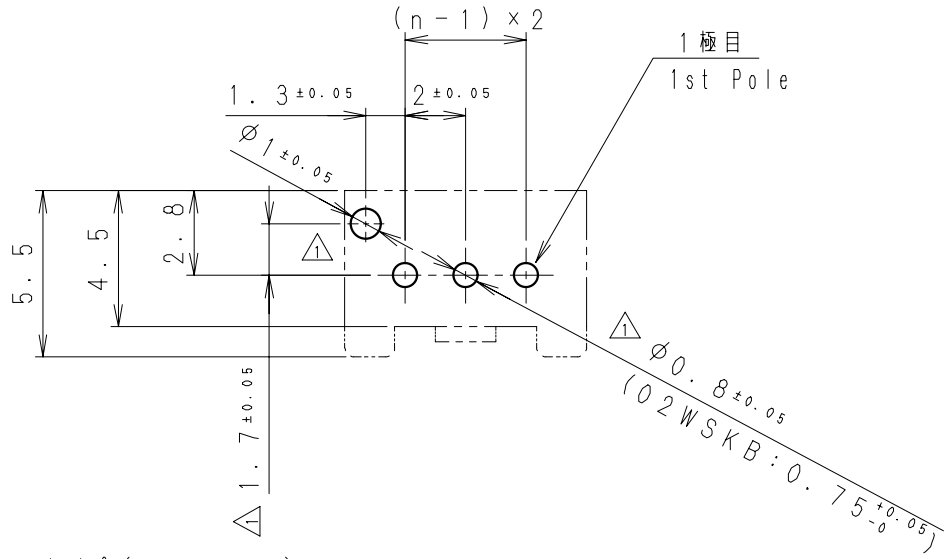

SJH Lタイプ (L-type)

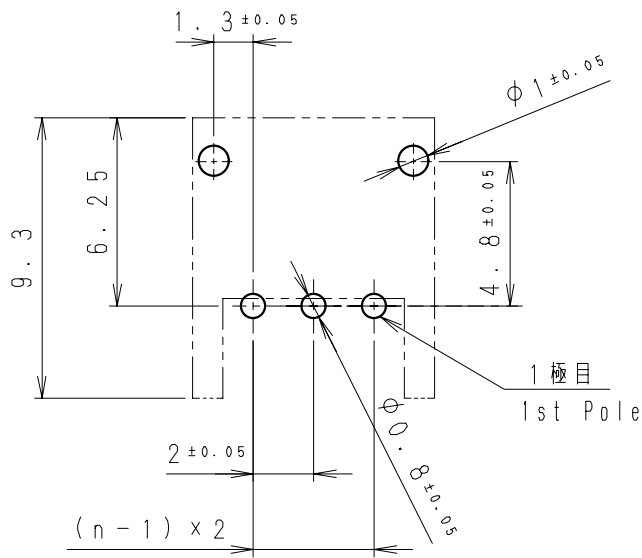

※コネクタ取付け面から表示しています。
Display from connector installation side.

△6	. .								
△5	. .								
△4	. .								
△3	. .								
△2	. .								
△1	10. 5. 24	形状変更、アイテム追加 Form change, Item add.	熊倉	草野	製品番号 PRODUCT No.	No.	材 料 MATERIAL	備考 NOTE	色 COLOR
記号 No.	年月日 DATE	変更記事 REVISION RECORD	設計 DESIGN	承認 APP	製品名 NAME		SJHウエハー 基板レイアウト (ボス) SJH Wafer P.C.B. Layout (with boss)		
承認 APPROVED	確認 CHECKED		一般公差 TOLERANCE		尺度 SCALE	図番 DRAWING No.			
K. Kusano	K. Koizumi		± 0.3		4 / 1	JC-1079-18			
設計 DESIGN	製図 DRAWING								
A. Kumakura	Y. Shimizu								