

御中

製品仕様書
Product specifications

製品名 Product Name	SJHコネクタ (SMTタイプ) 耐熱性向上タイプ SJH connector (SMT-Type) Increased heat resistant resin type	
	ターミナル Terminal	720374-2MAC 720474-2MAC
製品番号 Product Number	ハウジング Housing	SJH2K-□□HG※※
	ウエハー Wafer	SJH2K-□□WV※※ SJH2K-□□WH※※

受領印欄

Acknowledged

日本オートマチックマシン株式会社
電子部品事業部 製品技術G
〒146-0092 東京都大田区下丸子3-28-4
TEL 03(3756)1435
JAPAN AUTOMATIC MACHINE CO.,LTD
Product Engineering Group Electronic Parts
Headquarters
3-28-4, Shimomaruko, Ota-ku, Tokyo 146-0092, Japan

※ RoHS対応品
This product corresponds to RoHS.

<変更履歴表> ALTERATION HISTORY RECORDS

履歴 Revision	日付 Date	変更内容 Contents of Alteration	変 更 Change	承 認 Approved
制定 Issue	2019. 8. 8	—	大垣	小泉
△				
△				
△				
△				
△				
△				
△				
△				
△				

<目次> INDEX

1. 適用範囲 (Scope)
2. 製品名・製品番号 (Product name and number)
3. 形状・寸法・材料 (Geometry and materials)
4. 定格 (Rated values)
5. 性能 (Performances)
6. 梱包・表示 (Packing and marking)
7. 梱包数量 (Packing Quantity)
8. 品番構成 (Product No. code)

仕様書 Specifications

SA-1380S16-A0-3/18

1. 適用範囲 (Scope)

この製品仕様書は「S J Hコネクタ」の一般仕様及び性能について規定する。
The present document concerns general specifications and performances of "SJH connector".

2. 製品名・製品番号 (Product name and number)

製品名 Product Name	製品番号 Number	材料及び表面処理 Material and surface treatment
ターミナル Terminal	7 2 0 3 7 4 - 2 M A C	リン青銅 スズメッキ材 Phosphor bronze , pre-tin plated
	7 2 0 4 7 4 - 2 M A C	
ハウジング Housing	S J H 2 K - □ □ H G ※ ※	ナイロン 6 6 (UL94V-0) Nylon 66 (UL94V-0)
ウエハー(ストレート型) Wafer, Straight	S J H 2 K - □ □ W V ※ ※	ベース：ナイロン 6 T (UL94V-0) G F 入り タブコンタクト：黄銅 (スズ銅メッキ) 補強タブ：黄銅 (スズ銅メッキ)
ウエハー(アングル型) Wafer, Angle	S J H 2 K - □ □ W H ※ ※	Base: nylon 6T (UL94V-0) with GF Tab contact: brass (SnCu plated) Enhancing Tab: brass (SnCu plated)
ウエハー エンボステーピング (ストレート型) Wafer, Emboss taping, Straight	S J H 2 K - □ □ W V ※ ※ - E T C	カバーテープ：P S エンボステーピング：P S リール：ボール台紙 又は P S (エコ)
ウエハー エンボステーピング (アングル型) Wafer, Emboss taping, Angle	S J H 2 K - □ □ W H ※ ※ - E T	Cover Tape: PS Emboss Tape: PS Reel: Card board or PS, Eco

3. 形状・寸法・材料 (Geometry and materials)

添付図面による。

Refer to attached drawings.

図面番号 Drawing No.	製品名 Product name	記号 Mark
J C - 1 0 7 9 - 1 1 0	S J Hコネクタ Sタイプ A s s 'y SJH Connector, S-type Ass'y	2~3P 0
J C - 1 0 7 9 - 1 1 1	S J Hコネクタ Sタイプ A s s 'y SJH Connector, S-type Ass'y	4P 0
J C - 1 0 7 9 - 1 1 2	S J Hコネクタ Sタイプ A s s 'y SJH Connector, S-type Ass'y	5~7P 0
J C - 1 0 7 9 - 1 1 3	S J Hコネクタ Sタイプ A s s 'y SJH Connector, S-type Ass'y	8~15P 0
J C - 1 0 7 9 - 1 1 4	S J Hコネクタ Lタイプ A s s 'y SJH Connector, L-type Ass'y	2~3P 0
J C - 1 0 7 9 - 1 1 5	S J Hコネクタ Lタイプ A s s 'y SJH Connector, L-type Ass'y	4P 0
J C - 1 0 7 9 - 1 1 6	S J Hコネクタ Lタイプ A s s 'y SJH Connector, L-type Ass'y	5~7P 0
J C - 1 0 7 9 - 1 1 7	S J Hコネクタ Lタイプ A s s 'y SJH Connector, L-type Ass'y	8~15P 0
J C - 0 9 5 0 - 0 9 Z	S J Hハウジング SJH housing	2~3P 0
J C - 0 9 5 0 - 1 0 Z	S J Hハウジング SJH housing	4P 0
J C - 0 9 5 0 - 1 1 Z	S J Hハウジング SJH housing	5~7P 0
J C - 0 9 5 0 - 1 2 Z	S J Hハウジング SJH housing	8~16P 0
J C - 1 0 7 9 - 1 1 8	S J Hウエハー ストレート型 SJH Wafer, Straight type	2P 0
J C - 1 0 7 9 - 1 1 9	S J Hウエハー ストレート型 SJH Wafer, Straight type	3P 0
J C - 1 0 7 9 - 1 2 0	S J Hウエハー ストレート型 SJH Wafer, Straight type	4~7P 0
J C - 1 0 7 9 - 1 2 1	S J Hウエハー ストレート型 SJH Wafer, Straight type	8~15P 0
J C - 1 0 7 9 - 1 2 2	S J Hウエハー アングル型 SJH Wafer, Angle type	2P 0
J C - 1 0 7 9 - 1 2 3	S J Hウエハー アングル型 SJH Wafer, Angle type	3P 0
J C - 1 0 7 9 - 1 2 4	S J Hウエハー アングル型 SJH Wafer, Angle type	4~7P 0
J C - 1 0 7 9 - 1 2 5	S J Hウエハー アングル型 SJH Wafer, Angle type	8~15P 0

図面番号 Drawing No.	製品名 Product name	記号 Mark
J C - 1 0 7 9 - 6 2	S J H ウエハー ストレート型 エンボステーピング SJH wafer straight type, emboss taping	△
J C - 1 0 7 9 - 6 3	S J H ウエハー アングル型 エンボステーピング SJH wafer angle type, emboss taping	△
J C - 0 8 1 0 - 3 7 Z	S J H ウエハー用カバー Cover for SJH wafer	0
J C - 0 8 1 0 - 1 4 Z	ターミナル Terminal	△
J C - 0 8 1 0 - 1 5 Z	ターミナル Terminal	△
J C - 1 0 7 9 - 6 4	S J H コネクタ推奨基板レイアウト (ストレート型) SJH Connector P.C.B. Layout (straight)	0
J C - 1 0 7 9 - 6 5	S J H コネクタ推奨基板レイアウト (アングル型) SJH Connector P.C.B. Layout (Angle)	0

4. 定格 (Rated values)

項目 Item	規格値 Description	
定格電圧 Rated voltage	250 V AC, DC 250 V AC, DC	
定格電流 Rated current	3 A (注1) 3 A (Note 1)	
使用温度範囲 Temperature range	-40 ~ +85°C (通電による温度上昇分を含む) -40 to +85°C (heating by energization included)	
適用電線範囲 (注2) Wire size (Note 2)	720474	AWG #22 ~ #24 被覆外径 φ1.1 ~ 1.6 mm AWG #22 to #24 Diameter of insulation covering φ1.1 to φ1.6 mm
	720374	AWG #24 ~ #30 被覆外径 φ0.8 ~ 1.5 mm AWG #24 to #30 Diameter of insulation covering φ0.8 to φ1.5 mm
適用プリント基板 Applicable P.C. board	厚さ: 0.8 ~ 1.6 mm Thickness 0.8 to 1.6 mm	
保存温度 Storage temperature	-30 ~ +60°C (90%RH以下) -30 to +60°C (90% RH or less)	

(注1) 定格電流はターミナル接触部の定格値であり、実使用においては使用電線の定格電流、使用温度により決定される。

(Note 1) The rated current shown is at the terminal contact section. Practically, it varies depending on rated current of particular wire and operating temperature.

(注2) 電線はより線を使用し、単線等の特殊電線は原則として使用出来ません。

(Note 2) Use a stranded wire. Do not use solid or other special wires.

5. 性能 (Performances)

性能は、下表に示す試験条件及び方法で試験を実施したとき、各項目に規定する規格値を満足すること。尚、試験は特に指定のない限り JIS C 60068-1 [環境試験方法 (電気、電子)通則] に規定された試験場所の標準にて実施する。

The performances tested under the conditions and methods given in the table below shall conform to the respective specifications. Unless otherwise specified, carry out the tests according to the standards of a place of test stipulated in IEC C 60068-1 "General Rules of Environmental Testing Method (Electric and Electronic)".

5-1 外観 (Appearance)

No.	項目 Item	規格値 Description	条件 Check
5-1-1	外観 Appearance	使用上有害となる様な割れ・変形等が無いこと Crack, deformation, etc. harmful in use are not allowed	目視 Visual

5-2 機械的性能 (Mechanical properties)

No.	項目 Item	規格値 Description	試験条件及び方法 Check
5-2-1	挿入力 Insertion force	別表A参照 See Appended Table A	ウエハーへのハウジング挿入力を、測定する。 試験速度 25mm/min Measure the force required for inserting the wafer into housing at 25mm/min.
5-2-2	保持力 Pull-out force	別表A参照 See Appended Table A	ハウジングロックを除去してウエハーとの保持力を測定する。 試験速度 100mm/min Unlock the housing, and measure the pull-out force of wafer at 100mm/min
5-2-3	ハウジングロック保持力 Housing locking power	29.4 N以上 29.4 N or more	ウエハーとハウジングを嵌合させ、ハウジングを引張り、ロックが外れるときの力を測定する。 試験速度 100mm/min Engage the wafer and housing with each other, and pull the housing at 100 mm/min until unlocked. Take the reading at this point.

No.	項目 Item	規格値 Description		試験条件及び方法 Check
5-2-4	圧着部引張強度 Tensile strength of crimped section	電線 Wire size	強度 N 以上 Minimum strength in N	ターミナルのワイヤバレルと電線導体を圧着し、治具で固定し電線の軸方向に引っ張る。 試験速度 25mm/min Crimp the terminal's wire barrel and conductor together, fasten the altogether, and pull the wire axially at 25 mm/min.
		AWG#22	44.1	
		AWG#24	29.4	
		AWG#26	19.6	
		AWG#28	9.8	
		AWG#30	4.9	
5-2-5	ターミナル 挿入力 Terminal insertion force	6.9 N 以下 6.9 N or less		ターミナルをハウジングに挿入するのに要する力を万能試験機を用いて測定する。 試験速度 25mm/min Using universal testing machine, measure the force required for inserting the terminal into housing at 25 mm/min.
5-2-6	ターミナル 保持力 Terminal pull-out force	9.8 N 以上 9.8 N or more		ハウジングに装着したターミナルを軸方向に引っ張り、ハウジングからターミナルが離脱するときの荷重を万能試験機を用いて測定する。 試験速度 25mm/min Using universal testing machine, pull the terminal axially at 25 mm/min until it leaves the housing. Take the reading at this point.
5-2-7	ウエハー タブコンタクト 保持力 Wafer tab contact pull-out force	4.9 N 以上 4.9 N or more		ウエハーのタブコンタクトを基板装着方向に押し出す。 試験速度 25mm/min Push the wafer tab contact in P.C. board attachment direction at 25 mm/min.

5-3 電氣的性能 (Electrical characteristics)

No.	項目 Item	規格値 Description	試験条件及び方法 Check
5-3-1	接触抵抗 Contact resistance	初期 10 mΩ 以下 10 mΩ or less initially	コネクタを嵌合状態にして電気抵抗を測定し、電線抵抗を差し引いて接触抵抗とする。 試験電流 15mA (20mV以下) Engage the connector, measure the overall resistance at 15 mA and 20 mV or less and, from the reading, subtract the wire resistance. Retain the difference as contact resistance.
5-3-2	絶縁抵抗 Insulation resistance	1000 MΩ 以上 1000 MΩ or more	コネクタ外面とターミナル相互間及び隣接するターミナル間にDC500Vを印可して測定する。 Apply 500 V DC between connector housing and each of terminals, and between adjacent terminals.
5-3-3	耐電圧 Dielectric strength	AC 1000 V / 1分間 異常なきこと AC 1000V / 1min. Shall remain normal	ハウジング外面とターミナル相互間及び隣接するターミナル間にて測定する。 Apply 1000 V AC for 1 min between connector housing and each of terminals, and between adjacent terminals.
5-3-4	温度上昇 Temperature rise	30 K 以下 (適用最大電線による) 30 K or less (With thickest applicable wire)	ハウジングの全極にターミナルを装着し、嵌合させて各ターミナルを直列に接続し、最大定格電流を通電した時のターミナル部の温度上昇を測定する。 Mount the terminals on all housing poles, engage them, connect all terminals in series, apply rated current, and measure the temperature at terminals.

5-4 耐久環境性能 (Durability)

No.	項目 Item	規格値 Description		試験条件及び方法 Check
5-4-1	挿抜寿命 Engagement and disengagement	接触抵抗 Contact resistance	20mΩ 以下 20 mΩ or less	ハウジングにターミナルを装着し、ウエハーにハウジングを挿抜(30回)試験前後の接触抵抗を測定する。 Mount the terminals on housing, repeat 30 cycles of insertion and removal of housing into and from wafer, and measure the contact resistance.
		外観 Appearance	異常なきこと Shall remain normal	
5-4-2	耐振動性 Vibration	接触抵抗 Contact resistance	20mΩ 以下 20 mΩ or less	コネクタを結合し、下記条件にて振動試験実施。 掃引割合 10~55~10Hz 掃引時間 1分 最大振幅 1.5 mm 振動軸方向 X、Y、Z 振動時間 各2時間=6時間 Engage the connector, and carry out tests under following conditions. Sweep frequency 10-55-10 Hz. Sweep time 1 min. Maximum amplitude 1.5 mm. Vibration axes X, Y, Z. Vibration time 2 h each or totally 6 h.
		電流瞬断 Momentary failure	1μs 以下 1 μ sec or less	
		外観 Appearance	異常なきこと Shall remain normal	
5-4-3	耐熱性 Heating	接触抵抗 Contact resistance	20mΩ 以下 20 mΩ or less	コネクタを結合後、下記条件に放置 雰囲気温度 100 ± 5℃ 放置時間 240時間 室内で1~2時間放置後測定 Engage the connector, and keep the sample for 240 h under following conditions. Ambient temperature 100 ± 5℃. Leave the sample at the room for 1 to 2 h before check.
		外観 Appearance	異常なきこと Shall remain normal	
5-4-4	耐寒性 Cold	接触抵抗 Contact resistance	20mΩ 以下 20 mΩ or less	コネクタを結合後、下記条件に放置 雰囲気温度 -40 ± 3℃ 放置時間 240時間 室内で1~2時間放置後測定 Engage the connector, and keep the sample for 240 h under following conditions. Ambient temperature -40 ± 3℃. Leave the sample at the room for 1 to 2 h before check.
		外観 Appearance	異常なきこと Shall remain normal	

No.	項目 Item	規格値 Description		試験条件及び方法 Check
5-4-5	耐温度サイクル性 Thermal shock	接触抵抗 Contact resistance	20mΩ 以下 20 mΩ or less	コネクタを結合後、下記条件に放置 1. 低温側 -40 ± 2°C 30分 2. 室温 +25 ± 10°C 10分 3. 高温側 +85 ± 2°C 30分 4. 室温 +25 ± 10°C 10分 1～4を25サイクル行う。 Engage the connector, and subject it to 25 cycles of following sequence. 1. Low temperature -40 ± 2°C for 30 min. 2. Room temperature +25 ± 10°C within 10 min. 3. High temperature +85 ± 2°C for 30 min. 4. Room temperature +25 ± 10°C within 10 min.
		外観 Appearance	異常なきこと Shall remain normal	
5-4-6	耐湿性 Moisture	接触抵抗 Contact resistance	20mΩ 以下 20 mΩ or less	コネクタを結合後、下記条件に放置 雰囲気温度 60 ± 2°C 相対湿度 90～95% RH 放置時間 240時間 室内で1～2時間放置後測定 Engage the connector, and keep the sample for 240 h under following conditions. Ambient temperature 60 ± 2°C. Relative humidity 90 to 95%. Leave the sample at the room for 1 to 2 h before check.
		絶縁抵抗 Insulation resistance	500MΩ 以上 500 MΩ or more	
		耐電圧 Dielectric strength	AC500V/ 1分間 異常なきこと Shall remain normal at 500 V AC for 1 min	
		外観 Appearance	異常なきこと Shall remain normal	

No.	項目 Item	規格値 Description		試験条件及び方法 Check
5-4-7	耐塩水噴霧性 Salt mist	接触抵抗 Contact resistance	20mΩ 以下 20 mΩ or less	コネクタを結合後、下記条件に放置 温度 35 ± 2℃ 塩水濃度 5 ± 1% (重量比) 噴霧時間 48時間 接触抵抗測定は、水洗をし室温で乾燥させてから、1～2時間放置後測定。 Engage the connector, and keep the sample under following conditions. Temperature 35 ± 2°C. Salt concentration 5 ± 1%wt. Spray time 48 h. Then, rinse the sample, and leave it dry at room temperature for 1 to 2 h.
		外観 Appearance	異常なきこと Shall remain normal	
5-4-8	耐アンモニア性 Ammonia	接触抵抗 Contact resistance	20mΩ 以下 20 mΩ or less	コネクタを結合後、下記アンモニア水の入ったデシケータ容器中に放置 濃度 28% 温度 25℃ 容積比 25 ml / ℓ 放置時間 40分 室内で1～2時間放置後測定。 Engage the connector, and keep it in desiccator filled with following aqueous ammonia for 40 min. Concentration 28%. Temperature 25°C. Volume ratio 25 ml / ℓ Leave the sample at the room for 1 to 2 h before check.
		外観 Appearance	異常なきこと Shall remain normal	
5-4-9	耐硫化水素ガス性 Hydrogen sulfide	接触抵抗 Contact resistance	20mΩ 以下 20 mΩ or less	コネクタを結合後、下記硫化水素ガス中に放置。 濃度 3 ± 1 ppm 温度 40 ± 2℃ 放置時間 96時間 室内で1～2時間放置後測定。 Engage the connector, and keep it in hydrogen sulfide for 96 h. Density 3 ± 1 ppm. Temperature 40 ± 2°C. Leave the sample at the room for 1 to 2 h before check.
		外観 Appearance	異常なきこと Shall remain normal	

5-5 半田付性能 (Soldering characteristics)

No.	項目 Item	規格値 Description	試験条件及び方法 Check
5-5-1	半田付性 Solderability	半田面に半田がムラ無く 全体に付くこと 浸漬面積の95%以上 95% or more of dipped solder side shall be coated uniformly with solder	①リフロー炉 Reflow furnace Soldering
5-5-2	半田耐熱性 Soldering heat	機能を損なう変形・損傷 等のないこと Shall remain free from deformation, damage, etc. adversely affecting the functions	半田槽温度(Temp.) MAX 250°C 時間(Time) 5 ± 0.5 秒(s) ②半田こて Soldering iron こて先温度(Temp.) 380 ± 10°C 半田付時間(Time) 3 ⁺¹ ₋₀ 秒(s)

6. 梱包・表示 (Packing and marking)

6-1 ターミナル (Terminals)

ターミナルはリールに巻き、さらにダンボール箱に梱包して出荷。
表示はリールに型番、数量、ロットNo. を明記したラベルを貼り付ける。

Wind the terminals on reel, and pack it in cardboard case for shipment.
As indications, attach a label filled with product number, quantity and lot No. onto reel.

6-2ハウジング (Housings)

ナイロン袋に入れ、さらに、ダンボール箱に梱包して出荷。
表示はナイロン袋、ダンボール箱に型番、数量、ロットNo. を明記したラベルを貼り付ける。

Put the housings in nylon bag, and pack it in cardboard case for shipment.
As indications, attach labels filled with product number, quantity and lot No. onto nylon bag and cardboard case.

6-3 ウエハー (Wafers)

(1) エンボス加工したキャリアテープに、コネクタを1個ずつ所定の状態に詰め、
カバーテープを重ねてシールする。

After embossing, the connectors shall be packed to the carrier tape one by one, and then heat-seal it by piling up the cover tapes.

※ この時、コネクタ装着部における空部の数は2個以下トシ連続して空部があつてはならない。

The empty part number of carrier tape must be 2 or less, and 2 empty parts must not be continuous.





(2) 熱シール後、リールに所定の数量を巻き取り、カバーテープの末端を粘着テープでリールのフランジに止める。

After heat sealing, it shall be winded into reel in fixed quantity, the end of cover tape shall be stucked on the reel flange by tape.

(3) 巻き取ったリールは所定の数量をナイロン袋内にシリカゲルを入れた状態で、段ボール箱に入れ梱包する。表示は、段ボール箱に型番、数量、ロットNo. を明記したラベルを貼り付ける。

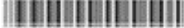
The reel put in the bag that silica gel entered shall be packed into carton in fixed quantity. Label on which product No. quantity and lot No. must be marked shall be stucked on reel box.

・ラベル (Label)

	
CATALOG No.	
①	
 	
LOT No.	QUANTITY
②	③
	
NOTE	JOINT
	0 1 2
	【RoHS】
④ MADE IN JAPAN	

① 製品番号 (Product No.)

② ロット番号 (Lot No.)

0 □ 1 L 1 8 1 0 0 1

通し番号 The through number

型番 Part No.

日付 Date (1日 1st 01...30日 30th 30)

月 Month (1月 Jan. A...12月 Dec. L)

年 Year (西暦末尾 The end of A.D)

生産工場 Production factory ※

変化点 Revision

※ 生産工場：

A：日本オートマチックマシン（株） 端子事業所（福島県 南相馬市）

Production factory：

A：JAPAN AUTOMATIC MACHINE CO.,LTD TANSHI PLANT (Minamisoma, Fukushima)

③ 数量 (Quantity)

④ 原産国 (Country of origin)：日本 (Japan)

7. 梱包数量 (Packing Quantity)

7-1 ターミナル (Terminal)

製品番号 Product number	1リール数量 Pieces /Reel	1箱リール数 Reels/1 Box	1箱数量 Pieces/Box
720374-2MAC	15,000	6	90,000
720474-2MAC	15,000	6	90,000

7-2 ハウジング (Housing)

製品番号 Product number	1袋数量 Pieces/bag	1箱袋数 Bags/Box	内箱投入数 Number of inner box	1箱数量 Pieces/Box
SJH2K-02HG	1,000	10	6	60,000
SJH2K-03HG	1,000	9	6	54,000
SJH2K-04HG	1,000	8	6	48,000
SJH2K-05HG	1,000	6	6	36,000
SJH2K-06HG	1,000	5	6	30,000
SJH2K-07HG	1,000	5	6	30,000
SJH2K-08HG	1,000	4	6	24,000
SJH2K-09HG	1,000	4	6	24,000
SJH2K-10HG	1,000	12	2	24,000
SJH2K-11HG	1,000	11	2	22,000
SJH2K-12HG	1,000	10	2	20,000
SJH2K-13HG	1,000	9	2	18,000
SJH2K-14HG	1,000	8	2	16,000
SJH2K-15HG	1,000	7	2	14,000
SJH2K-16HG	1,000	7	2	14,000

7-3 ウエハー ストレート型 (Wafer straight type)

製品番号 Product number	1リール数量 Pieces/Reel	1箱リール数 Reel/Box	1箱数量 Pieces/Box
SJH2K-02WV-ETC	1,000	10	10,000
SJH2K-03WV-ETC	1,000	10	10,000
SJH2K-03WV-ETC	1,000	10	10,000
SJH2K-04WV-ETC	1,000	7	7,000
SJH2K-05WV-ETC	1,000	7	7,000
SJH2K-06WV-ETC	1,000	7	7,000
SJH2K-07WV-ETC	1,000	7	7,000
SJH2K-08WV-ETC	1,000	7	7,000
SJH2K-09WV-ETC	1,000	7	7,000
SJH2K-10WV-ETC	1,000	7	7,000
SJH2K-11WV-ETC	1,000	7	6,000
SJH2K-12WV-ETC	1,000	7	6,000
SJH2K-13WV-ETC	1,000	7	6,000
SJH2K-14WV-ETC	1,000	7	6,000
SJH2K-15WV-ETC	1,000	7	6,000

7-3 ウエハー アングル型 (Wafer Angle type)

製品番号 Product number	1リール数量 Pieces/Reel	1箱リール数 Reel/Box	1箱数量 Pieces/Box
SJH2K-02WH-ET	1,200	10	12,000
SJH2K-03WH-ET	1,200	10	12,000
SJH2K-03WH-ET	1,200	10	12,000
SJH2K-04WH-ET	1,200	7	8,400
SJH2K-05WH-ET	1,200	7	8,400
SJH2K-06WH-ET	1,200	7	8,400
SJH2K-07WH-ET	1,200	7	8,400
SJH2K-08WH-ET	1,200	7	8,400
SJH2K-09WH-ET	1,200	7	8,400
SJH2K-10WH-ET	1,200	7	8,400
SJH2K-11WH-ET	1,200	6	7,200
SJH2K-12WH-ET	1,200	6	7,200
SJH2K-13WH-ET	1,200	6	7,200
SJH2K-14WH-ET	1,200	6	7,200
SJH2K-15WH-ET	1,200	6	7,200

8. 品番構成 (Product No. code)

<ターミナル> <Terminal>

7 2 0 □ 7 4 - 2 M A C

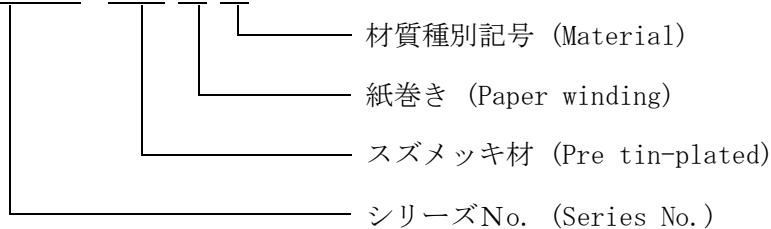

<ハウジング> <Housing>

S J H 2 K - □ □ H G ※※

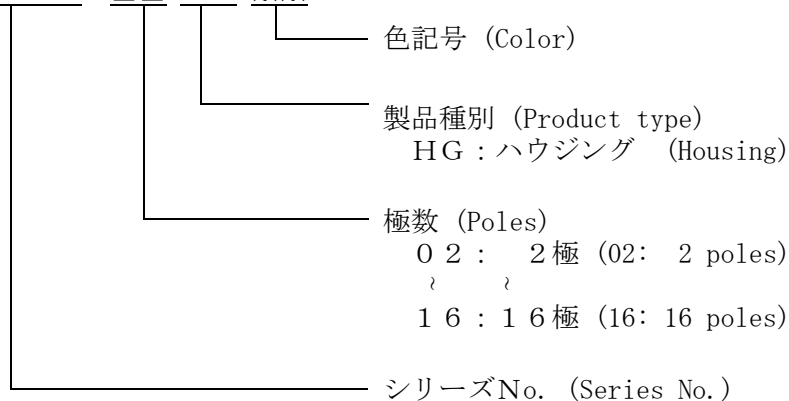

<ウエハー> <Wafer>

S J H 2 K - □ □ ○ ○ ※ ※ - E T □

カバー (Cover)
 ストレート型ウエハーのみ
 (Straight wafer only)
 E T : カバー無 (Without cover)
 E T C : カバー有 (With cover)

エンボステーピング (Emboss taping)

色記号 (Color)

製品種別 (Product type)
 W V : ウエハー ストレート型
 (WV: Wafer, straight)
 W H : ウエハー アングル型
 (WH: Wafer angle)

極数 (Poles)
 0 2 : 2 極 (02: 2 poles)
 }
 }
 1 5 : 1 5 極 (15: 15 poles)

シリーズ名 (Series No.)

<色記号> <Color>

記号 Symbol	無 None	R E	P K	G Y	Y G	B L	B K	C Y
色 Name	白 White	赤 Red	桃 Pink	灰 Gray	若草 Yellowish green	青 Blue	黒 Black	水色 Cyan

※1 J A Mでの標準色は白色です。

The standard color in JAM is white.

※2 ウエハーは成型材料がハウジングと異なるため、ハウジングとの色合いが異なってきます。ご使用時には現物での確認をお願いします。

As for wafer and housing, because the material is different, the color tone is different. Confirm it in kind at the time of the use.

【表A】挿入力及び引抜力

(Table A: Insertion force and pull-out force)

極数 Poles	挿入力(N以下) Maximum insertion force in N	保持力(N以上) Minimum pull-out force in N
2P	14.7	0.98
3P	19.6	1.47
4P	24.5	1.96
5P	29.4	2.45
6P	34.3	2.94
7P	39.2	3.43
8P	44.1	3.92
9P	49.0	4.41
10P	53.9	4.90
11P	58.8	5.39
12P	63.7	5.88
13P	68.6	6.37
14P	73.5	6.86
15P	78.4	7.35

第三角法
3rd ANGLE PROJECTION

単位：mm
UNIT: mm

注) 図面を実測しないこと
NOTES) DO NOT SCALE

図番 DRAWING No.
JC-1079-110

Poles	A	B	C
2	6.0	8.4	2.0
3	8.0	10.4	4.0

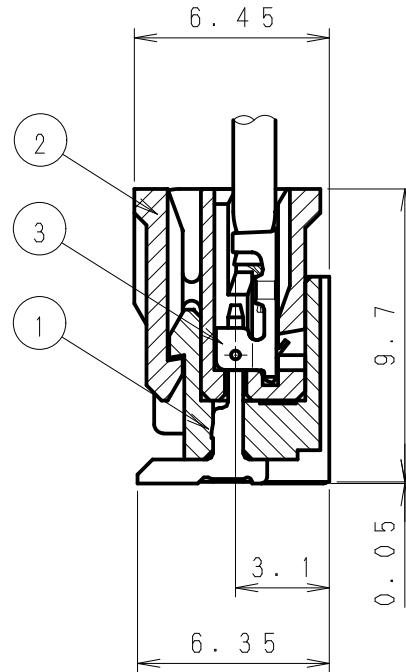
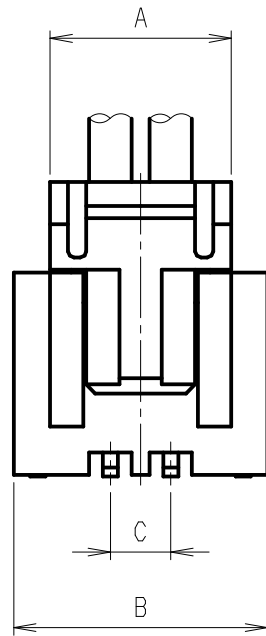

No.	製品番号 PRODUCT NO.	製品名 PRODUCT NAME	材質 MATERIAL
①	SJH2K-□□WV	ウェハー Wafer	ナイロン6T (UL94V-0) GF入り Nylon6T (UL94V-0) With GF 黄銅 (スズ銅メッキ) Brass (SnCu Plated)
②	SJH2K-□□HG	ハウジング Housing	ナイロン66 (UL94V-0) Nylon66 (UL94V-0)
③	720374-2MAC	ターミナル Terminal	リン青銅 (スズメッキ材) Phosphor Bronze (Pre-tin Plated)
	720474-2MAC		

極数	2~3	
適用電線	720474	AWG#22~#24
	720374	AWG#24~#30
被覆外径	720474	φ1.1~φ1.6mm
	720374	φ0.8~φ1.5mm

△6	. .								
△5	. .								
△4	. .								
△3	. .								
△2	. .				製品番号 PRODUCT No.	No.	材料 MATERIAL	備考 NOTE	色 COLOR
△1	. .								
記号 No.	年月日 DATE	変更記事 REVISION RECORD	設計 DESIGN	承認 APP	製品名 SJHコネクタ (ストレート型) NAME SJH Connector (Straight type)				
承認 APPROVED	確認 CHECKED		一般公差 TOLERANCE		尺度 SCALE	図番 DRAWING No.			
K. Koizumi	A. Kumakura		±0.3		4 / 1	JC-1079-110			
設計 DESIGN	製図 DRAWING								
A. Kumakura	N. Ogaki								

第三角法
3rd ANGLE PROJECTION

単位: mm
UNIT: mm

注) 図面を実測しないこと
NOTES) DO NOT SCALE

図番 DRAWING No.
JC-1079-111

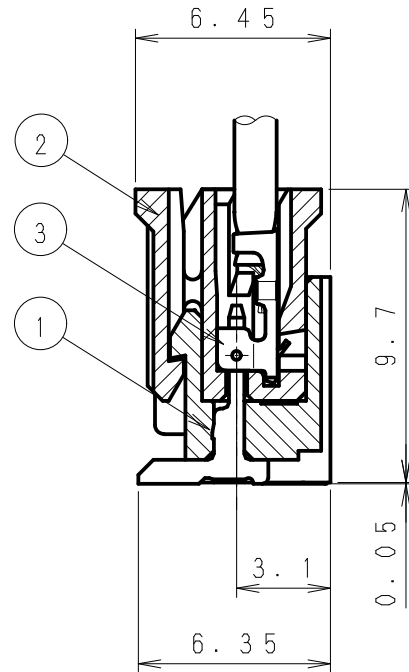
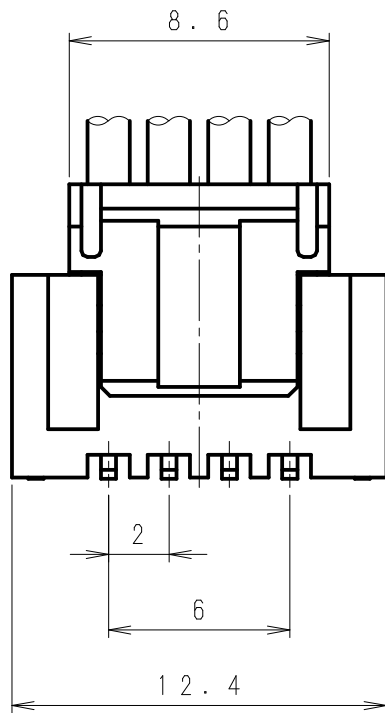

No.	製品番号 PRODUCT NO.	製品名 PRODUCT NAME	材質 MATERIAL
①	SJH2K-04WV	ウエハー Wafer	ナイロン6T (UL94V-0) GF入り Nylon6T (UL94V-0) With GF 黄銅 (スズ銅メッキ) Brass (SnCu Plated)
②	SJH2K-04HG	ハウジング Housing	ナイロン66 (UL94V-0) Nylon66 (UL94V-0)
③	720374-2MAC 720474-2MAC	ターミナル Terminal	リン青銅 (スズメッキ材) Phosphor Bronze (Pre-tin Plated)

極数	4	
適用電線	720474	AWG#22~#24
	720374	AWG#24~#30
被覆外径	720474	φ1.1~φ1.6mm
	720374	φ0.8~φ1.5mm

△6	. .								
△5	. .								
△4	. .								
△3	. .								
△2	. .				製品番号 PRODUCT No.	No.	材 料 MATERIAL	備考 NOTE	色 COLOR
△1	. .								
記号 No.	年月日 DATE	変更記事 REVISION RECORD	設計 DESIGN	承認 APP	製品名 SJHコネクタ (ストレート型) NAME SJH Connector (Straight type)				
承認 APPROVED	確認 CHECKED		一般公差 TOLERANCE		尺度 SCALE	図番 DRAWING No.			
K. Koizumi	A. Kumakura		±0.3		4 / 1	JC-1079-111			
設計 DESIGN	製図 DRAWING		JAPAN AUTOMATIC MACHINE CO., LTD.						
A. Kumakura	N. Ogaki								

Poles	A	B	C
5	10.6	14.4	8.0
6	12.6	16.4	10.0
7	14.6	18.4	12.0

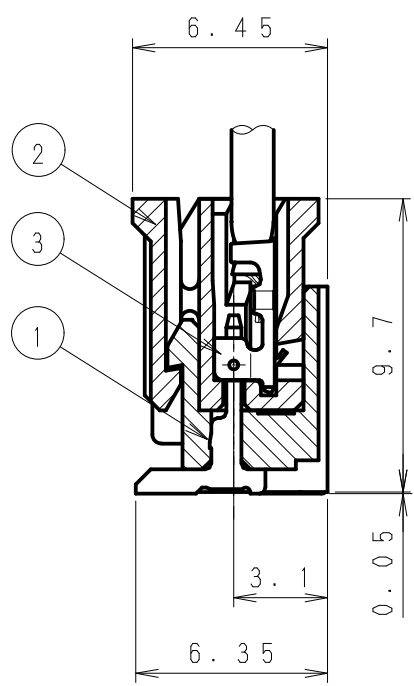
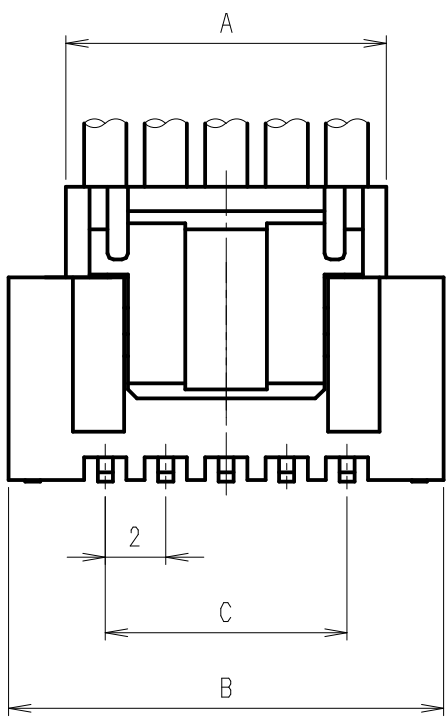

No.	製品番号 PRODUCT NO.	製品名 PRODUCT NAME	材質 MATERIAL
①	SJH2K-□□WV	ウエハー Wafer	ナイロン6T (UL94V-0) GF入り Nylon6T (UL94V-0) With GF 黄銅 (スズ銅メッキ) Brass (SnCu Plated)
②	SJH2K-□□HG	ハウジング Housing	ナイロン66 (UL94V-0) Nylon66 (UL94V-0)
③	720374-2MAC 720474-2MAC	ターミナル Terminal	リン青銅 (スズメッキ材) Phosphor Bronze (Pre-tin Plated)

極 数	5 ~ 7	
適用電線	720474	AWG#22 ~ #24
	720374	AWG#24 ~ #30
被覆外径	720474	φ1.1 ~ φ1.6mm
	720374	φ0.8 ~ φ1.5mm

△6	. .																			
△5	. .																			
△4	. .																			
△3	. .																			
△2	. .																			
△1	. .																			
記号 No.	年月日 DATE	変更記事 REVISION RECORD	設計 DESIGN	承認 APP	製品番号 PRODUCT No.	No.	材 料 MATERIAL	備考 NOTE	色 COLOR	製品名 SJHコネクタ (ストレート型) NAME SJH Connector (Straight type)										
承認 APPROVED	K. Koizumi		確認 CHECKED	A. Kumakura		一般公差 TOLERANCE	±0.3	尺度 SCALE	4 / 1	図番 DRAWING No.	JC-1079-112									
設計 DESIGN	A. Kumakura		製図 DRAWING	N. Ogaki		JAPAN AUTOMATIC MACHINE CO., LTD.														

Poles	A	B	C	Poles	A	B	C
8	16.6	20.4	14.0	12	24.6	28.4	22.0
9	18.6	22.4	16.0	13	26.6	30.4	24.0
10	20.6	24.4	18.0	14	28.6	32.4	26.0
11	22.6	26.4	20.0	15	30.6	34.4	28.0

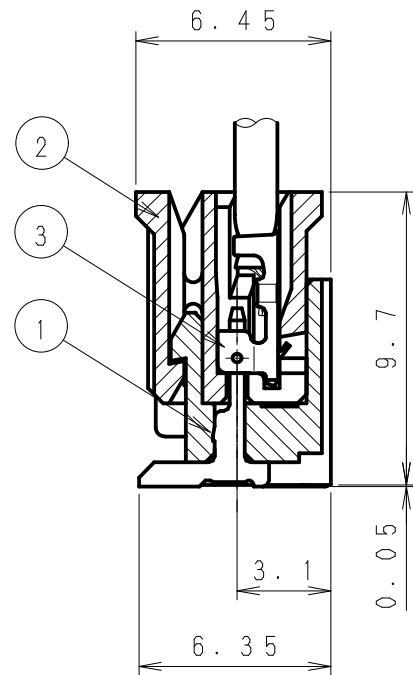
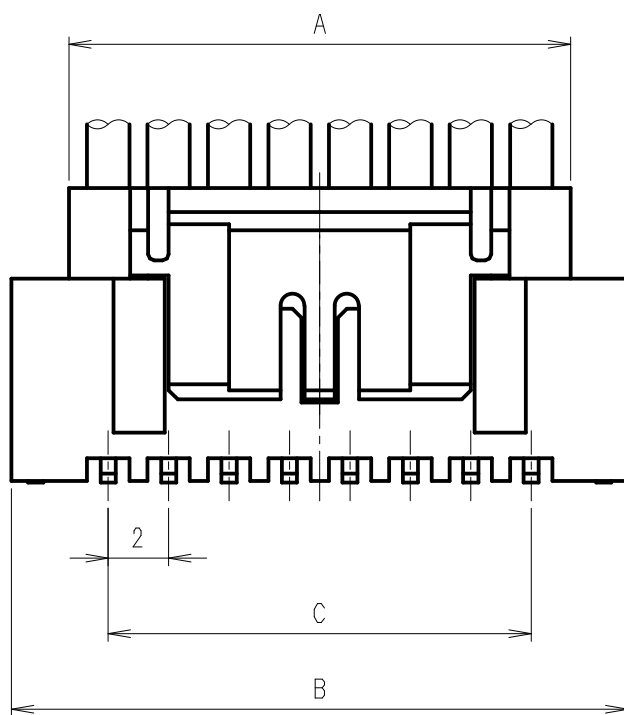

No.	製品番号 PRODUCT NO.	製品名 PRODUCT NAME	材質 MATERIAL
①	SJH2K-□□WV	ウエハ Wafer	ナイロン6T (UL94V-0) GF入り Nylon6T (UL94V-0) With GF 黄銅 (スズ銅メッキ) Brass (SnCu Plated)
②	SJH2K-□□HG	ハウジング Housing	ナイロン66 (UL94V-0) Nylon66 (UL94V-0)
③	720374-2MAC 720474-2MAC	ターミナル Terminal	リン青銅 (スズメッキ材) Phosphor Bronze (Pre-tin Plated)

極数	8 ~ 15	
適用電線	720474	AWG#22~#24
	720374	AWG#24~#30
被覆外径	720474	φ1.1~φ1.6mm
	720374	φ0.8~φ1.5mm

△6
△5
△4
△3
△2	製品番号 PRODUCT No.	No.	材 料 MATERIAL	備考 NOTE	色 COLOR
△1
記号 No.	年月日 DATE	変更記事 REVISION RECORD	設計 DESIGN	承認 APP	製品名 NAME SJH Connector (Straight type)				
承認 APPROVED	確認 CHECKED		一般公差 TOLERANCE		尺度 SCALE	図番 DRAWING No.			
K. Koizumi	A. Kumakura		±0.3		4 / 1	JC-1079-113			
設計 DESIGN	製図 DRAWING		JAPAN AUTOMATIC MACHINE CO., LTD.						
A. Kumakura	N. Ogaki								

第三角法
3rd ANGLE PROJECTION

単位：mm 注) 図面を実測しないこと
UNIT : mm NOTES) DO NOT SCALE

図番 DRAWING No.
JC-1079-114

Poles	A	B	C
2	6.0	8.4	2.0
3	8.0	10.4	4.0

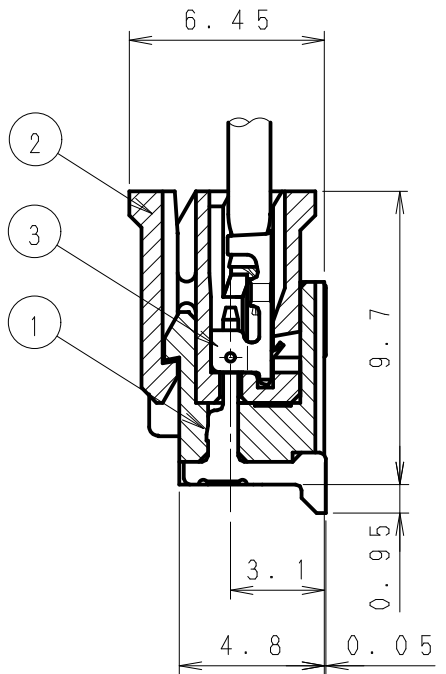
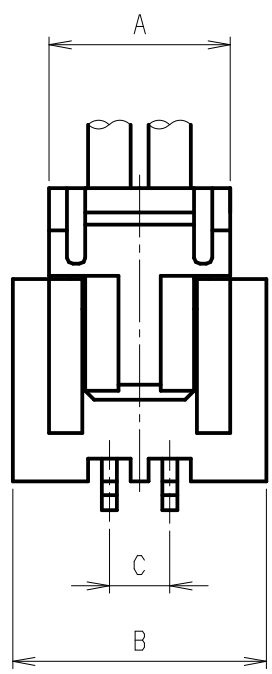

No.	製品番号 PRODUCT NO.	製品名 PRODUCT NAME	材質 MATERIAL
①	SJH2K-□□WH	ウェハー Wafer	ナイロン6T (UL94V-0) GF入り Nylon6T (UL94V-0) With GF 黄銅 (スズ銅メッキ) Brass (SnCu Plated)
②	SJH2K-□□HG	ハウジング Housing	ナイロン66 (UL94V-0) Nylon66 (UL94V-0)
③	720374-2MAC	ターミナル Terminal	リン青銅 (スズメッキ材) Phosphor Bronze (Pre-tin Plated)
	720474-2MAC		

極数	2 ~ 3	
適用電線	720474	AWG#22 ~ #24
	720374	AWG#24 ~ #30
被覆外径	720474	φ1.1 ~ φ1.6mm
	720374	φ0.8 ~ φ1.5mm

△6	. .								
△5	. .								
△4	. .								
△3	. .								
△2	. .				製品番号 PRODUCT No.	No.	材料 MATERIAL	備考 NOTE	色 COLOR
△1	. .								
記号 No.	年月日 DATE	変更記事 REVISION RECORD	設計 DESIGN	承認 APP			製品名 NAME	SJHコネクタ (アングル型) SJH Connector (Angle type)	
承認 APPROVED	K. Koizumi		確認 CHECKED	A. Kumakura		一般公差 TOLERANCE	尺度 SCALE	4 / 1	
				±0.3				図番 DRAWING No. JC-1079-114	
設計 DESIGN	A. Kumakura		製図 DRAWING	N. Ogaki		JAPAN AUTOMATIC MACHINE CO., LTD.			

第三角法
3rd ANGLE PROJECTION

単位: mm
UNIT: mm

注) 図面を実測しないこと
NOTES) DO NOT SCALE

図番 DRAWING No.
JC-1079-115

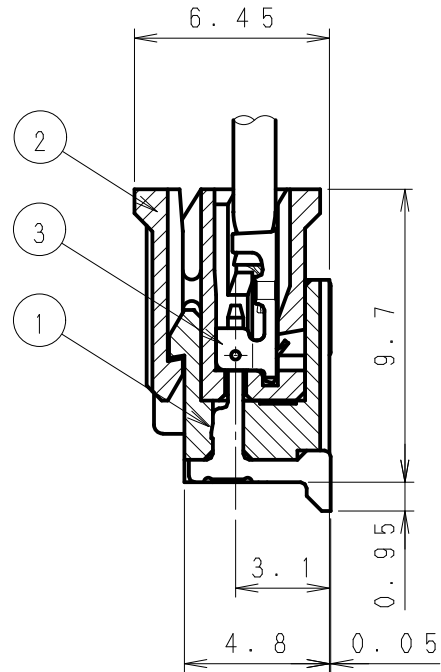
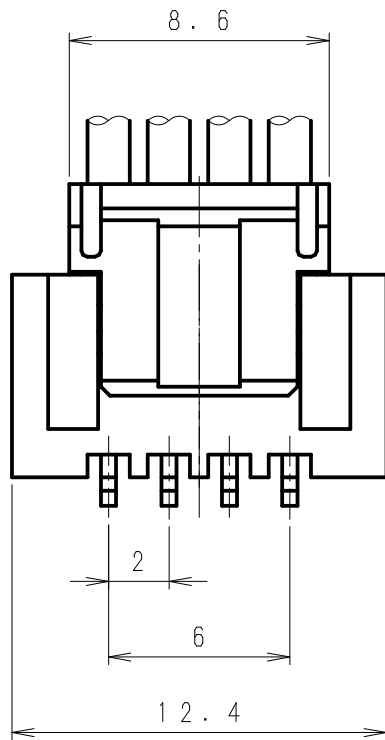

No.	製品番号 PRODUCT NO.	製品名 PRODUCT NAME	材質 MATERIAL
①	SJH2K-04WH	ウエハー Wafer	ナイロン6T (UL94V-0) GF入り Nylon6T (UL94V-0) With GF
②	SJH2K-04HG	ハウジング Housing	ナイロン66 (UL94V-0) Nylon66 (UL94V-0)
③	720374-2MAC 720474-2MAC	ターミナル Terminal	リン青銅 (スズメッキ材) Phosphor Bronze (Pre-tin Plated)

極数	4	
適用電線	720474	AWG#22~#24
	720374	AWG#24~#30
被覆外径	720474	φ1.1~φ1.6mm
	720374	φ0.8~φ1.5mm

△6	. . .								
△5	. . .								
△4	. . .								
△3	. . .								
△2	. . .				製品番号 PRODUCT No.	No.	材 料 MATERIAL	備考 NOTE	色 COLOR
△1	. . .								
記号 No.	年月日 DATE	変更記事 REVISION RECORD	設計 DESIGN	承認 APP			製品名 NAME	SJHコネクタ (アングル型) SJH Connector (Angle type)	
承認 APPROVED	K. Koizumi		確認 CHECKED	A. Kumakura		一般公差 TOLERANCE	尺度 SCALE	4 / 1	
		±0.3				図番 DRAWING No.		JC-1079-115	
設計 DESIGN	A. Kumakura		製図 DRAWING	N. Ogaki		JAPAN AUTOMATIC MACHINE CO., LTD.			

Poles	A	B	C
5	10.6	14.4	8.0
6	12.6	16.4	10.0
7	14.6	18.4	12.0

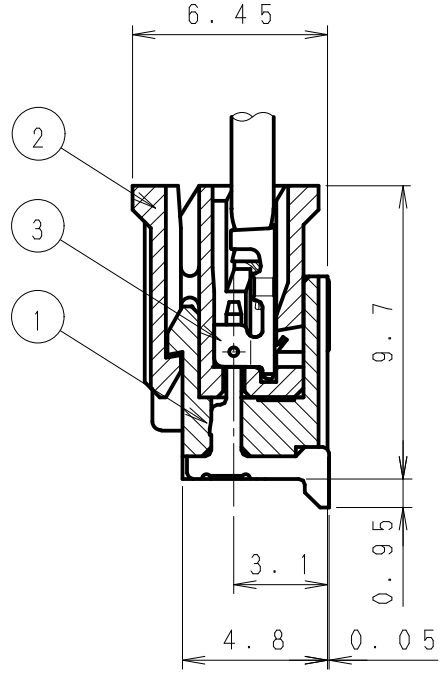
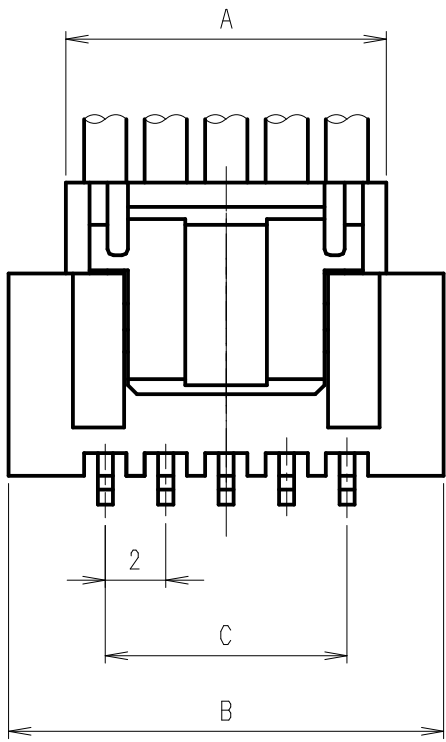

No.	製品番号 PRODUCT NO.	製品名 PRODUCT NAME	材質 MATERIAL
①	SJH2K-□□WH	ウェハー Wafer	ナイロン6T (UL94V-0) GF入り Nylon6T (UL94V-0) With GF 黄銅 (スズ銅メッキ) Brass (SnCu Plated)
②	SJH2K-□□HG	ハウジング Housing	ナイロン66 (UL94V-0) Nylon66 (UL94V-0)
③	720374-2MAC 720474-2MAC	ターミナル Terminal	リン青銅 (スズメッキ材) Phosphor Bronze (Pre-tin Plated)

極数	5~7	
適用電線	720474	AWG#22~#24
	720374	AWG#24~#30
被覆外径	720474	φ1.1~φ1.6mm
	720374	φ0.8~φ1.5mm

△6	. .								
△5	. .								
△4	. .								
△3	. .								
△2	. .				製品番号 PRODUCT No.	No.	材 料 MATERIAL	備考 NOTE	色 COLOR
△1	. .								
記号 No.	年月日 DATE	変更記事 REVISION RECORD	設計 DESIGN	承認 APP	製品名 NAME		SJHコネクタ (アングル型) SJH Connector (Angle type)		
承認 APPROVED	確認 CHECKED		一般公差 TOLERANCE		尺度 SCALE	図番 DRAWING No.			
K. Koizumi	A. Kumakura		±0.3		4 / 1	JC-1079-116			
設計 DESIGN	製図 DRAWING		JAPAN AUTOMATIC MACHINE CO., LTD.						
A. Kumakura	N. Ogaki								

Poles	A	B	C	Poles	A	B	C
8	16.6	20.4	14.0	12	24.6	28.4	22.0
9	18.6	22.4	16.0	13	26.6	30.4	24.0
10	20.6	24.4	18.0	14	28.6	32.4	26.0
11	22.6	26.4	20.0	15	30.6	34.4	28.0

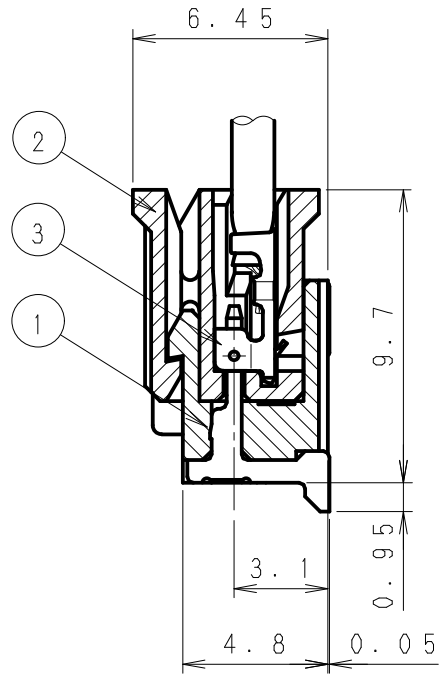
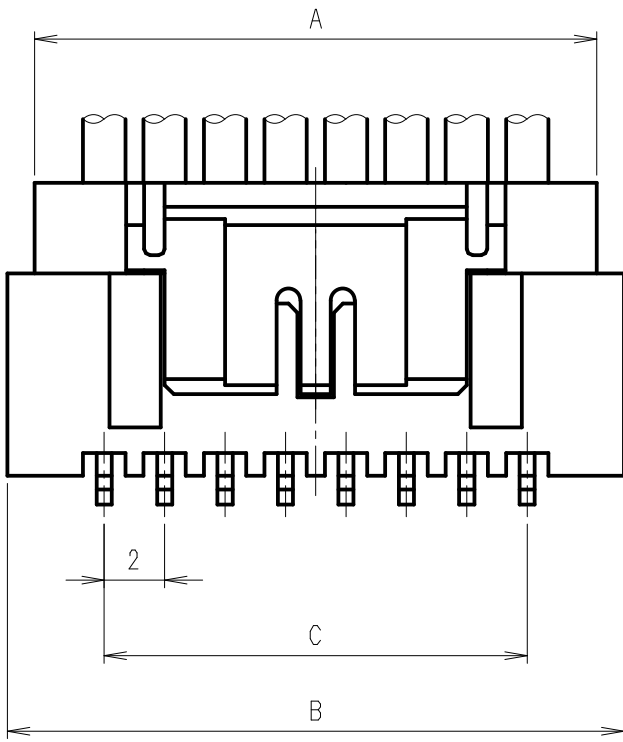

No.	製品番号 PRODUCT NO.	製品名 PRODUCT NAME	材質 MATERIAL
①	SJH2K-□□WH	ウエハー Wafer	ナイロン6T (UL94V-0) GF入り Nylon6T (UL94V-0) With GF 黄銅 (スズ銅メッキ) Brass (SnCu Plated)
②	SJH2K-□□HG	ハウジング Housing	ナイロン66 (UL94V-0) Nylon66 (UL94V-0)
③	720374-2MAC 720474-2MAC	ターミナル Terminal	リン青銅 (スズメッキ材) Phosphor Bronze (Pre-tin Plated)

極 数	8 ~ 15	
適用電線	720474	AWG#22 ~ #24
	720374	AWG#24 ~ #30
被覆外径	720474	φ1.1 ~ φ1.6mm
	720374	φ0.8 ~ φ1.5mm

△6	. . .								
△5	. . .								
△4	. . .								
△3	. . .								
△2	. . .				製品番号 PRODUCT No.	No.	材 料 MATERIAL	備考 NOTE	色 COLOR
△1	. . .								

記号 No.	年月日 DATE	変更記事 REVISION RECORD	設計 DESIGN	承認 APP	製品名 NAME	SJHコネクタ (アングル型) SJH Connector (Angle type)					
承認 APPROVED	K. Koizumi		確認 CHECKED	A. Kumakura		一般公差 TOLERANCE	尺度 SCALE	4 / 1			
±0.3		図番 DRAWING No.		JC-1079-117							
設計 DESIGN	A. Kumakura		製図 DRAWING	N. Ogaki							

第三角法
3rd ANGLE PROJECTION

単位: mm
UNIT: mm
注) 図面を実測しないこと
NOTES) DO NOT SCALE

図番 DRAWING No.
JC-0950-09Z

極番刻印
Pole No. Mark

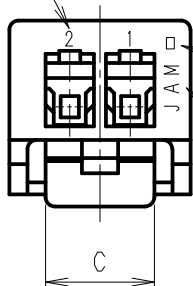

□はキャビNo刻印 (A~P)
CAV No. mark (A~P)
"JAM" 社名刻印
"JAM" Mark

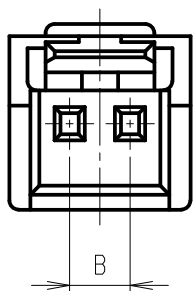
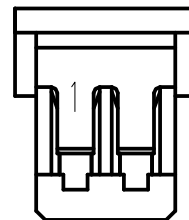
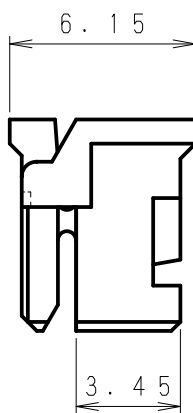
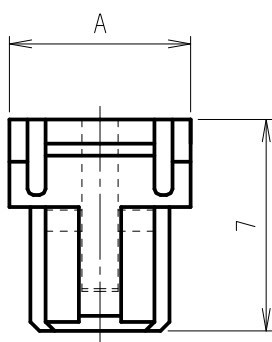

極数 Poles	A	B	C
2	6.0	2.0	3.6
3	8.0	4.0	4.4

△5	. .								
△4	. .								
△3	. .				SJH2K-□□HG		ナイロン66 Nylon66	UL94V-0	
△2	. .				製品番号 PRODUCT No.	No.	材 料 MATERIAL	備考 NOTE	
△1	. .							色 COLOR	
記号 No.	年月日 DATE	変更記事 REVISION RECORD	設計 DESIGN	承認 APP	製品名 NAME			SJHハウジング SJH Housing	
承認 APPROVED	確認 CHECKED		一般公差 TOLERANCE		尺度 SCALE	図番 DRAWING No.			
K. Kusano	A. Kumakura		±0.3		4 / 1	JC-0950-09Z			
設計 DESIGN	製図 DRAWING								
Y. Shimizu	Y. Shimizu								

第三角法
3rd ANGLE PROJECTION

単位: mm
UNIT: mm

注) 図面を実測しないこと
NOTES) DO NOT SCALE

図番 DRAWING No.
JC-0950-10Z

極番刻印
Pole No. Mark

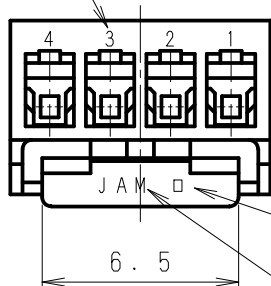

□はキャビNo刻印 (A~P)
CAV No. mark (A~P)

"JAM" 社名刻印
"JAM" Mark

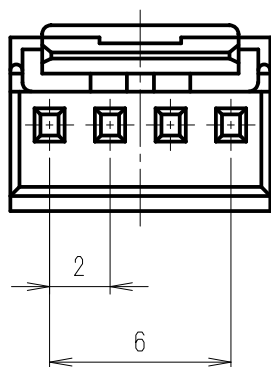
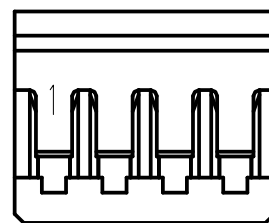
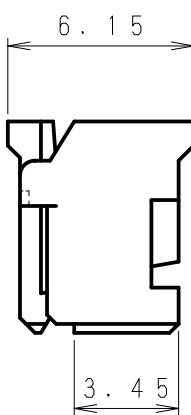
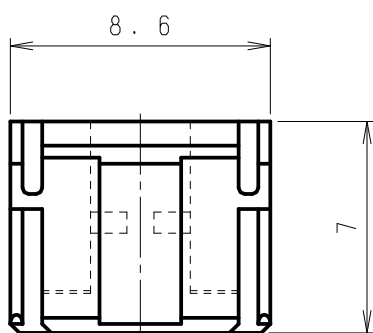

△5	. .								
△4	. .								
△3	. .				SJH2K-04HG		ナイロン66 Nylon66	UL94V-0	
△2	. .				製品番号 PRODUCT No.	No.	材 料 MATERIAL	備考 NOTE	色 COLOR
△1	. .								
記号 No.	年月日 DATE	変更記事 REVISION RECORD	設計 DESIGN	承認 APP			製品名 NAME	SJHハウジング SJH Housing	
承認 APPROVED	確認 CHECKED		一般公差 TOLERANCE		尺度 SCALE	図番 DRAWING No.			
K. Kusano	A. Kumakura		±0.3		4 / 1	JC-0950-10Z			
設計 DESIGN	製図 DRAWING								
Y. Shimizu	Y. Shimizu								

第三角法
3rd ANGLE PROJECTION

単位: mm
UNIT: mm
注) 図面を実測しないこと
NOTES) DO NOT SCALE

図番 DRAWING No.
JC-0950-11Z

極番刻印
Pole No. Mark

"JAM" 社名刻印
"JAM" Mark

□はキャビNo刻印 (A~P)
CAV No. mark (A~P)

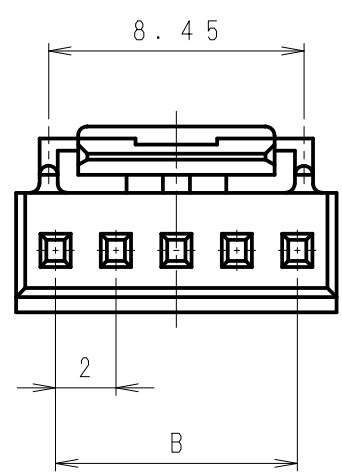
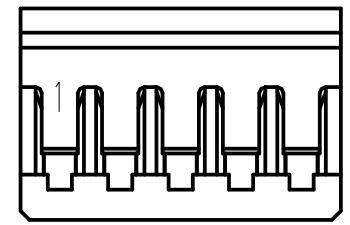
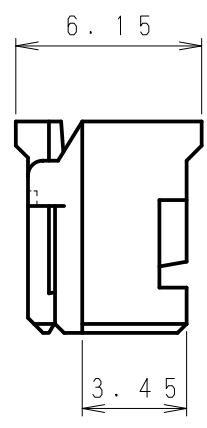
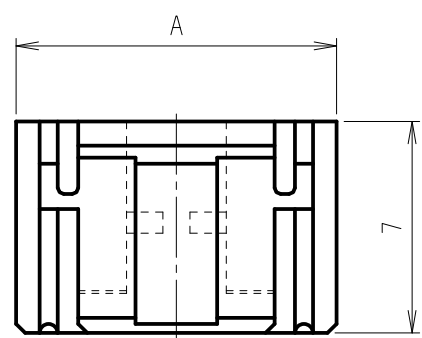
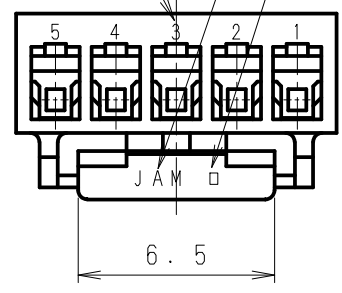

極数 Poles	A	B
5	10.6	8.0
6	12.6	10.0
7	14.6	12.0

△5	. .							
△4	. .							
△3	. .				SJH2K-□□HG		ナイロン66 Nylon66	UL94V-0
△2	. .				製品番号 PRODUCT No.	No.	材 料 MATERIAL	備考 NOTE
△1	. .							色 COLOR
記号 No.	年月日 DATE	変更記事 REVISION RECORD	設計 DESIGN	承認 APP	製品名 NAME		SJHハウジング SJH Housing	
承認 APPROVED	確認 CHECKED		一般公差 TOLERANCE		尺度 SCALE	図番 DRAWING No.		
K. Kusano	A. Kumakura		±0.3		4 / 1	JC-0950-11Z		
設計 DESIGN	製図 DRAWING		 JAPAN AUTOMATIC MACHINE CO., LTD.					
Y. Shimizu	Y. Shimizu							

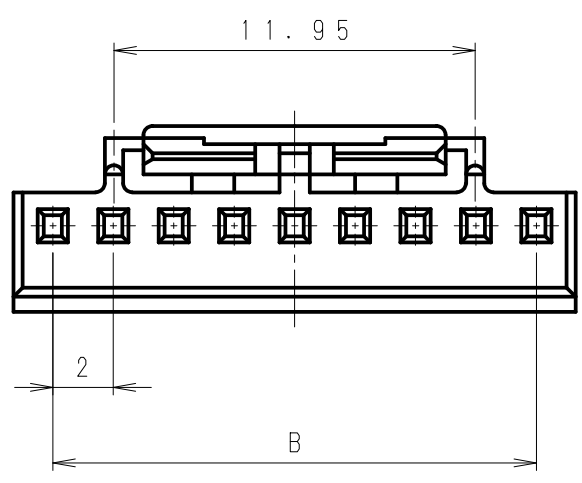
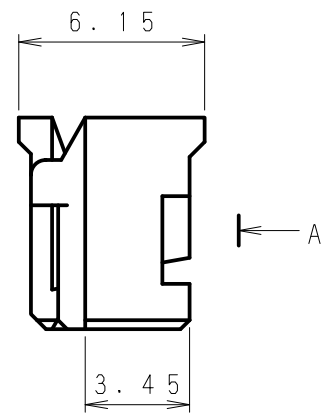
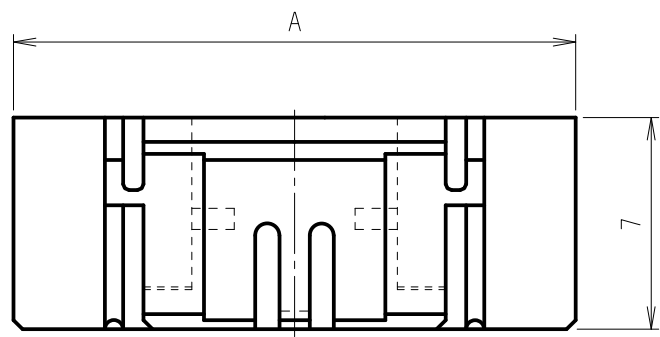
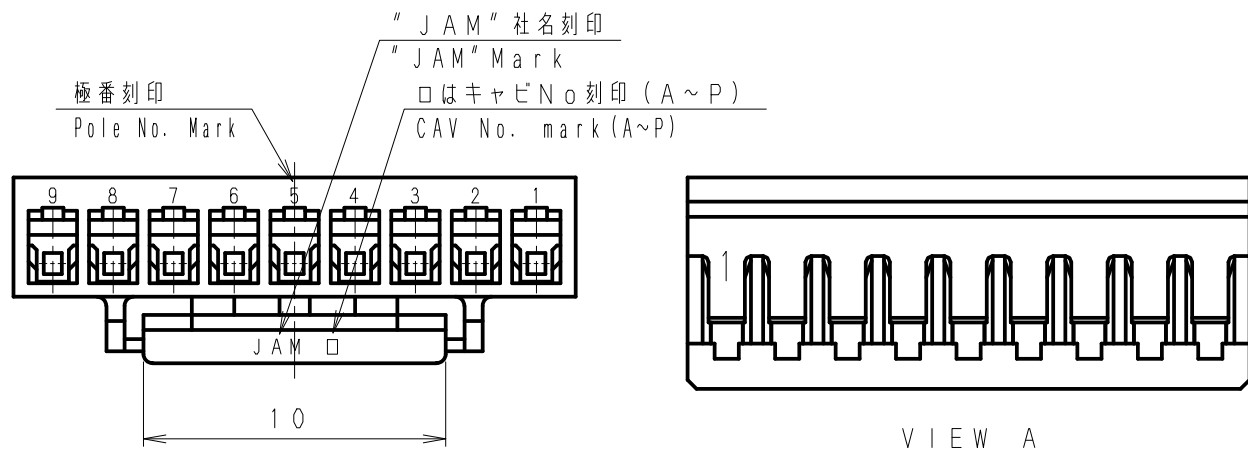

極数 Poles	A	B
8	16.6	14.0
9	18.6	16.0
10	20.6	18.0
11	22.6	20.0
12	24.6	22.0
13	26.6	24.0
14	28.6	26.0
15	30.6	28.0
16	32.6	30.0

△5	. .							
△4	. .				SJH2K-□□HG	ナイロン66 Nylon66	UL94V-0	
△3	. .				製品番号 PRODUCT No.	材 料 MATERIAL	備考 NOTE	色 COLOR
△2	. .				No.			
△1	. .							
記号 No.	年月日 DATE	変更記事 REVISION RECORD	設計 DESIGN	承認 APP	製品名 NAME		SJHハウジング SJH Housing	
承認 APPROVED	確認 CHECKED		一般公差 TOLERANCE		尺度 SCALE	図番 DRAWING No.		
K. Kusano	A. Kumakura		±0.3		4/1	JC-0950-12Z		
設計 DESIGN	製図 DRAWING		JAPAN AUTOMATIC MACHINE CO., LTD.					
Y. Shimizu	Y. Shimizu							

第三角法
3rd ANGLE PROJECTION

単位: mm 注) 図面を実測しないこと
UNIT: mm NOTES) DO NOT SCALE

図番 DRAWING No.
JC-1079-118

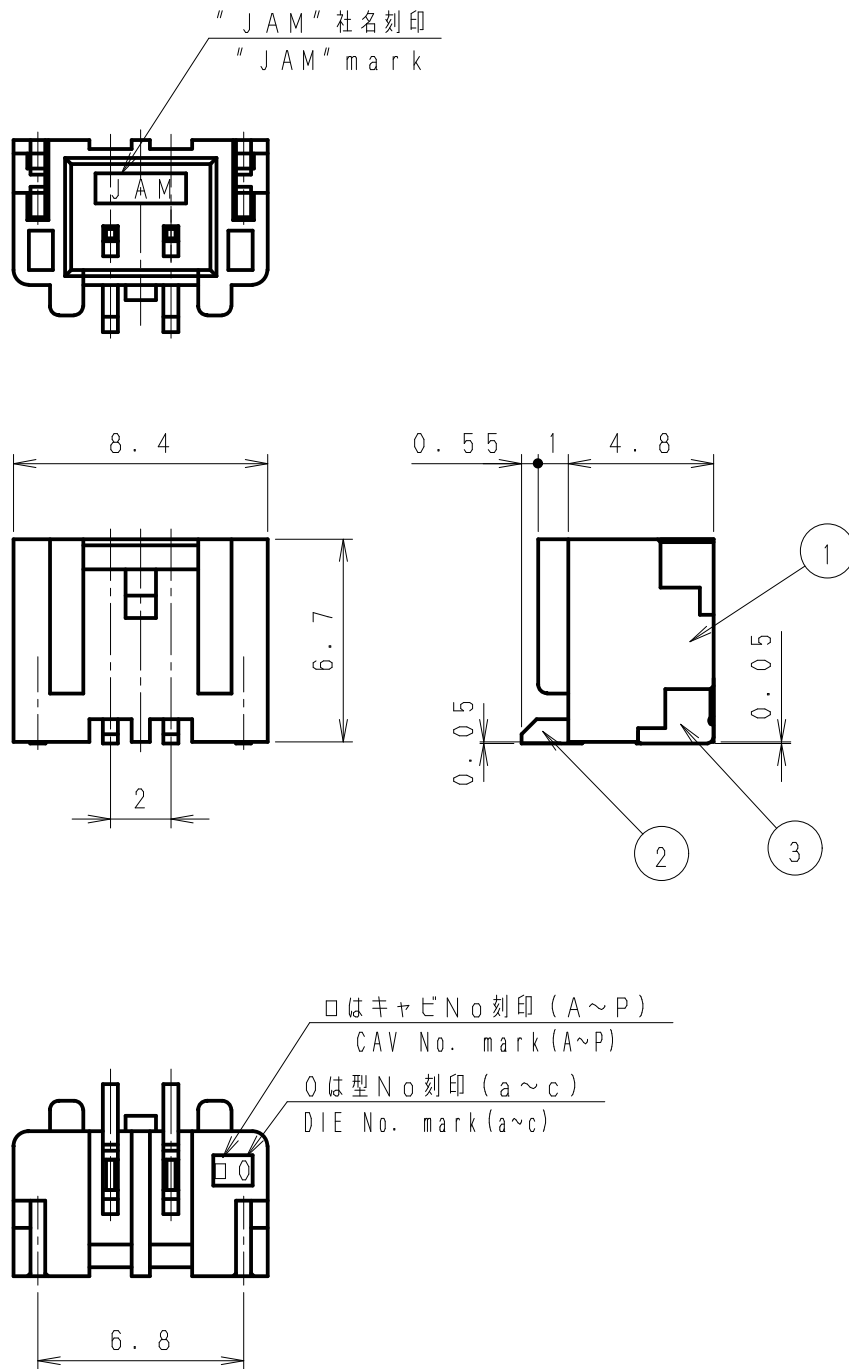

⑤	. .					③	黄銅 Brass	スズ銅メッキ SnCu-Plated		
④	. .				SJH2K-02WV	②	黄銅 Brass	スズ銅メッキ SnCu-Plated		
③	. .					①	ナイロン6T (GF入り) Nylon 6T (With GF)	UL94V-0		
②	. .				製品番号 PRODUCT No.	No.	材 料 MATERIAL	備考 NOTE	色 COLOR	
①	. .									
記号 No.	年月日 DATE	変更記事 REVISION RECORD	設計 DESIGN	承認 APP				製品名 NAME	SJHウエハー ストレート型 SJH Wafer, Straight type	
承認 APPROVED	確認 CHECKED		一般公差 TOLERANCE		尺度 SCALE	図番 DRAWING No.		JC-1079-118		
K. Koizumi		A. Kumakura		±0.3		4/1				
設計 DESIGN		製図 DRAWING								
A. Kumakura		N. Ogaki								

第三角法
3rd ANGLE PROJECTION

単位: mm 注) 図面を実測しないこと
UNIT: mm NOTES) DO NOT SCALE

図番 DRAWING No.
JC-1079-119

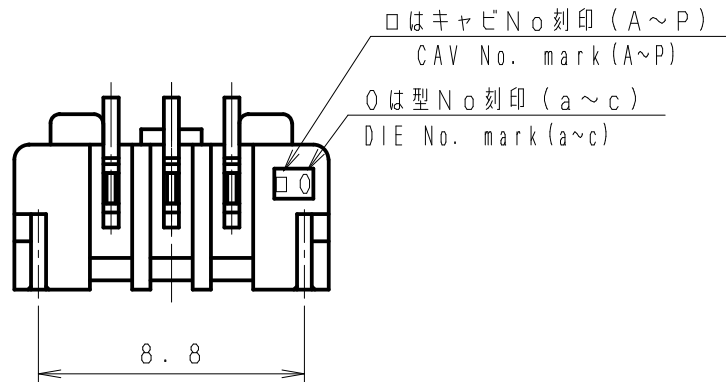
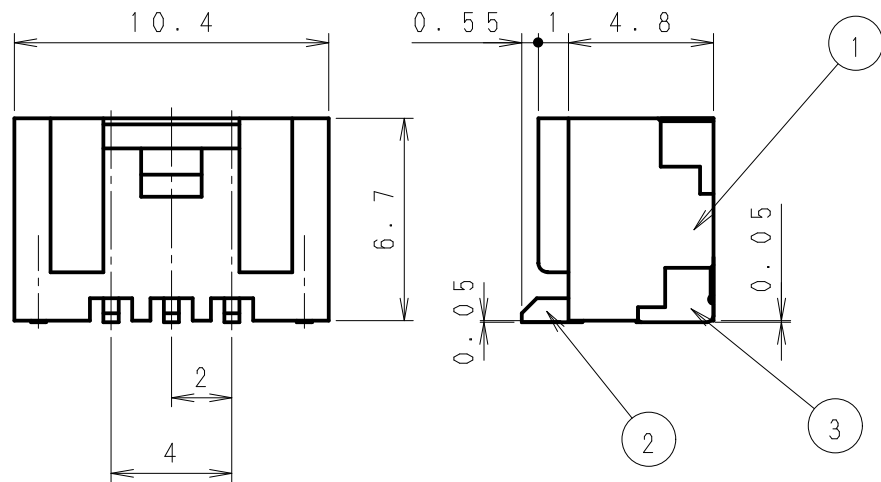
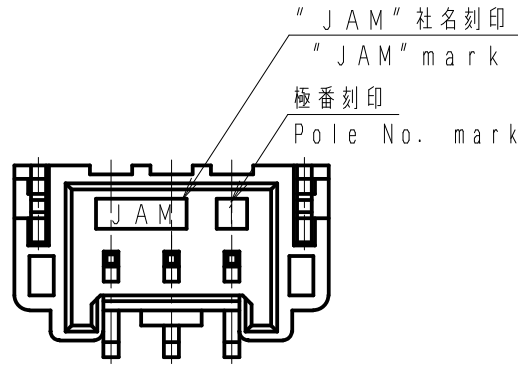

⑤	. .					③	黄銅 Brass	スズ銅メッキ SnCu-Plated	
④	. .				SJH2K-03WV	②	黄銅 Brass	スズ銅メッキ SnCu-Plated	
③	. .					①	ナイロン6T (GF入り) Nylon 6T (With GF)	UL94V-0	
②	. .				製品番号 PRODUCT No.	No.	材 料 MATERIAL	備考 NOTE	色 COLOR
①	. .								
記号 No.	年月日 DATE	変更記事 REVISION RECORD	設計 DESIGN	承認 APP	製品名 NAME		SJHウエハー ストレート型 SJH Wafer, Straight type		
承認 APPROVED	K. Koizumi	確認 CHECKED	A. Kumakura	一般公差 TOLERANCE ±0.3	尺度 SCALE 4/1	図番 DRAWING No. JC-1079-119			
設計 DESIGN	A. Kumakura	製図 DRAWING	N. Ogaki	JAPAN AUTOMATIC MACHINE CO., LTD.					

Poles	A	B	C
4	12.4	6.0	10.8
5	14.4	8.0	12.8
6	16.4	10.0	14.8
7	18.4	12.0	16.8

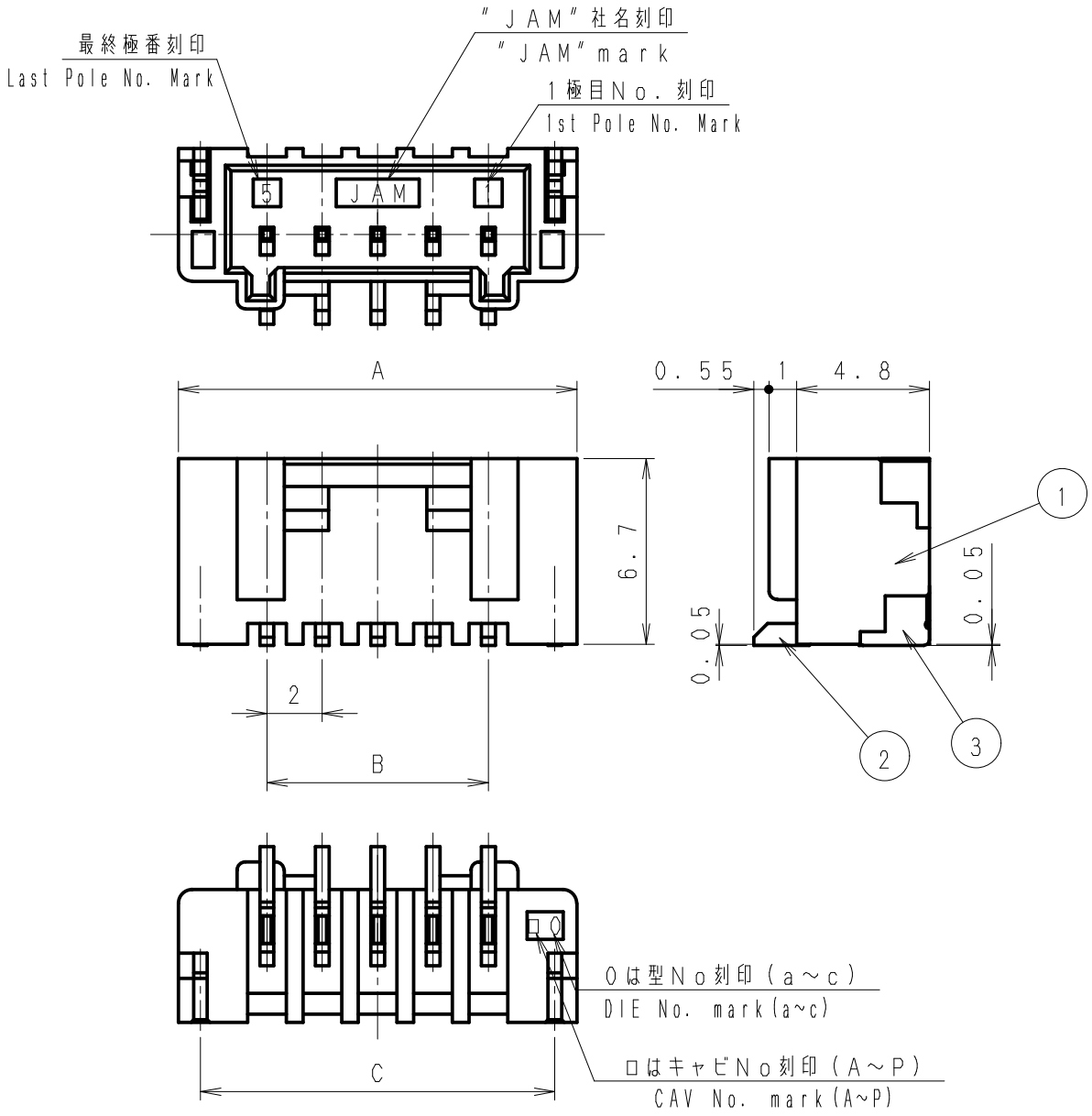

⑤	. .						③	黄銅 Brass	スズ銅メッキ SnCu-Plated		
④	. .				SJH2K-□□WV		②	黄銅 Brass	スズ銅メッキ SnCu-Plated		
③	. .						①	ナイロン6T (GF入り) Nylon 6T (With GF)	UL94V-0		
②	. .				製品番号 PRODUCT No.	No.		材 料 MATERIAL	備 考 NOTE	色 COLOR	
①	. .										
記号 No.	年月日 DATE	変更記事 REVISION RECORD	設計 DESIGN	承認 APP			製品名 NAME	SJHウエハー ストレート型 SJH Wafer, Straight type			
承認 APPROVED	確認 CHECKED		一般公差 TOLERANCE		尺度 SCALE	図番 DRAWING No.		JC-1079-120			
K. Koizumi	A. Kumakura		±0.3		4/1						
設計 DESIGN	製図 DRAWING		JAPAN AUTOMATIC MACHINE CO., LTD.								
A. Kumakura	N. Ogaki										

Poles	A	B	C
8	20.4	14.0	18.8
9	22.4	16.0	20.8
10	24.4	18.0	22.8
11	26.4	20.0	24.8
12	28.4	22.0	26.8
13	30.4	24.0	28.8
14	32.4	26.0	30.8
15	34.4	28.0	32.8

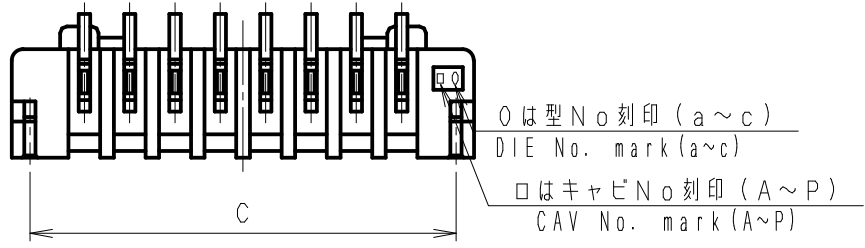
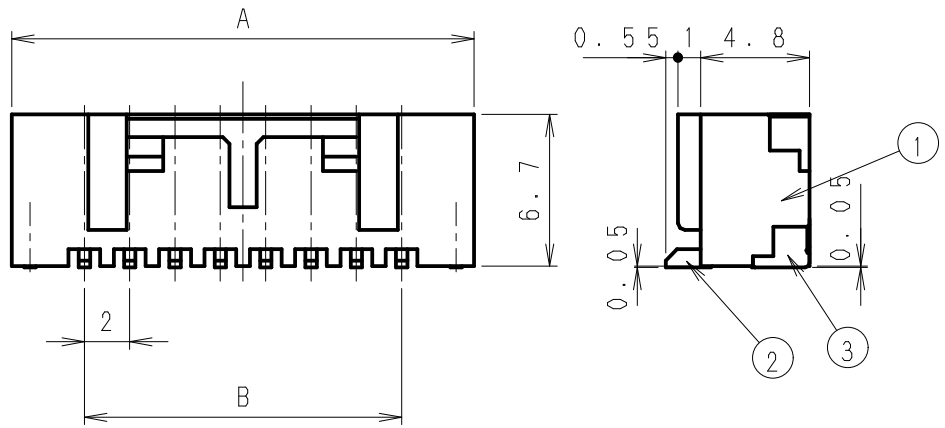
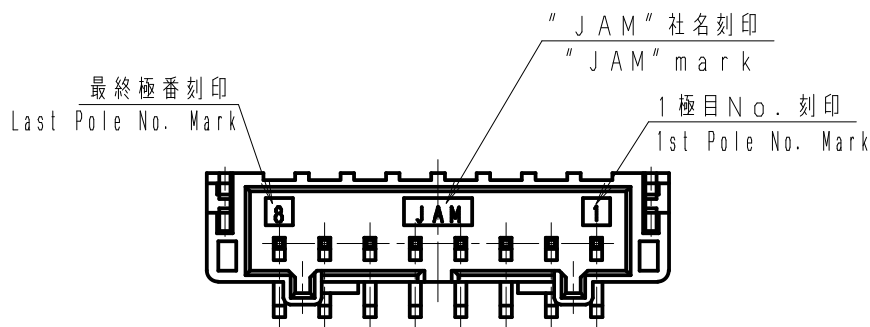

⑤	. . .						③	黄銅 Brass	スズ銅メッキ SnCu-Plated		
④	. . .				SJH2K-□□WV		②	黄銅 Brass	スズ銅メッキ SnCu-Plated		
③	. . .						①	ナイロン6T (GF入り) Nylon 6T (With GF)	UL94V-0		
②	. . .				製品番号 PRODUCT No.	No.		材 料 MATERIAL	備 考 NOTE	色 COLOR	
①	. . .										
記号 No.	年月日 DATE	変更記事 REVISION RECORD	設計 DESIGN	承認 APP				製品名 NAME	SJHウエハー ストレート型 SJH Wafer, Straight type		
承認 APPROVED	確認 CHECKED		一般公差 TOLERANCE		尺度 SCALE	図番 DRAWING No.					
K. Koizumi	A. Kumakura		±0.3		4/1	JC-1079-121					
設計 DESIGN	製図 DRAWING		JAPAN AUTOMATIC MACHINE CO., LTD.								
A. Kumakura	N. Ogaki										

第三角法
3rd ANGLE PROJECTION

単位：mm 注) . . . 図面を実測しないこと
UNIT : mm NOTES) . . . DO NOT SCALE

図番 DRAWING No.
JC-1079-122

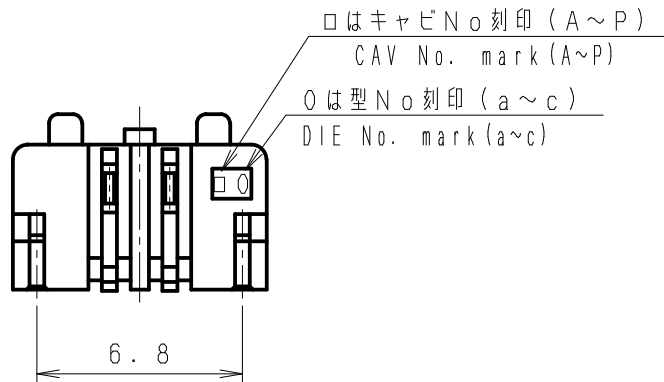
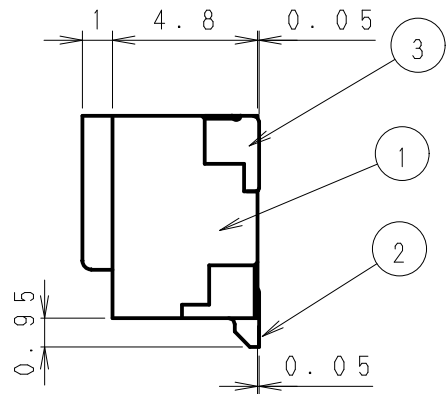
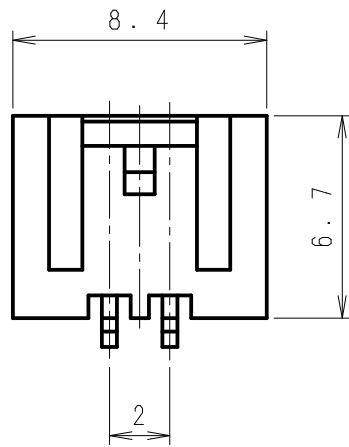
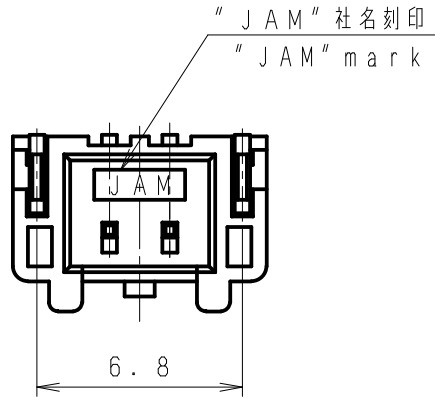

⑤	. .					③	黄銅 Brass	スズ銅メッキ SnCu-Plated	
④	. .				SJH2K-02WH	②	黄銅 Brass	スズ銅メッキ SnCu-Plated	
③	. .					①	ナイロン6T (GF入り) Nylon 6T (With GF)	UL94V-0	
②	. .				製品番号 PRODUCT No.	No.	材 料 MATERIAL	備 考 NOTE	色 COLOR
①	. .								
記号 No.	年月日 DATE	変更記事 REVISION RECORD	設計 DESIGN	承認 APP			製品名 NAME	SJHウエハー アンクル型 SJH Wafer, Angle type	
承認 APPROVED	確認 CHECKED		一般公差 TOLERANCE		尺度 SCALE	図番 DRAWING No.		JC-1079-122	
K. Koizumi	A. Kumakura		±0.3		4/1				
設計 DESIGN	製図 DRAWING								
A. Kumakura	N. Ogaki								

第三角法
3rd ANGLE PROJECTION

単位：mm 注) . . . 図面を実測しないこと
UNIT : mm NOTES) . . . DO NOT SCALE

図番 DRAWING No.
JC-1079-123

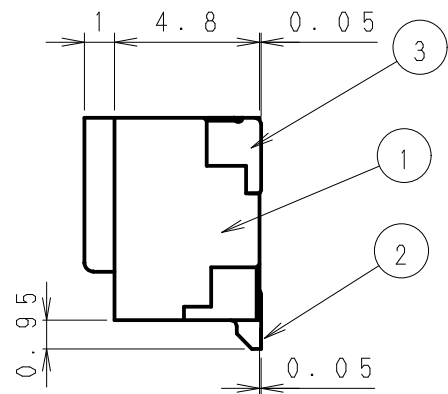
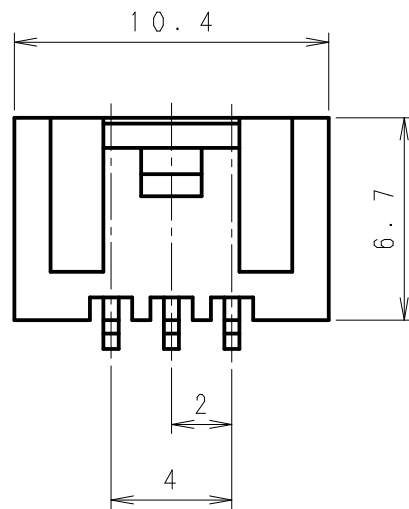
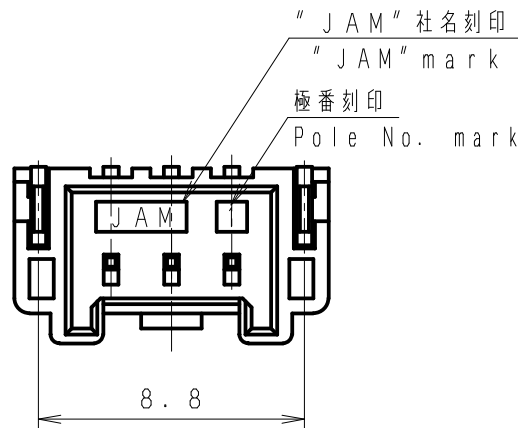

⑤	. .					③	黄銅 Brass	スズ銅メッキ SnCu-Plated	
④	. .				SJH2K-03WH	②	黄銅 Brass	スズ銅メッキ SnCu-Plated	
③	. .					①	ナイロン6T (GF入り) Nylon 6T (With GF)	UL94V-0	
②	. .				製品番号 PRODUCT No.	No.	材 料 MATERIAL	備 考 NOTE	色 COLOR
①	. .								
記号 No.	年月日 DATE	変更記事 REVISION RECORD	設計 DESIGN	承認 APP			製品名 NAME	SJHウエハー アンクル型 SJH Wafer, Angle type	
承認 APPROVED K. Koizumi	確認 CHECKED A. Kumakura	一般公差 TOLERANCE ±0.3		尺度 SCALE 4/1	図番 DRAWING No. JC-1079-123				
設計 DESIGN A. Kumakura	製図 DRAWING N. Ogaki		JAPAN AUTOMATIC MACHINE CO., LTD.						

Poles	A	B	C
4	12.4	6.0	10.8
5	14.4	8.0	12.8
6	16.4	10.0	14.8
7	18.4	12.0	16.8

最終極番刻印
Last Pole No. Mark

"JAM" 社名刻印
"JAM" mark

1極目No. 刻印
1st Pole No. Mark

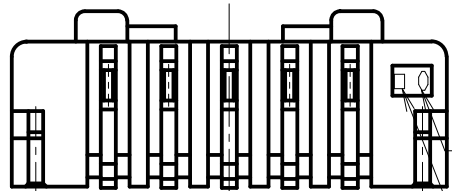
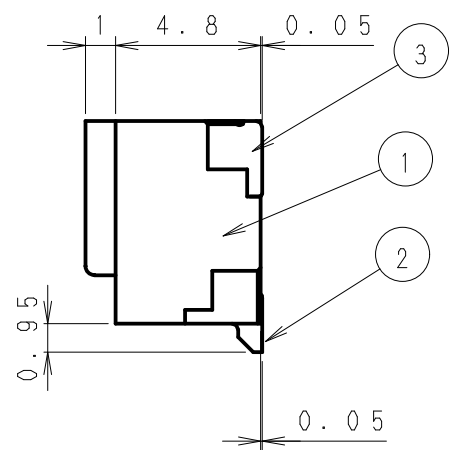
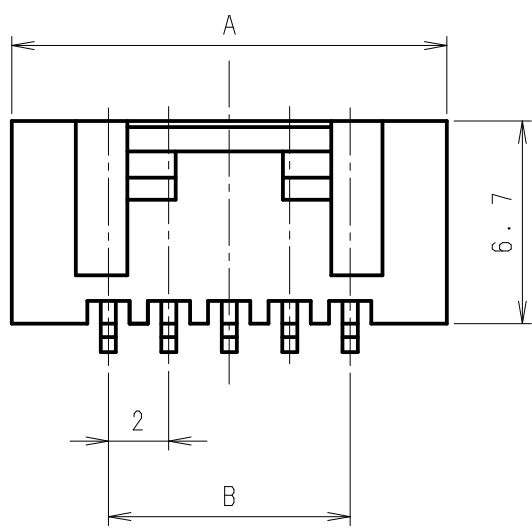
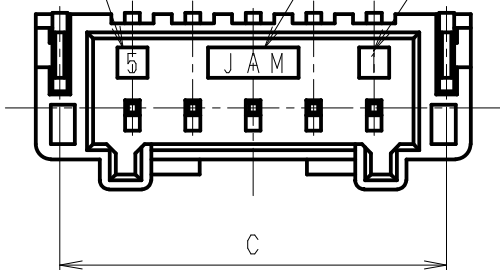

○は型No 刻印 (a~c)
DIE No. mark (a~c)

□はキャビNo 刻印 (A~P)
CAV No. mark (A~P)

⑤	. . .								
④	. . .				SJH2K-□□WH	③	黄銅 Brass	スズ銅メッキ SnCu-Plated	
③	. . .					②	黄銅 Brass	スズ銅メッキ SnCu-Plated	
②	. . .					①	ナイロン6T (GF入り) Nylon 6T (With GF)	UL94V-0	
①	. . .				製品番号 PRODUCT No.	No.	材 料 MATERIAL	備 考 NOTE	色 COLOR
記号 No.	年月日 DATE	変更記事 REVISION RECORD	設計 DESIGN	承認 APP			製品名 NAME	SJHウエハー アングル型 SJH Wafer, Angle type	
承認 APPROVED	確認 CHECKED		一般公差 TOLERANCE		尺度 SCALE	図番 DRAWING No.		JC-1079-124	
K. Koizumi	A. Kumakura		±0.3		4 / 1				
設計 DESIGN	製図 DRAWING		JAPAN AUTOMATIC MACHINE CO., LTD.						
A. Kumakura	N. Ogaki								

第三角法
3rd ANGLE PROJECTION

単位: mm 注) 図面を実測しないこと
UNIT: mm NOTES) DO NOT SCALE

図番 DRAWING No.
JC-1079-125

Poles	A	B	C
8	20.4	14.0	18.8
9	22.4	16.0	20.8
10	24.4	18.0	22.8
11	26.4	20.0	24.8
12	28.4	22.0	26.8
13	30.4	24.0	28.8
14	32.4	26.0	30.8
15	34.4	28.0	32.8

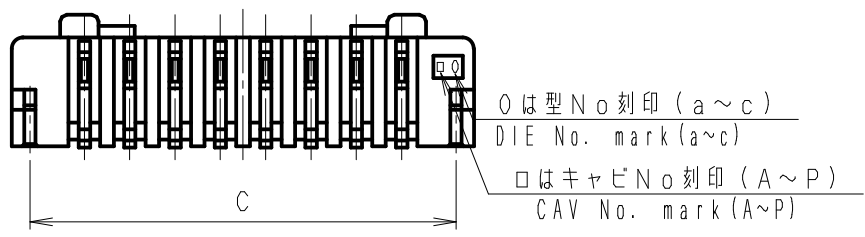
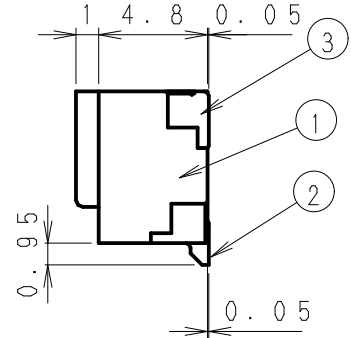
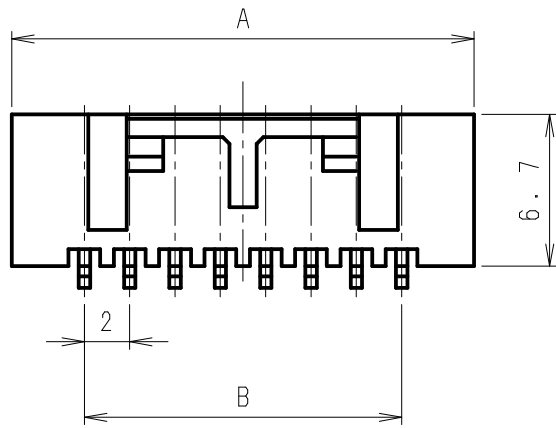
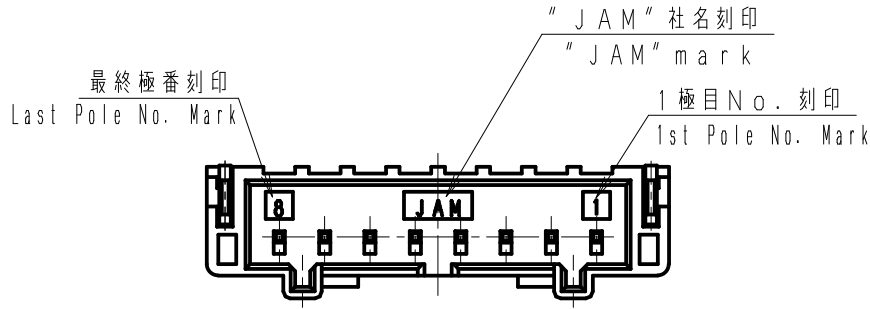

⑤	. .				SJH2K-□□WH	③	黄銅 Brass	スズ銅メッキ SnCu-Plated		
④	. .					②	黄銅 Brass	スズ銅メッキ SnCu-Plated		
③	. .					①	ナイロン6T(GF入り) Nylon 6T(With GF)	UL94V-0		
②	. .					製品番号 PRODUCT No.	No.	材 料 MATERIAL	備 考 NOTE	色 COLOR
①	. .									
記号 No.	年月日 DATE	変更記事 REVISION RECORD	設計 DESIGN	承認 APP	製品名 NAME		SJHウエハー アンクル型 SJH Wafer, Angle type			
承認 APPROVED	確認 CHECKED		一般公差 TOLERANCE		尺度 SCALE	図番 DRAWING No.				
K. Koizumi	A. Kumakura		±0.3		4/1	JC-1079-125				
設計 DESIGN	製図 DRAWING									
A. Kumakura	N. Ogaki									

極数 Poles	A	B	C	D	E	極数 Poles	A	B	C	D	E
2	32.0	28.4	14.2	14.4	32.4	9	44.0	40.4	20.2	28.4	44.4
3	32.0	28.4	14.2	16.4		10	44.0	40.4	20.2	30.4	
4	32.0	28.4	14.2	18.4		11	56.0	52.4	26.2	32.4	
5	44.0	40.4	20.2	20.4	44.4	12	56.0	52.4	26.2	34.4	56.4
6	44.0	40.4	20.2	22.4		13	56.0	52.4	26.2	36.4	
7	44.0	40.4	20.2	24.4		14	56.0	52.4	26.2	38.4	
8	44.0	40.4	20.2	26.4		15	56.0	52.4	26.2	40.4	

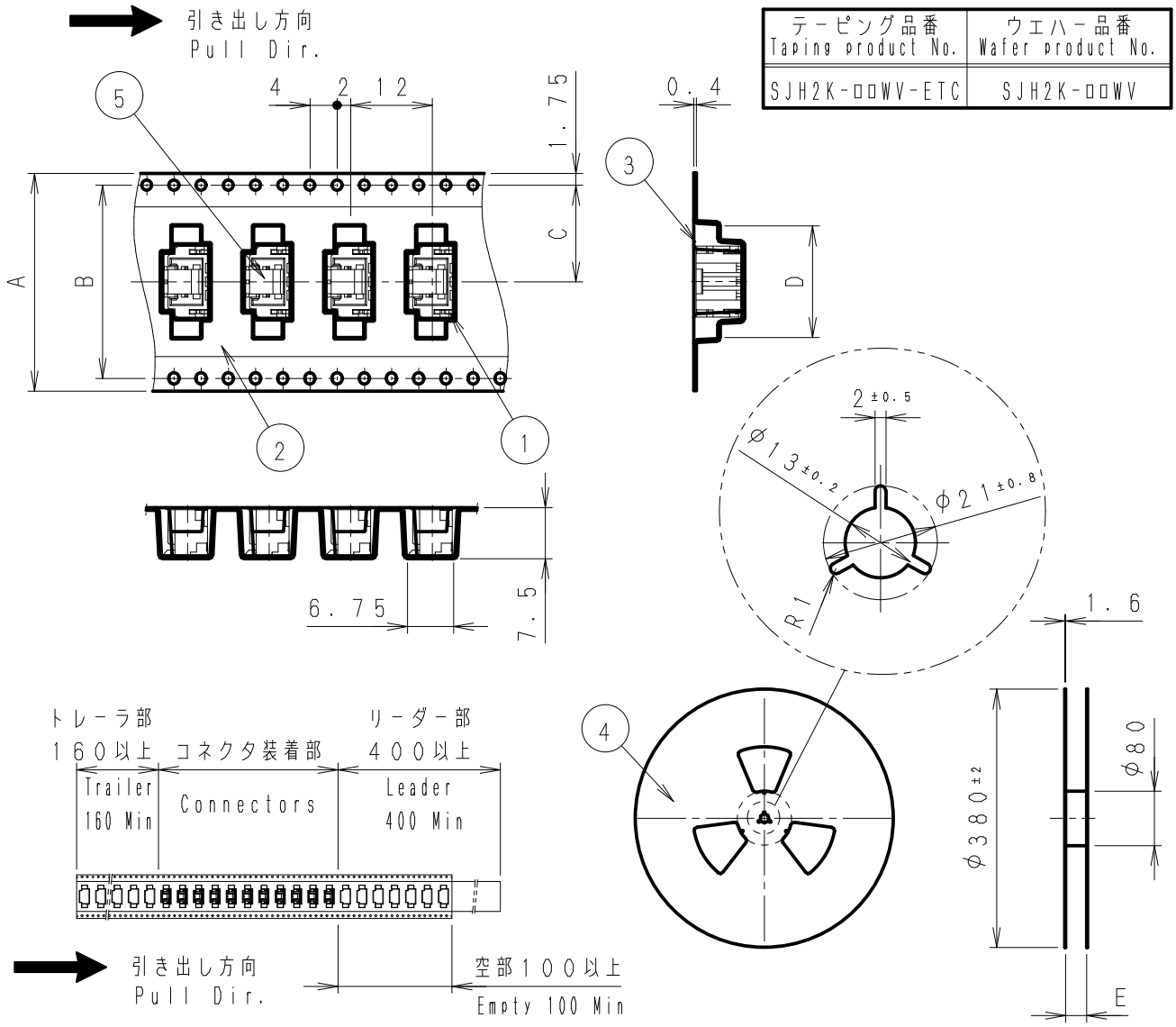

△7	. .					⑤	SJHウエハーカバー Cover for SJH Wafer	ナilon 6T (GFA) Nylon 6T with GF	
△6	. .					④	リール Reel	△1 ボール台紙又はPS (エコ) Card Board or PS, Eco	
△5	. .				△2 SJH2K-□□WV-ETC	③	カバーテープ Cover Tape	PS	
△4	. .					②	エンボステープ Emboss Tape	PS	
△3	. .					①	SJHウエハー SJH Wafer	-	
△2	19. 8. 5	品番変更 Product No. change	大垣 小泉	製品番号 PRODUCT No.	No.	製品名 PRODUCT NAME		材 料 MATERIAL	
△1	13. 4. 8	材質追加 Material addition	清水 草野			製品名 SJHウエハー-ストレート型 エンボステープ NAME SJH Wafer Straight Type Emboss Taping			
記号 No.	年月日 DATE	変更記事 REVISION RECORD	設計 DESIGN	承認 APP	製品名 SJHウエハー-ストレート型 エンボステープ NAME SJH Wafer Straight Type Emboss Taping				
承認 APPROVED	K. Kusano	確認 CHECKED	A. Kumakura	一般公差 TOLERANCE	±0.3	尺度 SCALE	1 / 1	図番 DRAWING No.	JC-1079-62
設計 DESIGN	A. Kumakura	製図 DRAWING	Y. Shimizu	JAPAN AUTOMATIC MACHINE CO., LTD.					

極数 Poles	A	B	C	D	E	極数 Poles	A	B	C	D	E
2	32.0	28.4	14.2	14.4	32.4	9	44.0	40.4	20.2	28.4	44.4
3	32.0	28.4	14.2	16.4		10	44.0	40.4	20.2	30.4	56.4
4	32.0	28.4	14.2	18.4		11	56.0	52.4	26.2	32.4	
5	44.0	40.4	20.2	20.4	12	56.0	52.4	26.2	34.4		
6	44.0	40.4	20.2	22.4	44.4	13	56.0	52.4	26.2	36.4	56.4
7	44.0	40.4	20.2	24.4		14	56.0	52.4	26.2	38.4	
8	44.0	40.4	20.2	26.4		15	56.0	52.4	26.2	40.4	

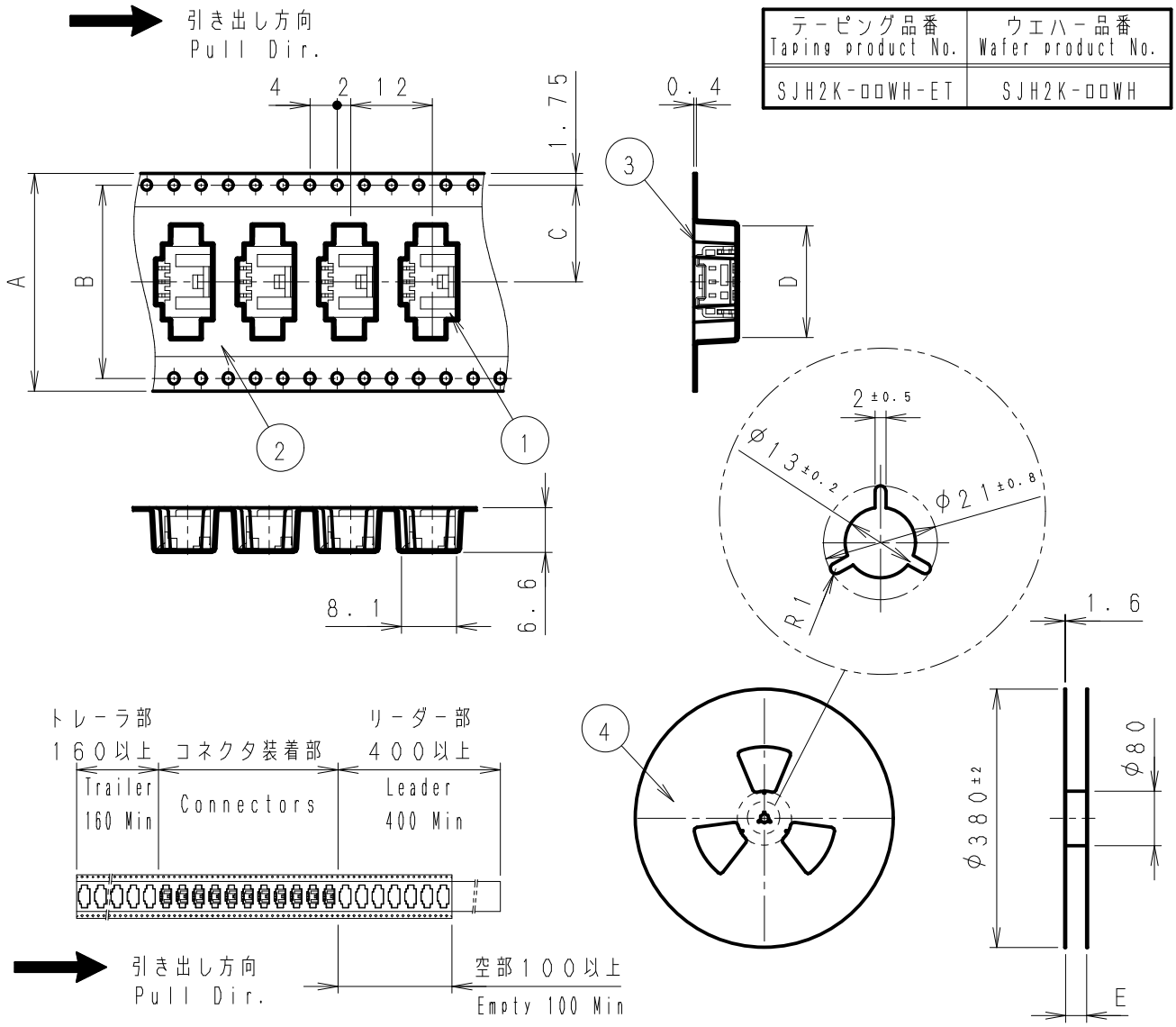

△6	. .						④	リール Reel	△1	ボール台紙又はPS (エコ) Card Board or PS, Eco
△5	. .						③	カバーテープ Cover Tape		PS
△4	. .						②	エンボステープ Emboss Tape		PS
△3	. .						①	SJHウェハー SJH Wafer		-
△2	19. 8. 5	品番変更 Product No. change	大垣	小泉	製品番号 PRODUCT No.	No.		製品名 PRODUCT NAME		材料 MATERIAL
△1	13. 4. 8	材質追加 Material addition	清水	草野						
記号 No.	年月日 DATE	変更記事 REVISION RECORD	設計 DESIGN	承認 APP			製品名 SJHウェハーアングル型 エンボステープ NAME SJH Wafer Angle Type Emboss Taping			
承認 APPROVED	K. Kusano	確認 CHECKED	A. Kumakura	一般公差 TOLERANCE	±0.3	尺度 SCALE	1 / 1		図番 DRAWING No.	JC-1079-63
設計 DESIGN	A. Kumakura	製図 DRAWING	Y. Shimizu	JAPAN AUTOMATIC MACHINE CO., LTD.						

製品番号 Product No.	A	適用極数 Poles	色 Color
SJH20-02CVBL	3.6	2, 3P	青 Blue
SJH20-04CV	6.5	4~7P	ナチュラル Natural
SJH20-08CVBK	10.0	8~15P	黒 Black

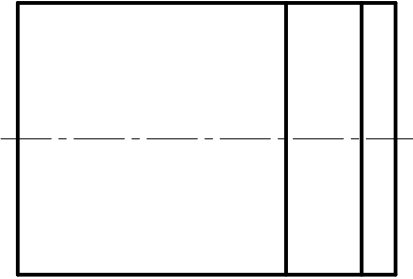

○は型No刻印 (a~c)
Model No. Mark (a~c)

□はキャビNo刻印 (A~P)
Cav No. Mark (A~P)

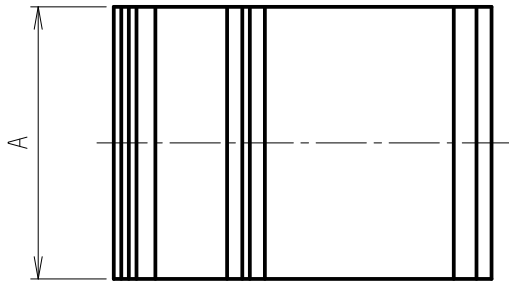
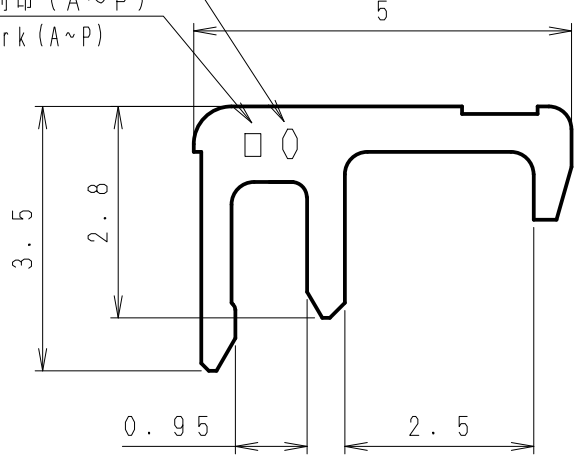

△4	. .				SJH20-00CV00	6Tナイロン (GF入) 6TNYLON (GF)		
△3	. .				製品番号 PRODUCT No.	材 料 MATERIAL	備考 NOTE	色 COLOR
△2	. .				No.			
△1	. .							
記号 No.	年月日 DATE	変更記事 REVISION RECORD	設計 DESIGN	承認 APP	製品名 NAME SJHウエハ-用 カバ- Cover for SJH wafer			
承認 APPROVED	確認 CHECKED		一般公差 TOLERANCE		尺度 SCALE	図番 DRAWING No.		
K. Kusano	A. Kumakura		±0.1		5 / 1	JC-0810-37Z		
設計 DESIGN	製図 DRAWING		JAPAN AUTOMATIC MACHINE CO., LTD.					
Y. Shimizu	Y. Shimizu							

第三角法
3rd ANGLE PROJECTION

単位: mm
UNIT: mm
注) 図面を実測しないこと
NOTES) DO NOT SCALE

図番 DRAWING No.
JC-0810-14Z

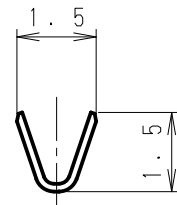
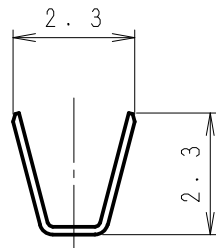
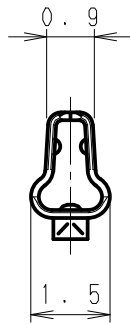
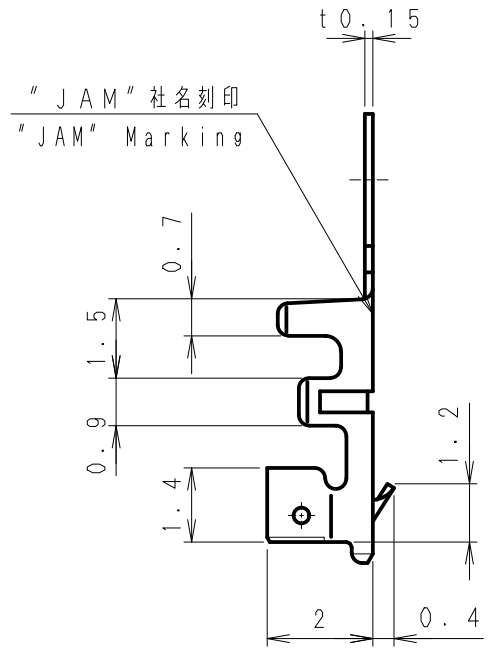
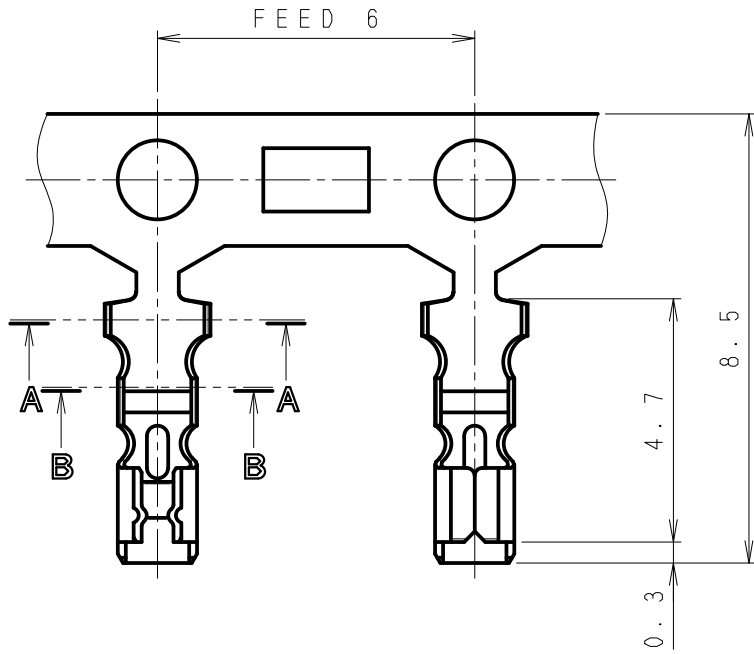

SEC A-A

SEC B-B

△6	. .								
△5	. .								
△4	. .								
△3	. .				720374-2MAC	リン青銅 Phosphor Bronze	スズメッキ材 Pre-tin Plated	AWG#24~#30	△ φ0.8~φ1.5
△2	. .				製品番号 PRODUCT No.	材 料 MATERIAL	表面処理 FINISH	適用電線 WIRE SIZE	被覆外径 INSULATION DIA
△1	05.12.12	被覆外径変更(範囲協定)	清水	堀内					
記号 No.	年月日 DATE	変更記事 REVISION RECORD	設計 DESIGN	承認 APP	製品名 NAME		ターミナル Terminal		
承認 APPROVED	確認 CHECKED		一般公差 TOLERANCE		尺度 SCALE	図番 DRAWING No.			
Y. Horiuchi	K. Kusano		±0.3		7 / 1	JC-0810-14Z			
設計 DESIGN	製図 DRAWING		 JAPAN AUTOMATIC MACHINE CO., LTD.						
K. Yokoyama	K. Yokoyama								

第三角法
3rd ANGLE PROJECTION

単位: mm
UNIT: mm
注) 図面を実測しないこと
NOTES) DO NOT SCALE

図番 DRAWING No.
JC-0810-15Z

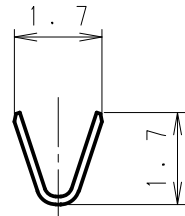
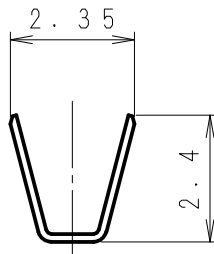
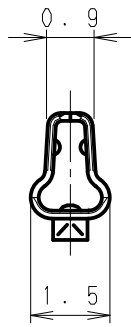
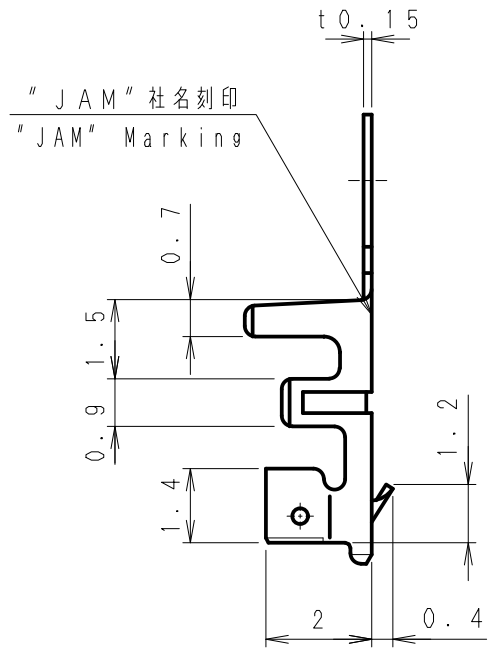
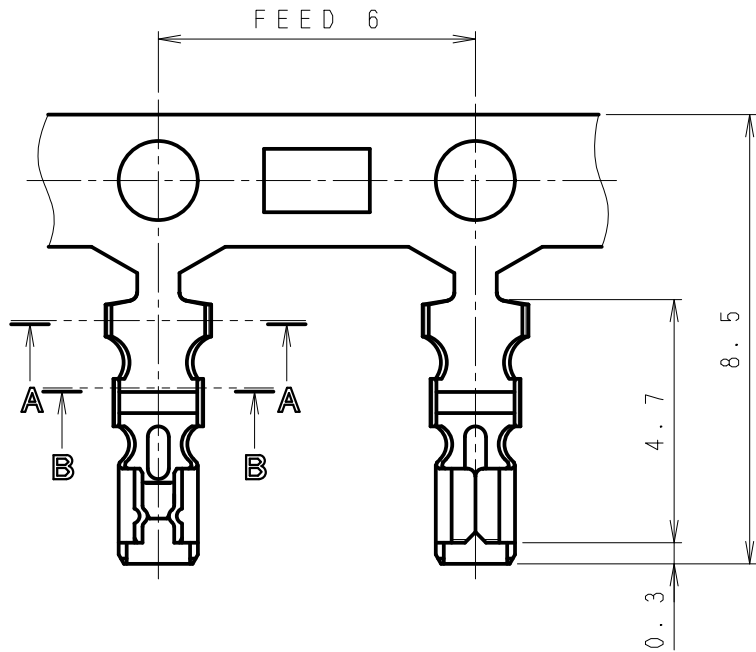

SEC A-A

SEC B-B

△6	. .								
△5	. .								
△4	. .								
△3	. .				720474-2MAC	リン青銅 Phosphor Bronze	スズメッキ材 Pre-tin Plated	AWG#22~#24	△ φ1.1~φ1.6
△2	. .				製品番号 PRODUCT No.	材 料 MATERIAL	表面処理 FINISH	適用電線 WIRE SIZE	被覆外径 INSULATION DIA
△1	05.12.12	被覆外径変更(範囲指定)	清水	堀内					
記号 No.	年月日 DATE	変更記事 REVISION RECORD	設計 DESIGN	承認 APP	製品名 NAME		ターミナル Terminal		
承認 APPROVED	確認 CHECKED		一般公差 TOLERANCE	尺度 SCALE	図番 DRAWING No.		JC-0810-15Z		
Y. Horiuchi	K. Kusano		±0.3	7/1	JC-0810-15Z				
設計 DESIGN	製図 DRAWING		 JAPAN AUTOMATIC MACHINE CO., LTD.						
K. Yokoyama	K. Yokoyama								

第三角法
3rd ANGLE PROJECTION

単位: mm
UNIT: mm

注) 図面を実測しないこと
NOTES) DO NOT SCALE

図番 DRAWING No.
JC-1079-64

極数 Poles	A	B	極数 Poles	A	B
2	2.0	6.8	9	16.0	20.8
3	4.0	8.8	10	18.0	22.8
4	6.0	10.8	11	20.0	24.8
5	8.0	12.8	12	22.0	26.8
6	10.0	14.8	13	24.0	28.8
7	12.0	16.8	14	26.0	30.8
8	14.0	18.8	15	28.0	32.8

SJH2K-□□WV□用
(SJH2K-□□WV□ Type)

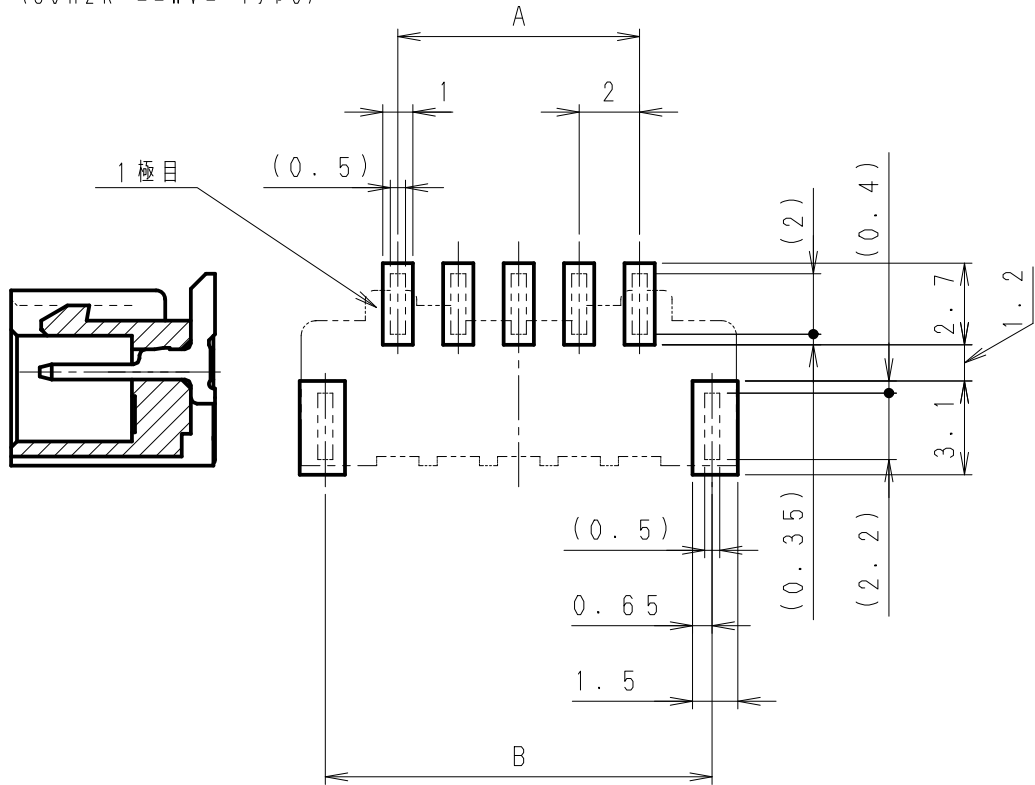

△6	. .								
△5	. .								
△4	. .								
△3	. .								
△2	. .				製品番号 PRODUCT No.	No.	材 料 MATERIAL	備考 NOTE	色 COLOR
△1	. .								
記号 No.	年月日 DATE	変更記事 REVISION RECORD	設計 DESIGN	承認 APP	製品名 SJHコネクタ 推奨基板レイアウト(ストレート型) NAME SJH Connector P.C.B. Layout (Straight)				
承認 APPROVED	K. Kusano	確認 CHECKED	A. Kumakura	一般公差 TOLERANCE	±0.1	尺度 SCALE	4 / 1	図番 DRAWING No.	JC-1079-64
設計 DESIGN	A. Kumakura	製図 DRAWING	Y. Shimizu	JAPAN AUTOMATIC MACHINE CO., LTD.					

第三角法
3rd ANGLE PROJECTION

単位: mm
UNIT: mm

注) 図面を実測しないこと
NOTES) DO NOT SCALE

図番 DRAWING No.
JC-1079-65

極数 Poles	A	B	極数 Poles	A	B
2	2.0	6.8	9	16.0	20.8
3	4.0	8.8	10	18.0	22.8
4	6.0	10.8	11	20.0	24.8
5	8.0	12.8	12	22.0	26.8
6	10.0	14.8	13	24.0	28.8
7	12.0	16.8	14	26.0	30.8
8	14.0	18.8	15	28.0	32.8

SJH2K-□□WH□用
(SJH2K-□□WH□ Type)

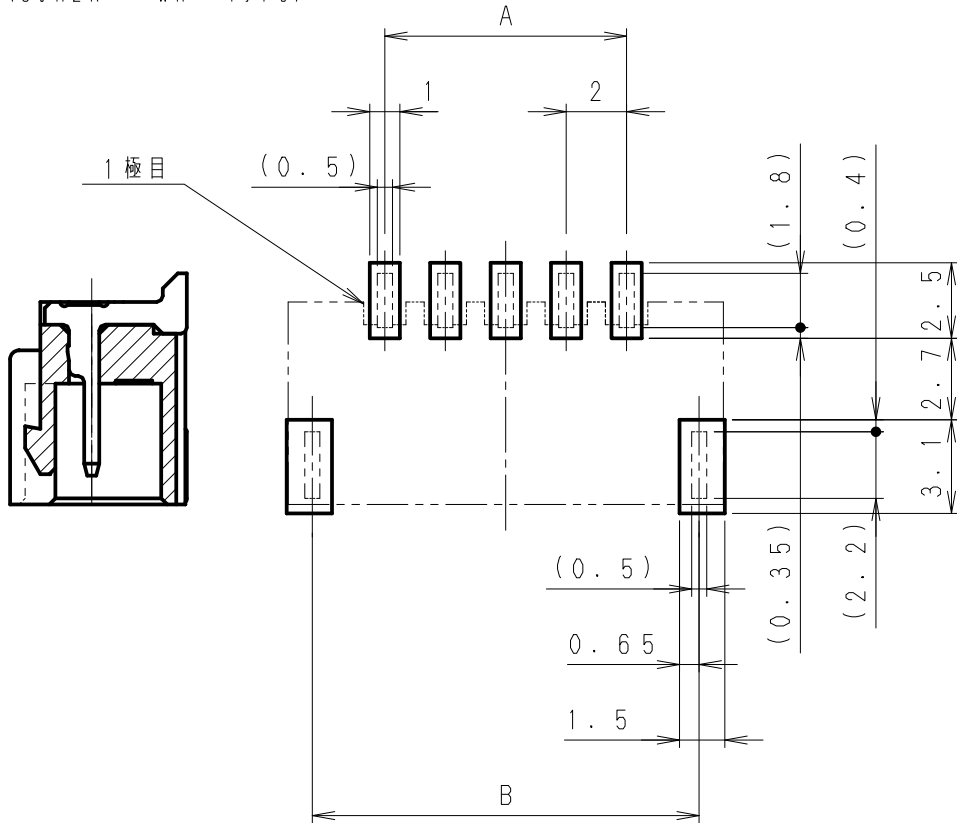

△6	. .								
△5	. .								
△4	. .								
△3	. .								
△2	. .				製品番号 PRODUCT No.	No.	材 料 MATERIAL	備考 NOTE	色 COLOR
△1									
記号 No.	年月日 DATE	変更記事 REVISION RECORD	設計 DESIGN	承認 APP	製品名 NAME SJHコネクタ 推奨基板レイアウト(アングル型) SJH Connector P.C.B. Layout(Angle)				
承認 APPROVED K. Kusano		確認 CHECKED A. Kumakura		一般公差 TOLERANCE ±0.1	尺度 SCALE 4/1	図番 DRAWING No. JC-1079-65			
設計 DESIGN A. Kumakura		製図 DRAWING Y. Shimizu			JAPAN AUTOMATIC MACHINE CO., LTD.				