

Specification No.

SA-1048S1-A10-1/9

御中

製品名 Product Name	JZコネクタ JZ connector	
製品番号 Product Number	ターミナル Terminal	507110-2MA
		507130-2MA
	ハウジング Housing	JZ15-□□HG

受領印欄  
Acknowledged

---

3					承認 Approved	確認 Checked	作成 Prepared
2							
1							
Rev.	2014. 11. 25	書式の変更 Form change.	—	—			
Issue	1997. 12. 24		—	—			
No.	日付 Date	変更内容 Revision	変更 Change	承認 Approved			

JAPAN AUTOMATIC MACHINE CO., LTD

## 1. 適用範囲 (Scope)

この製品仕様書は「JZコネクタ」の一般仕様及び性能について規定する。  
The present document concerns general specifications and performances of "JZ connector".

## 2. 製品名・製品番号 (Product name and number)

製品名 Product Name	製品番号 Number	材料及び表面処理 Material and surface treatment
ターミナル Terminal	5 0 7 1 1 0 - 2MA	黄銅 スズメッキ材
	5 0 7 1 3 0 - 2MA	Brass, Pre-tin Plated
ハウジング Housing	J Z 1 5 - □ □ H G	6 6 ナイロン (UL94V-0) 66 nylon (UL94V-0)

## 3. 形状・寸法・材料 (Geometry and materials)

添付図面による。  
Refer to attached drawings.

図面番号 Drawing No.	製品名 Product name	記号 Mark
J C - 0 1 1 4 - 0 7	J Z コネクタ A s s ' y JZ connector Ass'y	0
J C - 0 3 9 3 - 0 1 Z	J Z コネクタ A s s ' y JZ connector Ass'y	0
J C - 0 1 1 4 - 0 8	J Z コネクタ ハウジング JZ connector housing	0
J C - 0 1 1 4 - 0 9	J Z コネクタ ターミナル JZ connector terminal	0
J C - 0 3 9 3 - 0 2 Z	J Z コネクタ ターミナル JZ connector terminal	0

## 4. 定格 (Rated values)

項目 Item	規格値 Description	
定格電圧 Rated voltage	200V AC, DC 200 V AC, DC	
定格電流 Rated current	1 A (注1) 1 A (Note 1)	
使用温度範囲 Temperature range	-20 ~ +85℃ (通電による温度上昇分を含む) -20 to +85℃ (heating by energization included)	
適用電線範囲 (注2) Wire size (Note 2)	AWG #28 ~ #30 最大被覆外径 $\phi$ 1.0mm AWG #28 to #30 Maximum diameter of insulation covering $\phi$ 1.0 mm	
適用プリント基板 Applicable P.C. board	厚さ Thickness	507110 : 0.4 ~ 1.2 mm 507130 : 1.6 mm
	穴径 Hole diameter	$\phi$ 0.8 mm (両サイド : $\phi$ 0.7 $\pm$ 0.05 mm) $\phi$ 0.8 mm (both sides $\phi$ 0.7 $\pm$ 0.05 mm)
保存温度 Storage temperature	-30 ~ +60℃ (90% RH以下) -30 to +60℃ (90% RH or less)	

(注1) 定格電流はターミナル接触部の定格値であり、実使用においては使用電線の定格電流、使用温度により決定される。

(注2) 電線はより線を使用し、単線等の特殊電線は原則として使用出来ません。

(Note 1) The rated current shown is at the terminal contact section. Practically, it varies depending on rated current of particular wire and operating temperature.

(Note 2) Use a stranded wire. Do not use solid or other special wires.

## 5. 性能 (Performances)

性能は、下表に示す試験条件及び方法で試験を実施したとき、各項目に規定する規格値を満足すること。尚、試験は特に指定のない限り JIS C 60068-1 [環境試験方法 (電気、電子) 通則] に規定された試験場所の標準にて実施する。

The performances tested under the conditions and methods given in the table below shall conform to the respective specifications. Unless otherwise specified, carry out the tests according to the standards of a place of test stipulated in IEC 60068-1 "General Rules of Environmental Testing Method (Electric and Electronic)".

## 5-1 外観 (Appearance)

No.	項目 Item	規格値 Description	条件 Check
5-1-1	外観 Appearance	使用上有害となる様な割れ・変形等が無いこと Crack, deformation, etc. harmful in use are not allowed	目視 Visual

## 5-2 機械的性能 (Mechanical properties)

No.	項目 Item	規格値 Description		試験条件及び方法 Check
5-2-1	ターミナル 挿入力 Terminal insertion force	4.9 N 以下 4.9 N or less		ターミナルをハウジングに挿入するのに 要する力を万能試験機を用いて測定する。 試験速度 25 mm/min The inserting force when terminal is put into housing shall be measured. Pull out speed 25 mm/min
5-2-2	ターミナル 保持力 Terminal pull-out force	9.8 N 以上 9.8 N or more		ハウジングに装着したターミナルを軸方 向に引っ張り、ハウジングからターミナ ルが離脱するときの荷重を万能試験機を 用いて測定する。 試験速度 25 mm/min The axial pull out force shall be measured when the terminal is drawn out from the housing. Pull out speed 25 mm/min
5-2-3	プリント基板 への挿入力 Insertion force to P. C. B	別表A参照 See Appended Table A		プリント基板に挿入するのに要する力を 万能試験機を用いて測定する。 テスト基板 t = 0.8 mm使用 The strength for inserting into P. C. B shall be measured by Universal Testing Instrument. Test P. C. B uses t=0.8mm
5-2-4	プリント基板 への保持力 Pull-out force to P. C. B	別表A参照 See Appended Table A		プリント基板から離脱するときの荷重を 万能試験機を用いて測定する。 テスト基板 t = 0.8 mm使用 Measure the retaining force at the speed of 25 mm/min. Test P. C. B uses t=0.8mm
5-2-5	圧着部引張強度 Tensile strength of crimped section UL1007 UL1061 UL1571	電線 Wire size	強度 N 以上 Minimum strength in N	ターミナルのワイヤバレルと電線導体を 圧着し、治具で固定し電線の軸方向に引 っ張る。 試験速度 25 mm/min Crimp the terminal's wire barrel and conductor together, fasten the altogether, and pull the wire axially at 25 mm/min.
		AWG#28	9.8	
		AWG#30	4.9	

## 5-3 電氣的性能 (Electrical characteristics)

No.	項目 Item	規格値 Description	試験条件及び方法 Check
5-3-1	接触抵抗 Contact resistance	初期 10 mΩ 以下 10 mΩ or less initially	電気抵抗を測定し、電線抵抗を差し引いて接触抵抗とする。 試験電流 15mA以下 (20mV以下) The resistance which wire resistance is deducted shall be measured. Test current 15mA or less (20mV or less)
5-3-2	絶縁抵抗 Insulation resistance	500 MΩ 以上 500 MΩ or more	ハウジング外面とターミナル相互間及び隣接するターミナル間にDC500Vを印して測定する。 Apply 500 V DC between housing and each of terminals, and between adjacent terminals
5-3-3	耐電圧 Dielectric strength	AC 500 V / 1分間 異常なきこと Shall remain normal	ハウジング外面とターミナル相互間及び隣接するターミナル間にて測定する。 Apply 500 V AC for 1 min between connector housing and each of terminals, and between adjacent terminals
5-3-4	温度上昇 Temperature rise	30 K 以下 (適用最大電線による) 30 K or less (With thickest applicable wire)	ハウジングの全極にターミナルを装着し、嵌合させて各ターミナルを直列に接続し、最大定格電流を通電した時のターミナル部の温度上昇を測定する。 Mount the terminals on all housing poles, engage them, connect all terminals in series, apply rated current, and measure the temperature at terminals

## 5-4 耐久環境性能 (Durability)

No.	項目 Item	規格値 Description	試験条件及び方法 Check
5-4-1	耐湿性 Moisture	接触抵抗 Contact resistance	20mΩ 以下 20 mΩ or less
		絶縁抵抗 Insulation resistance	500MΩ 以上 500 MΩ or more
		耐電圧 Dielectric strength	AC500V/ 1分間 異常なきこと Shall remain normal at 500 V AC for 1 min
		外観 Appearance	異常なきこと Shall remain normal
5-4-2	耐塩水噴霧性 Salt mist	接触抵抗 Contact resistance	20mΩ 以下 20 mΩ or less
		絶縁抵抗 Insulation resistance	500MΩ 以上 500 MΩ or more
		耐電圧 Dielectric strength	AC500V/ 1分間 異常なきこと Shall remain normal at 500 V AC for 1 min
		外観 Appearance	異常なきこと Shall remain normal

No.	項目 Item	規格値 Description		試験条件及び方法 Check
5-4-3	耐硫化水素 ガス性  Hydrogen sulfide	接触抵抗	20mΩ 以下	下記硫化水素ガス中に放置。 濃度 3 ± 1 ppm 温度 40 ± 2℃ 湿度 90 ~ 95% RH 放置時間 24時間 室内で1 ~ 2時間放置後測定。  It keeps in hydrogen sulfide for 24 h. Density 3 ± 1 ppm. Temperature 40 ± 2°C. Relative humidity 90 to 95%. Leave the sample at the room for 1 to 2 h before check.
		Contact resistance	20 mΩ or less	
		絶縁抵抗	500MΩ 以上	
		Insulation resistance	500 MΩ or more	
5-4-4	耐アンモニア性  Ammonia	耐電圧	AC500V / 1分間 異常なきこと	下記アンモニア水の入ったデシケーター容器中に放置 濃度 3% 温度 25 ± 10℃ 容積比 25 ml / l 放置時間 8時間 室内で1 ~ 2時間放置後測定。  It keeps it in desiccator filled with following aqueous ammonia for 8 h. Concentration 3%. Temperature 25 ± 10°C. Volume ratio 25 ml / l Leave the sample at the room for 1 to 2 h before check.
		Dielectric strength	Shall remain normal at 500 V AC for 1 min	
		外観	異常なきこと	
		Appearance	Shall remain normal	

No.	項目 Item	規格値 Description		試験条件及び方法 Check
5-4-5	耐熱衝撃性 Heat shock	接触抵抗 Contact resistance	20mΩ 以下 20 mΩ or less	下記条件に放置 1. 低温側 -40 ± 2°C 30分 2. 室温 +25 ± 10°C 10分以内 3. 高温側 +85 ± 2°C 30分 4. 室温 +25 ± 10°C 10分以内 1～4を5サイクル行う。  It subject to 5 cycles of following sequence. 1. Low temperature -40 ± 2°C for 30 min. 2. Room temperature +25 ± 10°C within 10 min. 3. High temperature +85 ± 2°C for 30 min. 4. Room temperature +25 ± 10°C within 10 min.
		絶縁抵抗 Insulation resistance	500MΩ 以上 500 MΩ or more	
		耐電圧 Dielectric strength	AC500V / 1分間 異常なきこと Shall remain normal at 500 V AC for 1 min	
		外観 Appearance	異常なきこと Shall remain normal	

## 5-5 半田付性能 (Soldering characteristics)

No.	項目 Item	規格値 Description	試験条件及び方法 Check
5-5-1	はんだ付性 Solderability	半田面に半田がムラ無く全体に付くこと 浸漬面積の90%以上 90% or more of dipped solder side shall be coated uniformly with solder	基板にハウジングを取り付け下記条件の半田槽に半田付部を浸漬する。 はんだ槽温度 230 ± 5°C 浸漬時間 3 ± 0.5秒  Mounting the housing into P.C.B. After 5 ~ 10 seconds immersing in Flux maintained in soldering as following conditions. Temperature 230 ± 5°C Time 3 ± 0.5 Sec
5-5-2	はんだ耐熱性 Soldering heat	機能を損なう変形・損傷等のないこと Shall remain free from deformation, damage, etc. adversely affecting the functions	基板にハウジングを取り付け下記条件半田槽に半田付部を浸漬する。 はんだ槽温度 260 ± 5°C 浸漬時間 5 ± 1秒  Mounting the housing into P.C.B. immersed in soldering as following conditions. Temperature 260 ± 5°C Time 5 ± 1 Sec



## 【表A】挿入力及び引抜力

(Table A: Insertion force and pull-out force)

	挿入力(N以下) Maximum insertion force in N	保持力(N以上) Minimum pull-out force in N
単極	9.8	0.29
2P	19.6	0.58
3P	19.6	0.98
4P	29.4	1.47
5P	39.2	1.96
6P	49.0	2.45
7P	49.0	2.94
8P	58.8	3.43
9P	58.8	3.92
10P	58.8	4.41
11P	68.6	4.90
12P	68.6	5.39
13P	68.6	5.88
14P	78.4	6.37
15P	78.4	6.86

極数	A	B	極数	A	B
2	1.5	3.7	9	12.0	14.2
3	3.0	5.2	10	13.5	15.7
4	4.5	6.7	11	15.0	17.2
5	6.0	8.2	12	16.5	18.7
6	7.5	9.7	13	18.0	20.2
7	9.0	11.2	14	19.5	21.7
8	10.5	12.7	15	21.0	23.2

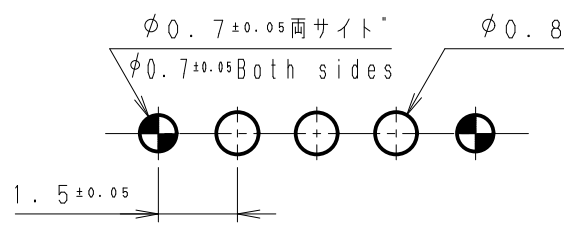
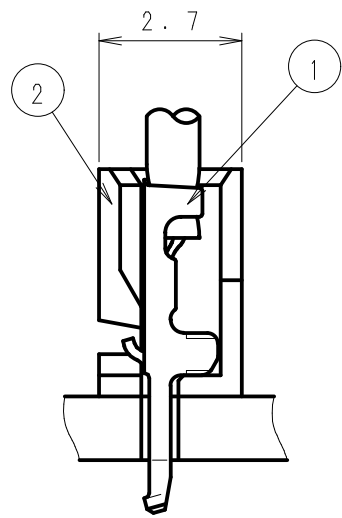
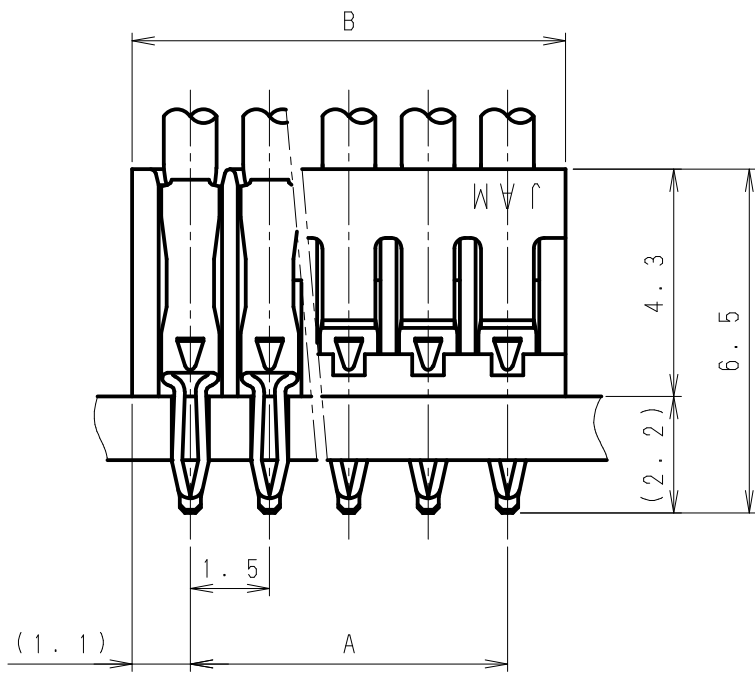
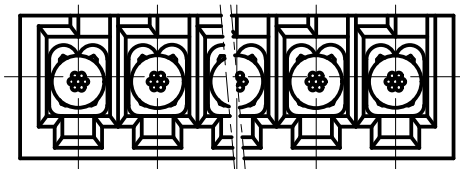

推奨基板レイアウト  
P.C.B. Layout

△6	. .				JZ15-□□HG	②	66ナイロン 66Nylon				
△5	. .				507110-2MA	①	黄銅 Brass	AWG #28~#30	MAX φ1.0	t0.4~1.2	
△4	. .				製品番号 PRODUCT No.	No.	材 料 MATERIAL	適用電線 WIRE SIZE	被覆外径 INSULATION DIA	適応プリント基板 APPLICABLE P.C.B	
△3	. .				記号 No.	年月日 DATE	変更記事 REVISION RECORD	設計 DESIGN	承認 APP	製品名 NAME	
△2	. .									JZコネクタ Ass'y JZ Connector Ass'y	
△1	. .									図番 DRAWING No. JC-0114-07	
承認 APPROVED Y. Horiuchi		確認 CHECKED K. Koizumi		一般公差 TOLERANCE ±0.3		尺度 SCALE 7/1					
設計 DESIGN N. Yarimizu		製図 DRAWING N. Yarimizu		JAPAN AUTOMATIC MACHINE CO., LTD.							

極数	A	B	極数	A	B
2	1.5	3.7	9	12.0	14.2
3	3.0	5.2	10	13.5	15.7
4	4.5	6.7	11	15.0	17.2
5	6.0	8.2	12	16.5	18.7
6	7.5	9.7	13	18.0	20.2
7	9.0	11.2	14	19.5	21.7
8	10.5	12.7	15	21.0	23.2

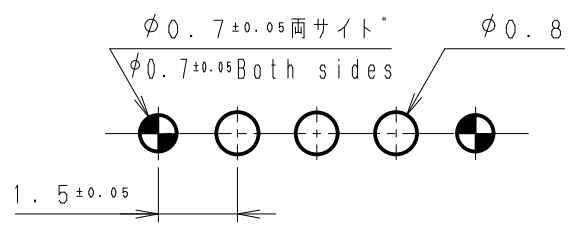
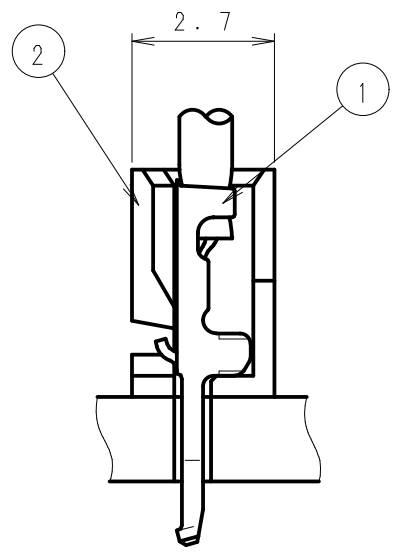
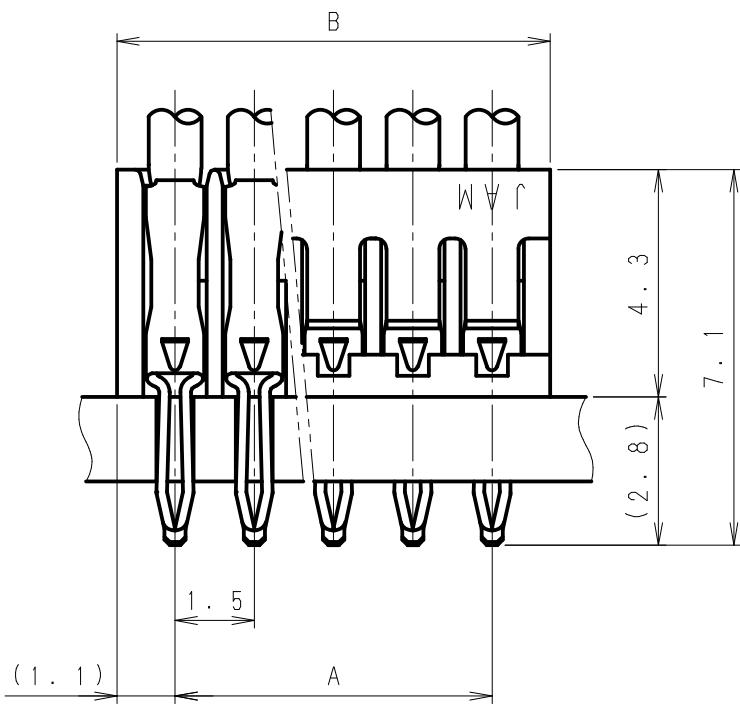
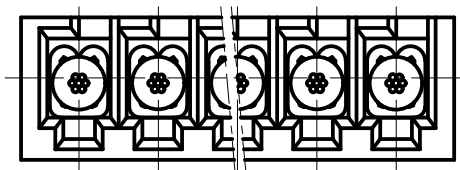

推奨基板レイアウト  
P.C.B. Layout

△6	. .				JZ15-□□HG	②	66ナイロン 66Nylon							
△5	. .				507130-2MA	①	黄銅 Brass	AWG #28~#30	MAX φ1.0	t1.6				
△4	. .				製品番号 PRODUCT No.	No.	材 料 MATERIAL	適用電線 WIRE SIZE	被覆外径 INSULATION DIA	通応プリント基板 APPLICABLE P.C.B				
△3	. .				記号 No. 年月日 DATE					変更記事 REVISION RECORD	設計承認 DESIGN APP	製品名 NAME JZコネクタ Ass'y JZ Connector Ass'y		
△2	. .				承認 APPROVED K. Kusano		確認 CHECKED A. Kumakura		一般公差 TOLERANCE ±0.3	尺度 SCALE 7/1	図番 DRAWING No. JC-0393-01Z			
△1	. .				設計 DESIGN Y. Shimizu		製図 DRAWING Y. Shimizu		<b>JAPAN AUTOMATIC MACHINE CO., LTD.</b>					

極数	製品番号	A	B	極数	製品番号	A	B
2	JZ15-02HG	1.5	3.7	9	JZ15-09HG	12.0	14.2
3	JZ15-03HG	3.0	5.2	10	JZ15-10HG	13.5	15.7
4	JZ15-04HG	4.5	6.7	11	JZ15-11HG	15.0	17.2
5	JZ15-05HG	6.0	8.2	12	JZ15-12HG	16.5	18.7
6	JZ15-06HG	7.5	9.7	13	JZ15-13HG	18.0	20.2
7	JZ15-07HG	9.0	11.2	14	JZ15-14HG	19.5	21.7
8	JZ15-08HG	10.5	12.7	15	JZ15-15HG	21.0	23.2

"JAM" 社名刻印

JAM" Mark

キャビ" No. 最終極番刻印

Cav No., Last pole mark

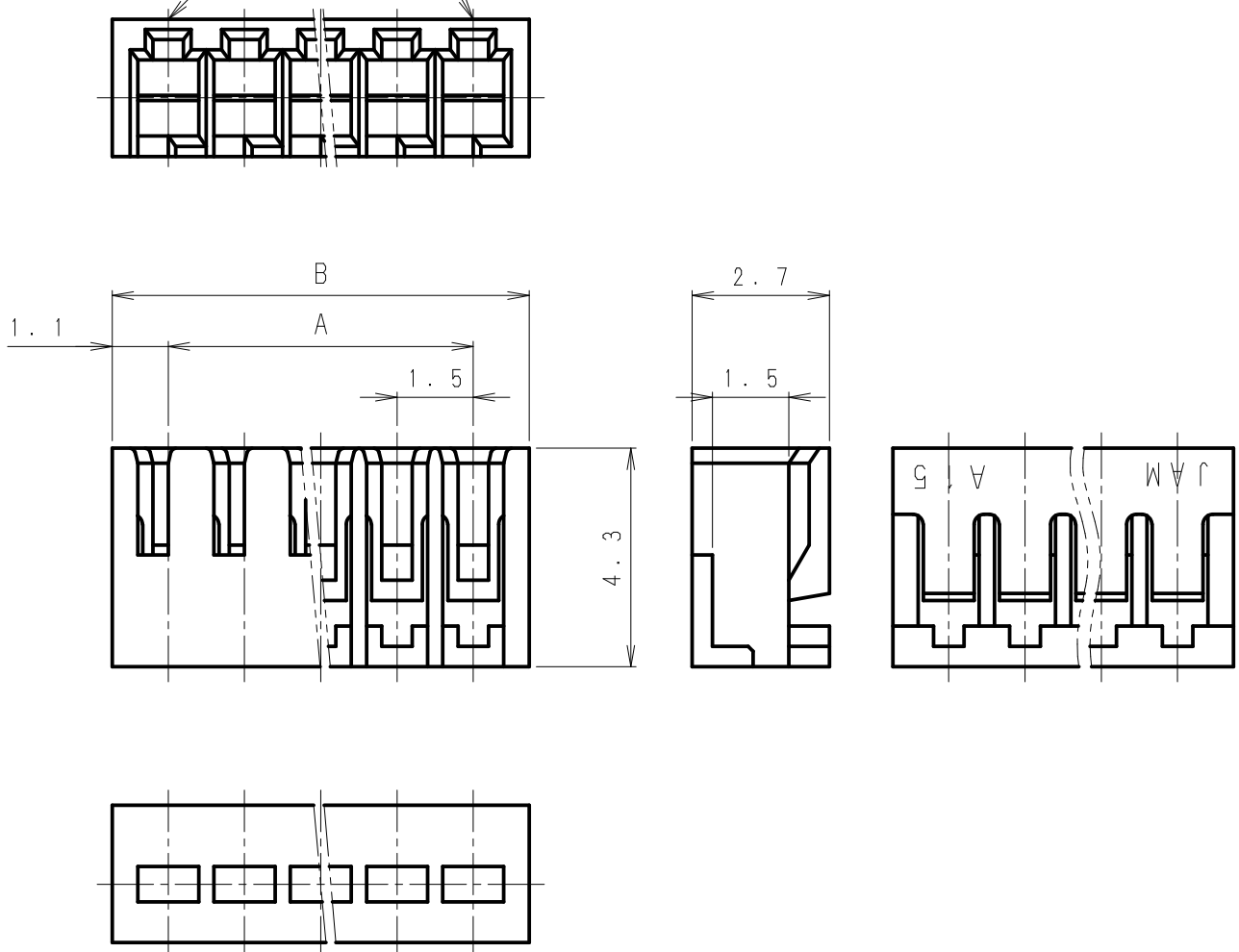

④	. .				JZ15-□□HG	66 Nylon (UL94 V-0)				
③	. .				製品番号 PRODUCT No.	No.	材 料 MATERIAL	表面処理 FINISH	適用電線 WIRE SIZE	被覆外径 INSULATION DIA
②	. .									
①	. .									
記号 No.	年月日 DATE	変更記事 REVISION RECORD	設計 DESIGN	承認 APP	製品名 NAME			JZコネクタ ハウジング JZ Connector housing		
承認 APPROVED	確認 CHECKED		一般公差 TOLERANCE		尺度 SCALE	図番 DRAWING No.				
Y. Horiuchi	K. Koizumi		±0.3		7 / 1	JC-0114-08				
設計 DESIGN	製図 DRAWING				JAPAN AUTOMATIC MACHINE CO., LTD.					
N. Yarimizu	N. Yarimizu									

第三角法  
3rd ANGLE PROJECTION

単位: mm  
UNIT: mm  
注) . . . . . 図面を実測しないこと  
NOTES) . . . . . DO NOT SCALE

図番 DRAWING No.  
JC-0114-09

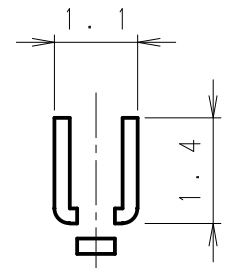
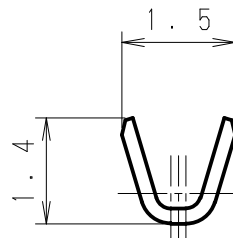
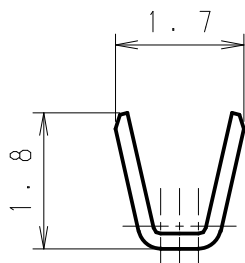
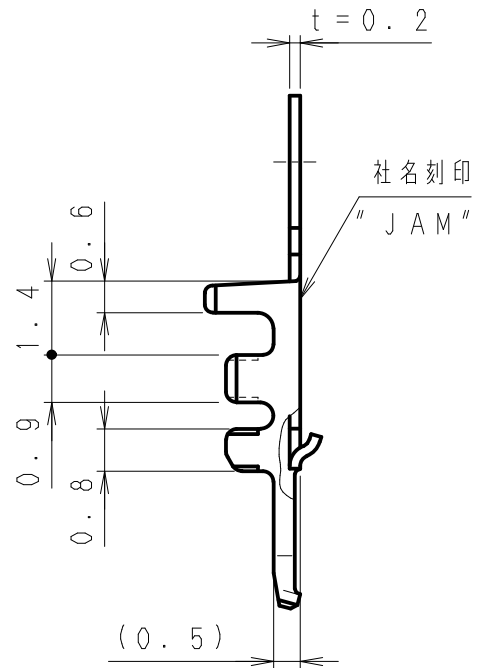
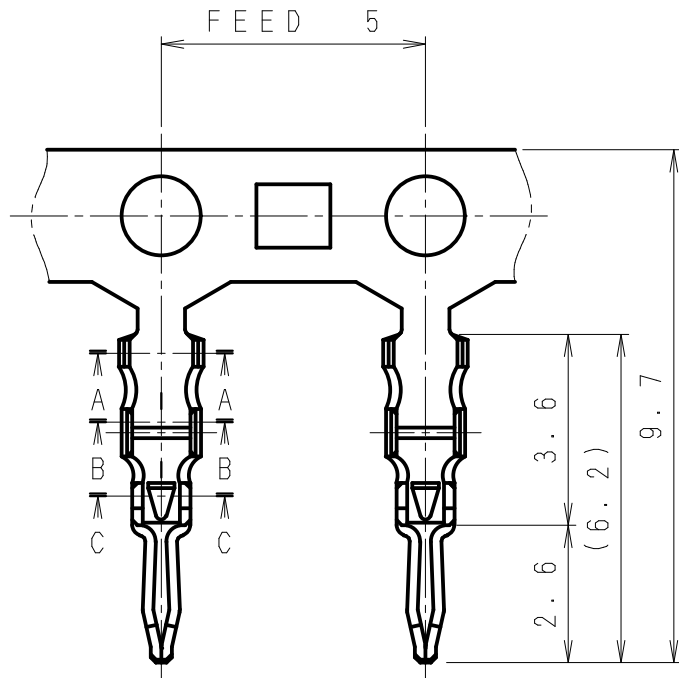

Sec A-A scale 10/1

Sec B-B scale 10/1

Sec C-C scale 10/1

△6	. .								
△5	. .								
△4	. .				507110-2MA	黄銅 Brass	錫鍍金材 Pre-tin Plated	AWG#28~30 MAX φ1.0	
△3	. .				製品番号 PRODUCT No.	材 料 MATERIAL	表面処理 FINISH	通用電線 WIRE SIZE	
△2	. .							被覆外径 INSULATION DIA	
△1	. .								
記号 No.	年月日 DATE	変更記事 REVISION RECORD	設計 DESIGN	承認 APP	製品名 NAME			JZコネクタ ターミナル JZ Connector terminal	
承認 APPROVED	確認 CHECKED		一般公差 TOLERANCE		尺度 SCALE	図番 DRAWING No.			
Y. Horiuchi	K. Koizumi		±0.3		7 / 1	JC-0114-09			
設計 DESIGN	製図 DRAWING		 JAPAN AUTOMATIC MACHINE CO., LTD.						
N. Yarimizu	N. Yarimizu								

第三角法  
3rd ANGLE PROJECTION

単位: mm  
UNIT: mm  
注) . . . . . 図面を実測しないこと  
NOTES) . . . . . DO NOT SCALE

図番 DRAWING No.  
JC-0393-02Z

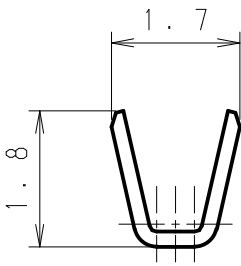
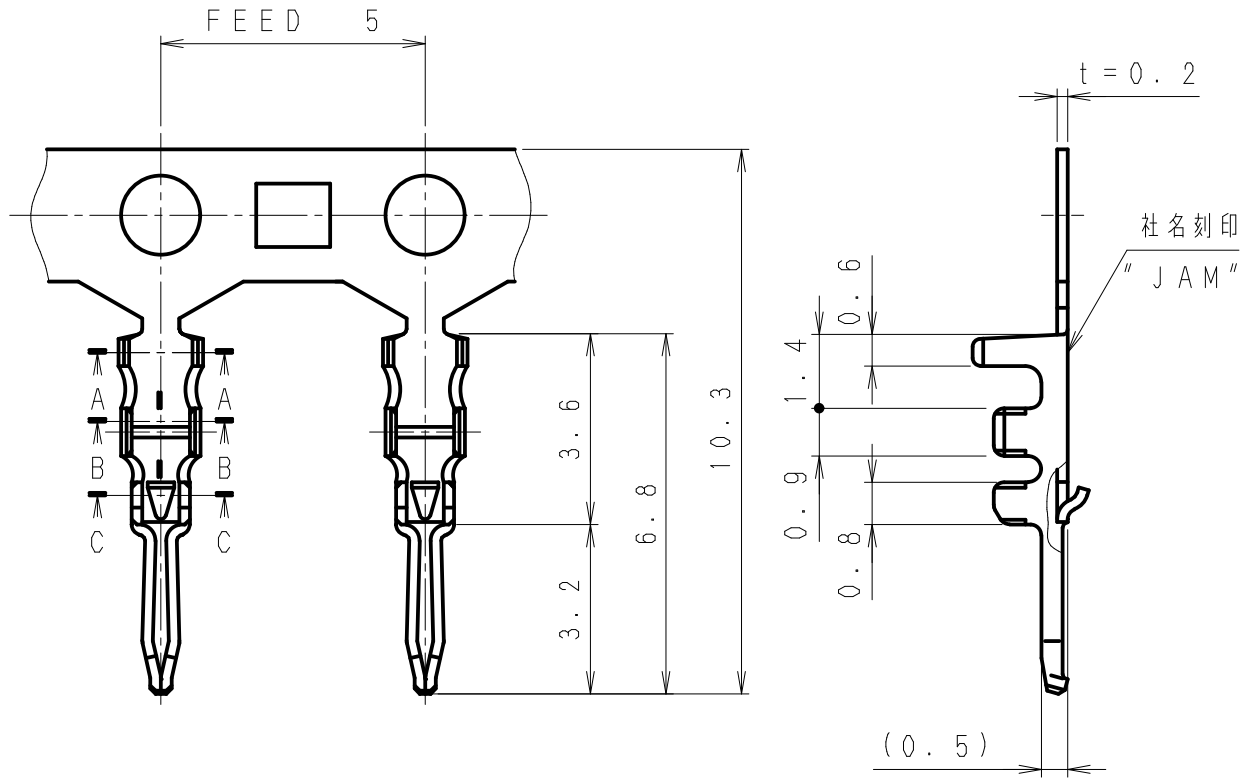

Sec A-A scale 10/1

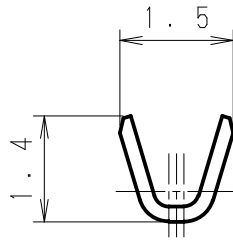

Sec B-B scale 10/1

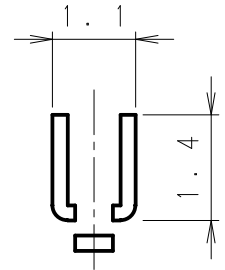

Sec C-C scale 10/1

△6	. .							
△5	. .							
△4	. .				507130-2MA	黄銅 Brass	錫鍍金材 Pre-tin Plated	AWG#28~30 MAX φ1.0
△3	. .				製品番号 PRODUCT No.	材 料 MATERIAL	表面処理 FINISH	適用電線 WIRE SIZE
△2	. .							被覆外径 INSULATION DIA
△1	. .							
記号 No.	年月日 DATE	変更記事 REVISION RECORD	設計 DESIGN	承認 APP	製品名 NAME			JZコネクタ ターミナル JZ Connector terminal
承認 APPROVED	確認 CHECKED		一般公差 TOLERANCE		尺度 SCALE	図番 DRAWING No.		
K. Kusano	A. Kumakura		±0.3		7/1	JC-0393-02Z		
設計 DESIGN	製図 DRAWING							
Y. Shimizu	Y. Shimizu							