

御中

製品仕様書  
Product specifications

製品名 Product Name	RMHコネクタ RMH connector	
製品番号 Product Number	ピンコンタクト Pin contact	725411-2MAC
	ソケットコンタクト Socket contact	725412-2MAC
	リセハウジング REC Housing	RMH25-□□MP※
	プラグハウジング PLUG Housing	SMH25-□□HG※
	リテーナ Retainer	RM25-□□S

受領印欄  
Acknowledged

日本オートマチックマシン株式会社  
電子部品事業部 製品技術G  
〒146-0092 東京都大田区下丸子3-28-4  
TEL 03(3756)1435

JAPAN AUTOMATIC MACHINE CO., LTD  
Product Engineering Group Electronic Parts Headquarters  
3-28-4, Shimomaruko, Ota-ku, Tokyo 146-0092, Japan

※ RoHS対応品  
This product corresponds to RoHS.

## &lt;変更履歴表&gt; ALTERATION HISTORY RECORDS

履歴 Revision	日付 Date	変更内容 Contents of Alteration	変 更 Change	承 認 Approved
制定 Issue	2020. 7.22	—	大垣	小泉
△				
△				
△				
△				
△				
△				
△				
△				
△				
△				
△				
△				
△				

## &lt;目次&gt; INDEX

1. 適用範囲 (Scope)
2. 製品名・製品番号 (Product name and number)
3. 形状・寸法・材料 (Geometry and materials)
4. 定格 (Rated values)
5. 性能 (Performances)
6. 梱包・表示 (Packing and marking)
7. 品番構成 (Product No. code)

## 仕 様 書 Specifications

SA-1460S1-Z0-3/14

## 1. 適用範囲 (Scope)

この製品仕様書は「RMHコネクタ」の一般仕様及び性能について規定する。  
The present document concerns general specifications and performances of  
"RMH connector".

## 2. 製品名・製品番号 (Product name and number)

製品名 Product Name	製品番号 Number	材料及び表面処理 Material and surface treatment
ピンコンタクト Pin contact	7 2 5 4 1 1 - 2 MAC	リン青銅系 スズメッキ材 Phosphor bronze type, Pre-tin Plated
ソケットコンタクト Socket contact	7 2 5 4 1 2 - 2 MAC	リン青銅 スズメッキ材 Phosphor bronze, Pre-tin Plated
リセハウジング Receptacle housing	RMH 2 5 - □ □ MP ※	6 6 ナイロン (UL94V-0) 66 nylon (UL94V-0)
プラグハウジング Plug housing	SMH 2 5 - □ □ HG ※	
リテーナ Retainer	RM 2 5 - □ □ S	P B T (UL94V-0) G F 入り PBT (UL94V-0) with GF

## 3. 形状・寸法・材料 (Geometry and materials)

添付図面による。Refer to attached drawings.

図面番号 Drawing No.	製品名 Product name	記号 Mark
J C - 0 9 1 5 - 4 3	RMHコネクタ 2 P RMH connector 2P	0
J C - 0 9 1 5 - 4 4	RMHコネクタ 3 P RMH connector 3P	0
J C - 0 9 1 5 - 4 5	RMHコネクタ 4 P RMH connector 4P	0
J C - 0 9 1 5 - 4 6	RMHコネクタ 5 ~ 7 P RMH connector 5~7P	0
J C - 0 9 1 5 - 4 7	RMHコネクタ 8 ~ 1 3 P RMH connector 8~13P	0
J C - 0 9 1 5 - 1 1 Z	R E Cハウジング 2 P REC housing 2P	0
J C - 0 9 1 5 - 1 2 Z	R E Cハウジング 3 P REC housing 3P	0
J C - 0 9 1 5 - 1 3 Z	R E Cハウジング 4 P REC housing 4P	0
J C - 0 9 1 5 - 1 4 Z	R E Cハウジング 5 ~ 7 P REC housing 5~7P	0
J C - 0 9 1 5 - 1 5 Z	R E Cハウジング 8 ~ 1 3 P REC housing 8~13P	0
J C - 0 9 1 5 - 2 6	P L U Gハウジング 2 P PLUG housing 2P	0

図面番号 Drawing No.	製品名 Product name	記号 Mark
J C - 0 9 1 5 - 2 7	P L U Gハウジング 3 P PLUG housing 3P	0
J C - 0 9 1 5 - 2 8	P L U Gハウジング 4 ~ 7 P PLUG housing 4~7P	0
J C - 0 9 1 5 - 2 9	P L U Gハウジング 8 ~ 1 3 P PLUG housing 8~13P	0
J C - 0 9 1 5 - 3 0	リテーナ Retainer	0
J C - 0 6 2 2 - 0 6 Z	ピンコンタクト Pin contact	△
J C - 0 6 2 2 - 1 5 Z	ソケットコンタクト Socket contact	0
J C - 0 9 1 5 - 1 6 Z	RMHコネクタ用取付パネル寸法 RMH Connector attachment panel size	0

## 4. 定格 (Rated values)

項目 Item	規格値 Description
定格電圧 Rated voltage	2 5 0 V A C . D C
定格電流 (注1) Rated current (Note 1)	3 A
使用温度範囲 Temperature range	- 4 0 ~ + 8 5 ° C (通電による温度上昇分を含む) -40 to +85°C (heating by energization included)
適用電線範囲 (注2) Wire size (Note 2)	AWG # 2 2 ~ # 2 8 最大被覆外径 $\phi$ 1.7 mm AWG #22 to #28 Maximum diameter of insulation covering $\phi$ 1.7 mm
保存温度 Storage temperature	- 3 0 ~ + 6 0 ° C (90% RH以下) -30 to +60°C (90% RH or less)

(注1) 定格電流はコンタクト接触部の定格値であり、実使用においては使用電線の定格電流、使用温度により決定される。

(注2) 電線はより線を使用し、単線等の特殊電線は原則として使用出来ません。

(Note 1) The rated current shown is at the contact section. Practically, it varies depending on rated current of particular wire and operating temperature.

(Note 2) Use a stranded wire. Do not use solid or other special wires.

## 5. 性能 (Performances)

性能は、下表に示す試験条件及び方法で試験を実施したとき、各項目に規定する規格値を満足すること。尚、試験は特に指定のない限り JIS C 60068-1 [環境試験方法 (電気、電子)通則] に規定された試験場所の標準にて実施する。

The performances tested under the conditions and methods given in the table below shall conform to the respective specifications. Unless otherwise specified, carry out the tests according to the standards of a place of test stipulated in IEC 60068-1 "General Rules of Environmental Testing Method (Electric and Electronic)".

## 5-1 外観 (Appearance)

No.	項目 Item	規格値 Description	条件 Check
5-1-1	外観 Appearance	使用上有害となる様な割れ・変形等が無いこと Crack, deformation, etc. harmful in use are not allowed	目視 Visual

## 5-2 機械的性能 (Mechanical properties)

No.	項目 Item	規格値 Description	試験条件及び方法 Check
5-2-1	挿入力 Insertion force	別表A参照 See Appended Table A	コンタクトを各々のハウジングに装着し、リセハウジングへのプラグハウジング挿入力を測定する。 試験速度 25mm/min  Inserting the contact into each housing, measure the force required for inserting the PLUG housing into REC housing at 25 mm/min.
5-2-2	保持力 Pull-out force	別表A参照 See Appended Table A	コンタクトを各々のハウジングに装着し、ロックを除去してリセハウジングとの保持力を測定する。 試験速度 25mm/min  Inserting the contact into each housing, unlock the housing, and measure the pull-out force of REC housing at 25 mm/min.
5-2-3	ハウジングロック保持力 Housing locking power	29.4 N以上 29.4 N or more	コンタクトを挿入しない状態で、リセハウジングとプラグハウジングを嵌合させ、プラグハウジングを引張り、ロックが外れるときの力を測定する。 試験速度 100mm/min  Contact is not inserted, engage the REC housing and plug housing with each other, and pull the PLUG housing at 100 mm/min until unlocked. Take the reading at this point.

No.	項目 Item	規格値 Description		試験条件及び方法 Check
5-2-4	圧着部引張強度 Tensile strength of crimped section	電線 Wire size	強度 N 以上 Minimum strength in N	コンタクトのワイヤバレルと電線導体を圧着し、治具で固定し電線の軸方向に引っ張る。 試験速度 25mm/min Crimp the contact's wire barrel and conductor together, fasten the altogether, and pull the wire axially at 25 mm/min.
		AWG#22	4 4.1	
		AWG#24	2 9.4	
		AWG#26	1 9.6	
		AWG#28	9.8	
		AWG#30	4.9	
5-2-5	コンタクト 挿入力 Contact insertion force	6.9 N 以下 6.9 N or less		コンタクトをハウジングに挿入するのに要する力を万能試験機を用いて測定する。 試験速度 25mm/min Using universal testing machine, measure the force required for inserting the contact into housing at 25 mm/min.
5-2-6	コンタクト 保持力 Contact pull-out force	9.8 N 以上 9.8 N or more		ハウジングに装着したコンタクトを軸方向に引っ張り、ハウジングからコンタクトが離脱するときの荷重を万能試験機を用いて測定する。 試験速度 25mm/min Using universal testing machine, pull the contact axially at 25 mm/min until it leaves the housing. Take the reading at this point.
5-2-7	リテーナ 挿入力 Retainer Insertion force	1 9.6 N以下 19.6 N or less		ターミナルを挿入後、リテーナを挿入するのに要する力を万能試験機を用いて測定する。 試験速度 25mm/min Using universal testing machine, measure the force required for inserting the retainer into housing at 25 mm/min

## 5-3 電気的性能 (Electrical characteristics)

No.	項目 Item	規格値 Description	試験条件及び方法 Check
5-3-1	接触抵抗 Contact resistance	初期 10 mΩ 以下 10 mΩ or less initially	コネクタを嵌合状態にして電気抵抗を測定し、電線抵抗を差し引いて接触抵抗とする。 試験電流 15mA (20mV以下) Engage the connector, measure the overall resistance at 15 mA and 20 mV or less and, from the reading, subtract the wire resistance. Retain the difference as contact resistance.
5-3-2	絶縁抵抗 Insulation resistance	1000 MΩ 以上 1000 MΩ or more	コネクタ外面とコンタクト相互間及び隣接するコンタクト間にDC500Vを印可して測定する。 Apply 500 V DC between connector housing and each of contacts, and between adjacent contacts.
5-3-3	耐電圧 Dielectric strength	AC 1000 V / 1分間 異常なきこと AC 1000V / 1min. Shall remain normal	ハウジング外面とコンタクト相互間及び隣接するコンタクト間にて測定する。 Apply 1000 V AC for 1 min between connector housing and each of contacts, and between adjacent contacts.
5-3-4	温度上昇 Temperature rise	30 K 以下 (適用最大電線による) 30 K or less (With thickest applicable wire)	ハウジングの全極にコンタクトを装着し、嵌合させて各コンタクトを直列に接続し、最大定格電流を通電した時のコンタクト部の温度上昇を測定する。 Mount the contacts on all housing poles, engage them, connect all contacts in series, apply rated current, and measure the temperature at contacts.

## 5-4 耐久環境性能 (Durability)

No.	項目 Item	規格値 Description		試験条件及び方法 Check
5-4-1	挿抜寿命 Engagement and disengagement	接触抵抗 Contact resistance	20 mΩ 以下 20 mΩ or less	ハウジングにコンタクトを装着し、RECハウジングにPLUGハウジングを挿抜(30回)試験前後の接触抵抗を測定する。  Mount the contacts on housing, Repeat 30 cycles of insertion and removal of REC housing and PLUG housing, and measure the contact resistance.
		外観 Appearance	異常なきこと Shall remain normal	
5-4-2	耐振動性 Vibration	接触抵抗 Contact resistance	20 mΩ 以下 20 mΩ or less	コネクタを結合し、下記条件にて振動試験実施。 掃引割合 10~55~10Hz 掃引時間 1分 最大振幅 1.5 mm 振動軸方向 X、Y、Z 振動時間 各2時間=6時間  Engage the connector, and carry out tests under following conditions. Sweep frequency 10-55-10 Hz. Sweep time 1 min. Maximum amplitude 1.5 mm. Vibration axes X, Y, Z. Vibration time 2 h each or totally 6 h.
		電流瞬断 Momentary failure	1 μs 以下 1 μ sec or less	
		外観 Appearance	異常なきこと Shall remain normal	
5-4-3	耐熱性 Heating	接触抵抗 Contact resistance	20 mΩ 以下 20 mΩ or less	コネクタを結合後、下記条件に放置 雰囲気温度 100 ± 5℃ 放置時間 240時間 室内で1~2時間放置後測定  Engage the connector, and keep the sample for 240 h under following conditions. Ambient temperature 100 ± 5°C. Leave the sample at the room for 1 to 2 h before check.
		外観 Appearance	異常なきこと Shall remain normal	
5-4-4	耐寒性 Cold	接触抵抗 Contact resistance	20 mΩ 以下 20 mΩ or less	コネクタを結合後、下記条件に放置 雰囲気温度 -40 ± 3℃ 放置時間 240時間 室内で1~2時間放置後測定  Engage the connector, and keep the sample for 240 h under following conditions. Ambient temperature -40 ± 3°C. Leave the sample at the room for 1 to 2 h before check.
		外観 Appearance	異常なきこと Shall remain normal	



No.	項目 Item	規格値 Description		試験条件及び方法 Check
5-4-5	耐熱衝撃性 Heat shock	接触抵抗 Contact resistance	20 mΩ 以下 20 mΩ or less	コネクタを結合後、下記条件に放置 1. 低温側 $-40 \pm 2^{\circ}\text{C}$ 30分 2. 室温 $+25 \pm 10^{\circ}\text{C}$ 10分 3. 高温側 $+85 \pm 2^{\circ}\text{C}$ 30分 4. 室温 $+25 \pm 10^{\circ}\text{C}$ 10分 1～4を25サイクル行う。  Engage the connector, and subject it to 25 cycles of following sequence. 1. Low temperature $-40 \pm 2^{\circ}\text{C}$ for 30 min. 2. Room temperature $+25 \pm 10^{\circ}\text{C}$ within 10 min. 3. High temperature $+85 \pm 2^{\circ}\text{C}$ for 30 min. 4. Room temperature $+25 \pm 10^{\circ}\text{C}$ within 10 min.
		外観 Appearance	異常なきこと Shall remain normal	
5-4-6	耐湿性 Moisture	接触抵抗 Contact resistance	20 mΩ 以下 20 mΩ or less	コネクタを結合後、下記条件に放置 雰囲気温度 $60 \pm 2^{\circ}\text{C}$ 相対湿度 90～95% RH 放置時間 240時間 1～2時間放置後測定  Engage the connector, and keep the sample for 240 h under following conditions. Ambient temperature $60 \pm 2^{\circ}\text{C}$ . Relative humidity 90 to 95%. Leave the sample for 1 to 2 h before check.
		絶縁抵抗 Insulation resistance	500MΩ 以上 500 MΩ or more	
		耐電圧 Dielectric strength	AC500V/ 1分間 異常なきこと Shall remain normal at 500 V AC for 1 min	
		外観 Appearance	異常なきこと Shall remain normal	

No.	項目 Item	規格値 Description		試験条件及び方法 Check
5-4-7	耐塩水噴霧性 Salt mist	接触抵抗 Contact resistance	20 mΩ 以下 20 mΩ or less	コネクタを結合後、下記条件に放置 温 度 35 ± 2℃ 塩水濃度 5 ± 1% (重量比) 噴霧時間 48時間 接触抵抗測定は、水洗をし室温で乾燥 させてから、1～2時間放置後測定。  Engage the connector, and keep the sample under following conditions. Temperature 35 ± 2°C. Salt concentration 5 ± 1%wt. Spray time 48 h. Then, rinse the sample, and leave it dry at room temperature for 1 to 2 h.
		外観 Appearance	異常なきこと Shall remain normal	
5-4-8	耐硫化水素ガス性 Hydrogen sulfide	接触抵抗 Contact resistance	20 mΩ 以下 20 mΩ or less	コネクタを結合後、下記硫化水素ガス 中に放置。 濃 度 3 ± 1 ppm 温 度 40 ± 2℃ 放置時間 96時間 室内で1～2時間放置後測定。  Engage the connector, and keep it in hydrogen sulfide for 96 h. Density 3 ± 1 ppm. Temperature 40 ± 2°C. Leave the sample at the room for 1 to 2 h before check.
		外観 Appearance	異常なきこと Shall remain normal	
5-4-9	耐アンモニア性 Ammonia	接触抵抗 Contact resistance	20 mΩ 以下 20 mΩ or less	コネクタを結合後、下記アンモニア水 の入ったデシケータ容器中に放置 濃度 28% 温度 25℃ 容積比 25 ml / ℓ 放置時間 40分 1～2時間放置後測定。  Engage the connector, and keep it in desiccator filled with following aqueous ammonia for 40 min. Concentration 28%. Temperature 25°C. Volume ratio 25 ml / ℓ Leave the sample for 1 to 2 h before check.
		外観 Appearance	ターミナル 各部に割れ ・ヒビの発 生なきこと Terminals shall remain free from scores and cracks	

6. 梱包・表示 (Packing and marking)

6-1 コンタクト (Contacts)

コンタクトはリールに巻き、さらにダンボール箱に梱包して出荷。  
表示はリールに型番、数量、ロットNo.を明記したラベルを貼り付ける。  
Wind the contacts on reel, and pack it in cardboard case for shipment.  
As indications, attach a label filled with product number, quantity and lot No. onto reel.

6-2ハウジング、リテーナ (Housings, Retainer)

ナイロン袋に入れ、さらに、ダンボール箱に梱包して出荷。  
表示はナイロン袋、ダンボール箱に型番、数量、ロットNo.を明記したラベルを貼り付ける。  
Put the housings in nylon bag, and pack it in cardboard case for shipment.  
As indications, attach labels filled with product number, quantity and lot No. onto nylon bag and cardboard case.

・ラベル Label

① 製品番号 (Product No.)

② ロット番号 (Lot No.)

0 A 7 L 1 8 1 0 0 1

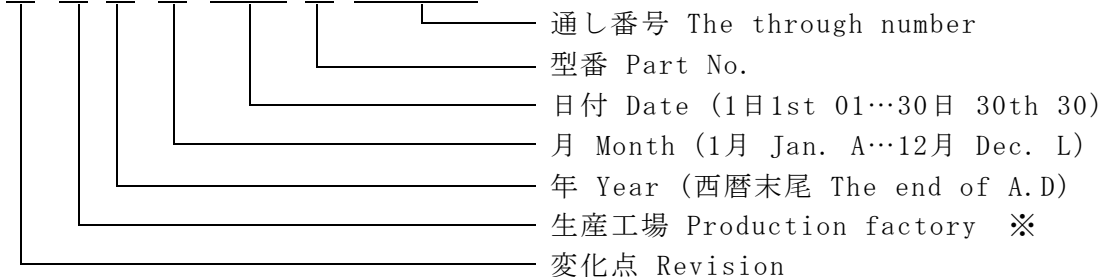

※生産工場：A：日本オートマチックマシン（株） 端子事業所（福島県 南相馬市）  
Production factory：

A：JAPAN AUTOMATIC MACHINE CO.,LTD TANSHI PLANT (Minamisoma, Fukushima)

③ 数量 (Quantity)

④ 原産国 Country of origin：日本 (Japan)

## 7. 品番構成 (Product No. code)

## 7-1 コンタクト (Contact)

7 2 5 4 1 □ - 2 M A C

材質種別記号 (Material)

紙巻き (Paper winding)

スズメッキ材 (Pre-tin Plated)

シリーズNo. (Series No.)

7 2 5 4 1 1 : ピンコンタクト (Pin contact)

7 2 5 4 1 2 : ソケットコンタクト (Socket contact)

## 7-2 リセハウジング (REC Housing)

RMH 2 5 - □ □ MP ※※

色記号 (Color)

製品種別 (Product type)

MP : リセハウジング (REC housing)

極数 (Poles)

2 : 2 極 (2: 2 poles)

} }

1 3 : 1 3 極 (13: 13 poles)

シリーズ名 (Series Name)

## 7-3 プラグハウジング (PLUG Housing)

SMH 2 5 - □ □ HG ※※

色記号 (Color)

製品種別 (Product type)

HG : プラグハウジング (PLUG housing)

極数 (Poles)

2 : 2 極 (2: 2 poles)

} }

1 3 : 1 3 極 (13: 13 poles)

シリーズ名 (Series Name)

7-4 リテーナ (Retainer)

RM25-□□S

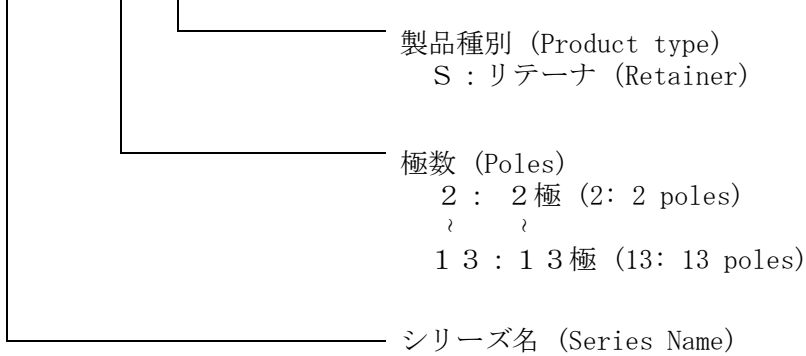

<色記号> <Color>

記号 Symbol	無 None	RE	PK	BR	GY	YG
色 Name	白 White	赤 Red	桃 Pink	紫 Purple	灰 Gray	若草 Yellowish green

記号 Symbol	YL	OR	BW	BL	GR	BK
色 Name	黄 Yellow	橙 Orange	茶 Brown	青 Blue	緑 Green	黒 Black

記号 Symbol	LY	LP	LO
色 Name	蛍光黄 Fluorescence yellow	蛍光桃 Fluorescence pink	蛍光橙 Fluorescence orange

※ JAMでの標準色は白色です。  
\* JAM standard color is white.

【表A】 挿入力及び保持力  
(Table A: Insertion force and pull-out force)

極数 Poles	挿入力(N以下) Maximum insertion force in N	保持力(N以上) Minimum pull-out force in N
2P	19.6	2.35
3P	26.5	3.53
4P	33.3	4.70
5P	40.2	5.88
6P	47.0	7.06
7P	53.9	8.23
8P	60.8	9.41
9P	67.6	10.58
10P	74.5	11.76
11P	81.3	12.94
12P	89.2	14.11
13P	96.0	15.29

製造元 :  
日本オートマチックマシン株式会社

Manufacturer :  
JAPAN AUTOMATIC MACHINE CO., LTD.

第三角法  
3rd ANGLE PROJECTION

単位: mm 注) . . . . 図面を実測しないこと  
UNIT: mm NOTES) . . . . DO NOT SCALE

図番 DRAWING No.  
JC-0915-43

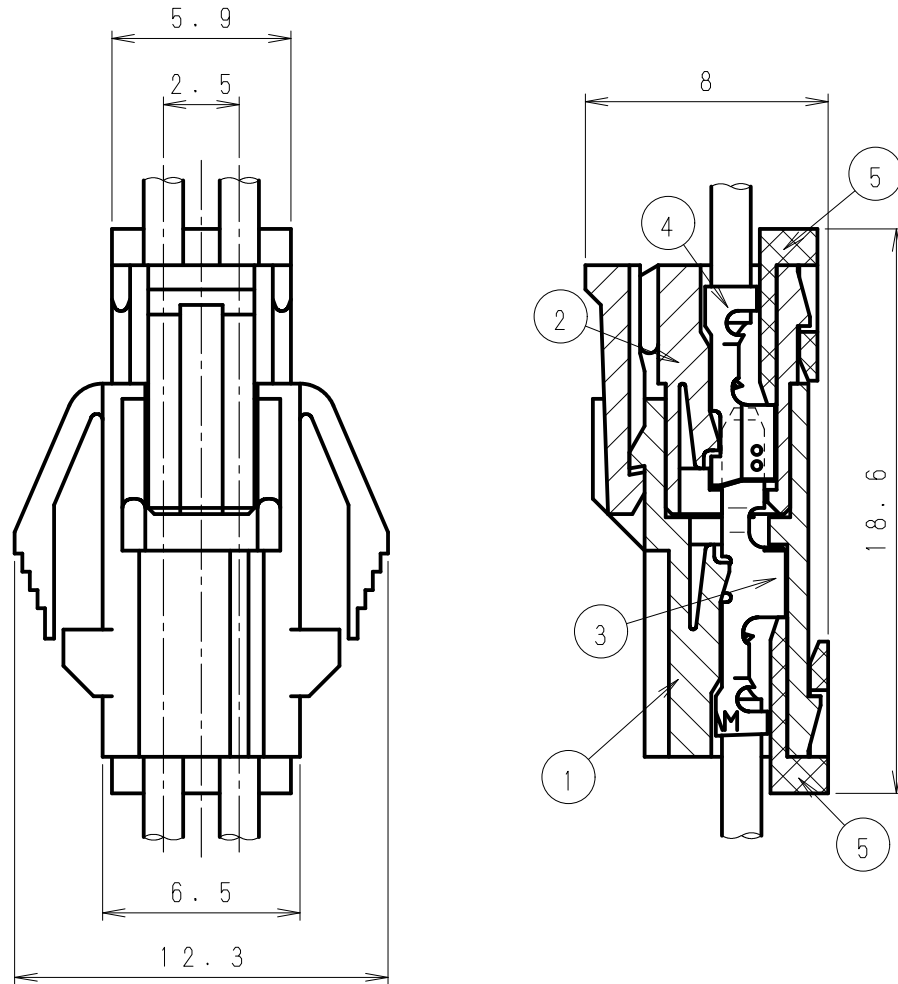

No.	製品番号	製品名	材質
①	RMH25-02MP	リセハウジング REC housing	66ナイロン 66 Nylon
②	SMH25-02HG	プラグハウジング PLUG housing	
③	725411-2MAC	ピンコンタクト Pin contact	リン青銅系 (スズメッキ材) Phosphor Bronze (Pre-tin Plated)
④	725412-2MAC	ソケットコンタクト Socket contact	リン青銅 (スズメッキ材) Phosphor Bronze (Pre-tin Plated)
⑤	RM25-02S	リテーナ Retainer	PBT (UL94V-0) GF入り PBT (UL94V-0) With GF

極数 Poles	2
適用電線 Wire	AWG#22~#28
被覆外径 Ins. Wire	MAXφ1.7mm

△4	. .									
△3	. .									
△2	. .				製品番号 PRODUCT No.	No.	材 料 MATERIAL	表面処理 FINISH	適用電線 WIRE SIZE	被覆外径 INSULATION DIA
△1	. .									
記号 No.	年月日 DATE	変更記事 REVISION RECORD	設計 DESIGN	承認 APP	製品名 NAME		RMHコネクタ 2P RMH Connector 2P			
承認 APPROVED	確認 CHECKED		一般公差 TOLERANCE		尺度 SCALE	図番 DRAWING No.				
K. Koizumi		A. Kumakura		±0.3		4 / 1		JC-0915-43		
設計 DESIGN		製図 DRAWING								
N. Ogaki		N. Ogaki								

第三角法  
3rd ANGLE PROJECTION

単位: mm 注) . . . . 図面を実測しないこと  
UNIT: mm NOTES) . . . . DO NOT SCALE

図番 DRAWING No.  
JC-0915-44

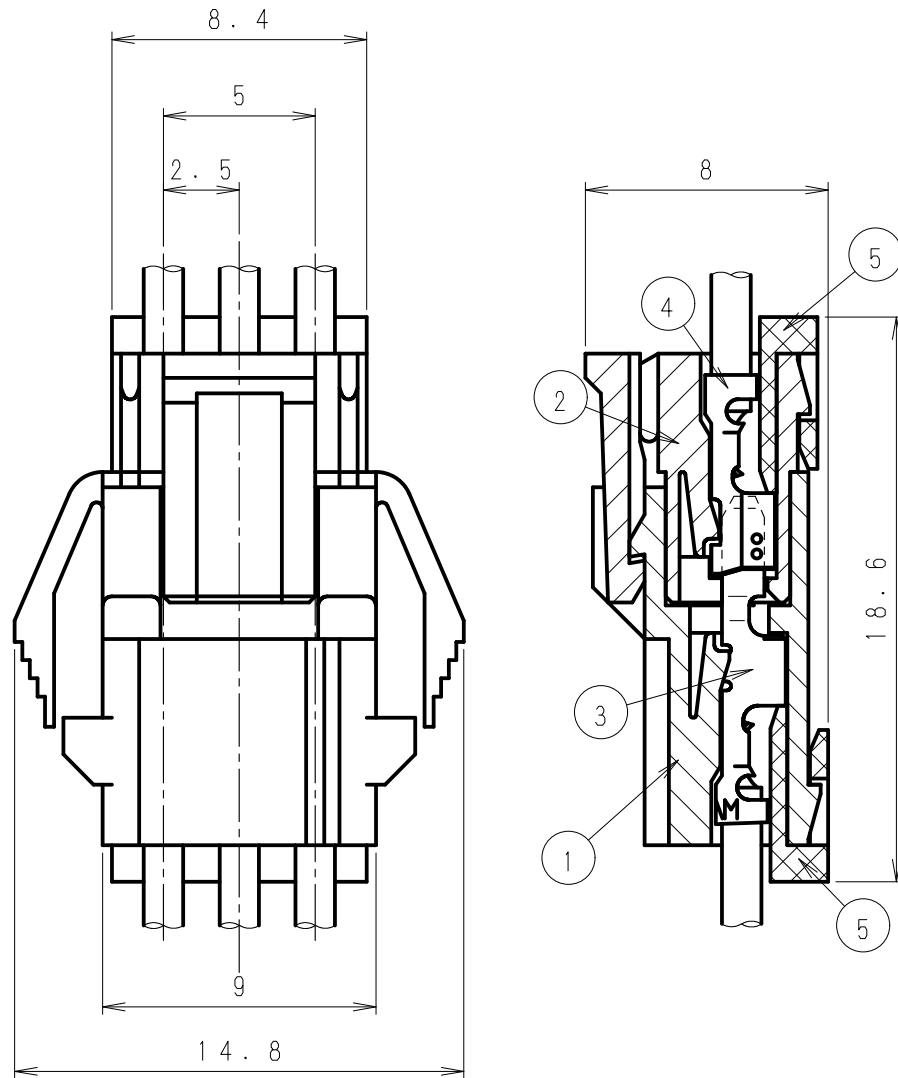

No.	製品番号	製品名	材質
①	RMH25-03MP	リセハウジング REC housing	66ナイロン 66 Nylon
②	SMH25-03HG	プラグハウジング PLUG housing	
③	725411-2MAC	ピンコンタクト Pin contact	リン青銅系 (スズメッキ材) Phosphor Bronze (Pre-tin Plated)
④	725412-2MAC	ソケットコンタクト Socket contact	リン青銅 (スズメッキ材) Phosphor Bronze (Pre-tin Plated)
⑤	RM25-03S	リテーナ Retainer	PBT (UL94V-0) GF入り PBT (UL94V-0) With GF

極数 Poles	3
適用電線 Wire	AWG#22~#28
被覆外径 Insu. Wire	MAXφ1.7mm

△4	. .										
△3	. .										
△2	. .										
△1	. .										
記号 No.	年月日 DATE	変更記事 REVISION RECORD	設計 DESIGN	承認 APP	製品番号 PRODUCT No.	No.	材料 MATERIAL	表面処理 FINISH	適用電線 WIRE SIZE	被覆外径 INSULATION DIA	
承認 APPROVED	K. Koizumi	確認 CHECKED	A. Kumakura	一般公差 TOLERANCE	±0.3	尺度 SCALE	4/1	製品名 NAME	RMHコネクタ 3P RMH Connector 3P	図番 DRAWING No.	JC-0915-44
設計 DESIGN	N. Ogaki	製図 DRAWING	N. Ogaki	<b>JAPAN AUTOMATIC MACHINE CO., LTD.</b>							





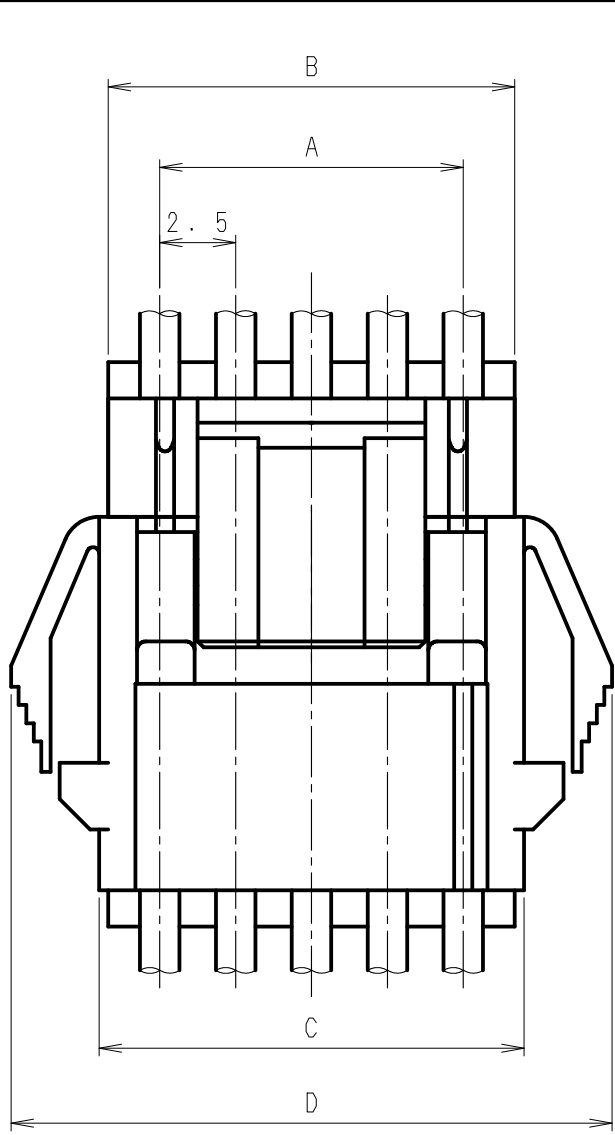

極数 Poles	A	B	C	D
5	10.0	13.4	14.0	19.8
6	12.5	15.9	16.5	22.3
7	15.0	18.4	19.0	24.8

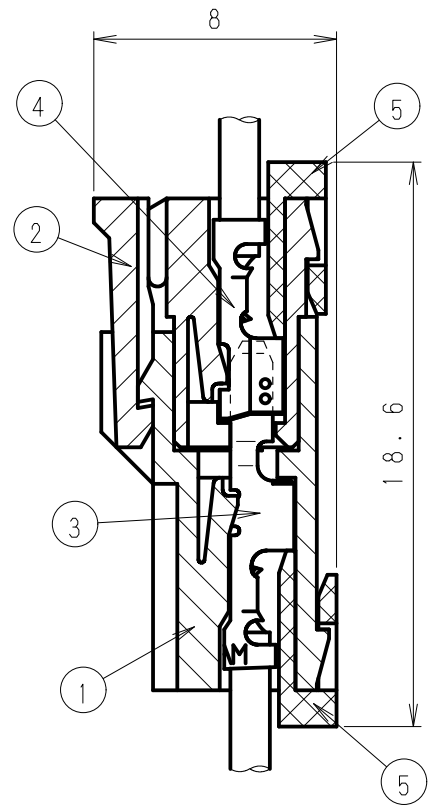

No.	製品番号 Product No.	製品名 Product name	材質 Material
①	RMH25-□□MP	リセハウジング REC housing	66ナイロン 66Nylon
②	SMH25-□□HG	プラグハウジング PLUG housing	
③	725411-2MAC	ピンコンタクト Pin contact	リン青銅系 (スズメッキ材) Phosphor Bronze type (Pre-tin Plated)
④	725412-2MAC	ソケットコンタクト Socket contact	リン青銅 (スズメッキ材) Phosphor Bronze (Pre-tin Plated)
⑤	RM25-□□S	リテーナ Retainer	PBT (UL94V-0) GF入り PBT (UL94V-0) With GF

極数 Poles	5~7
適用電線 Wire	AWG#22~#28
被覆外径 Insu. Wire	MAXφ1.7mm

△4	. .									
△3	. .									
△2	. .									
△1	. .									
記号 No.	年月日 DATE	変更記事 REVISION RECORD	設計 DESIGN	承認 APP	製品番号 PRODUCT No.	No.	材 料 MATERIAL	表面処理 FINISH	適用電線 WIRE SIZE	被覆外径 INSULATION DIA
承認 APPROVED	承認 CHECKED		一般公差 TOLERANCE		尺度 SCALE		製品名 NAME			
K. Koizumi	A. Kumakura		±0.3		4 / 1		RMHコネクタ 5~7P RMH Connector 5~7P			
設計 DESIGN	製図 DRAWING									
N. Ogaki	N. Ogaki									

第三角法  
3rd ANGLE PROJECTION

単位: mm 注) . . . . 図面を実測しないこと  
UNIT: mm NOTES) . . . . DO NOT SCALE

図番 DRAWING No.  
JC-0915-47

極数 Poles	A	B	C	D
8	17.5	20.9	21.5	27.3
9	20.0	23.4	24.0	29.8
10	22.5	25.9	26.5	32.3
11	25.0	28.4	29.0	34.8
12	27.5	30.9	31.5	37.3
13	30.0	33.4	34.0	39.8

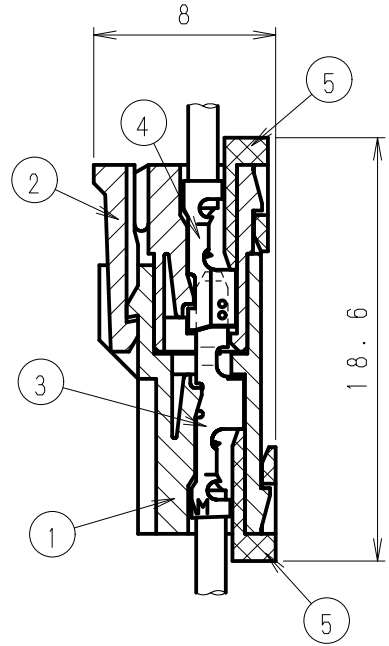
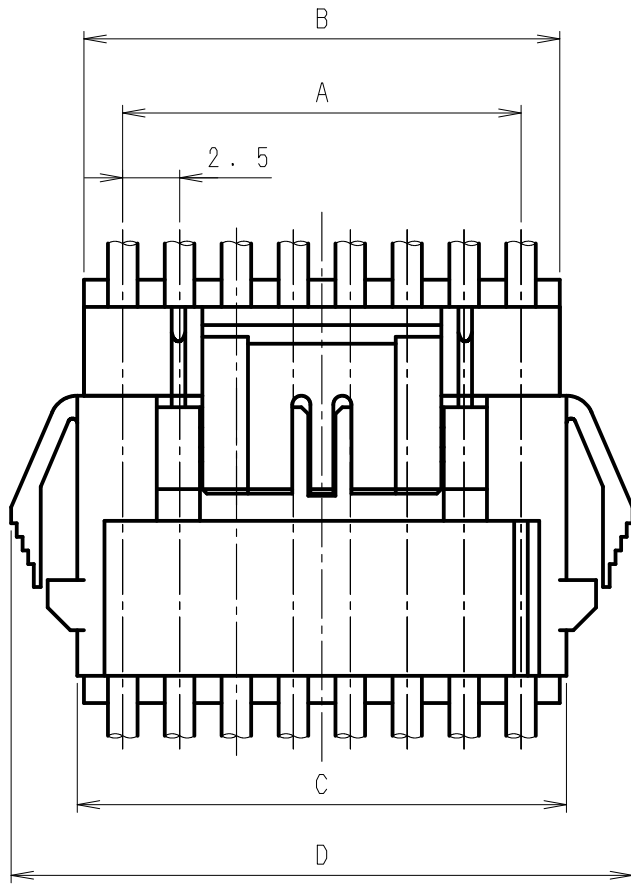

No.	製品番号 Product No.	製品名 Product name	材質 Material
①	RMH25-□□MP	リセハウジング REC housing	66ナイロン 66Nylon
②	SMH25-□□HG	プラグハウジング PLUG housing	
③	725411-2MAC	ピンコンタクト Pin contact	リン青銅系 (スズメッキ材) Phosphor Bronze type (Pre-tin Plated)
④	725412-2MAC	ソケットコンタクト Socket contact	リン青銅 (スズメッキ材) Phosphor Bronze (Pre-tin Plated)
⑤	RM25-□□S	リテーナ Retainer	PBT (UL94V-0) GF入り PBT (UL94V-0) With GF

極数 Poles	8~13
適用電線 Wire	AWG#22~#28
被覆外径 Insu. Wire	MAXφ1.7mm

△4	. .										
△3	. .										
△2	. .										
△1	. .										
記号 No.	年月日 DATE	変更記事 REVISION RECORD	設計 DESIGN	承認 APP	製品番号 PRODUCT No.	No.	材 料 MATERIAL	表面処理 FINISH	適用電線 WIRE SIZE	被覆外径 INSULATION DIA	
承認 APPROVED	K. Koizumi	確認 CHECKED	A. Kumakura	一般公差 TOLERANCE	±0.3	尺度 SCALE	3 / 1	図番 DRAWING No.	JC-0915-47	製品名 NAME	RMHコネクタ 8~13P RMH Connector 8~13P
設計 DESIGN	N. Ogaki	製図 DRAWING	N. Ogaki	JAPAN AUTOMATIC MACHINE CO., LTD.							

第三角法  
3rd ANGLE PROJECTION

単位: mm 注) . . . . 図面を実測しないこと  
UNIT: mm NOTES) . . . . DO NOT SCALE

図番 DRAWING No.  
JC-0915-11Z

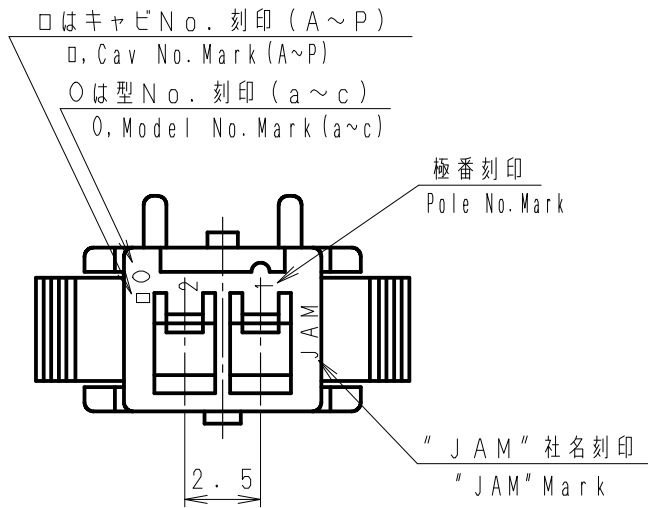
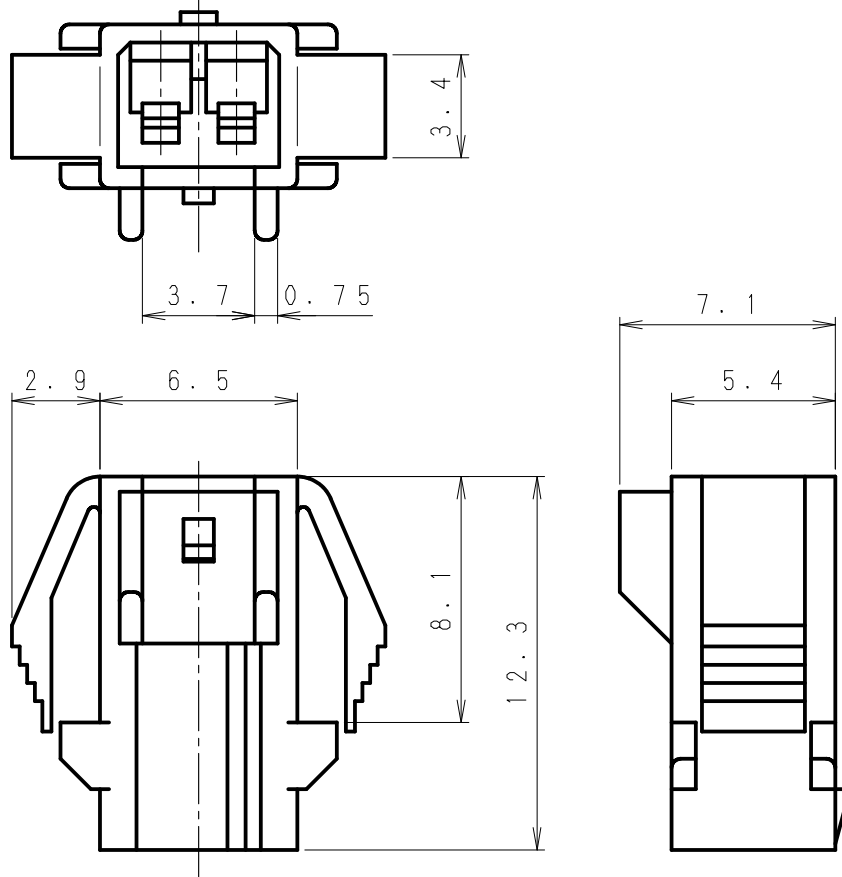

△5	. .							
△4	. .							
△3	. .				RMH25-02MP	66ナイロン 66Nylon	UL94V-0	
△2	. .				製品番号 PRODUCT No.	材 料 MATERIAL	備考 NOTE	色 COLOR
△1	. .							
記号 No.	年月日 DATE	変更記事 REVISION RECORD	設計 DESIGN	承認 APP	製品名 NAME		RECハウジング REC housing	
承認 APPROVED	確認 CHECKED		一般公差 TOLERANCE		尺度 SCALE	図番 DRAWING No.		
K. Koizumi	A. Kumakura		±0.3		4 / 1	JC-0915-11Z		
設計 DESIGN	製図 DRAWING							
N. Ogaki	N. Ogaki							

第三角法  
3rd ANGLE PROJECTION

単位: mm 注) . . . . 図面を実測しないこと  
UNIT: mm NOTES) . . . . DO NOT SCALE

図番 DRAWING No.  
JC-0915-12Z

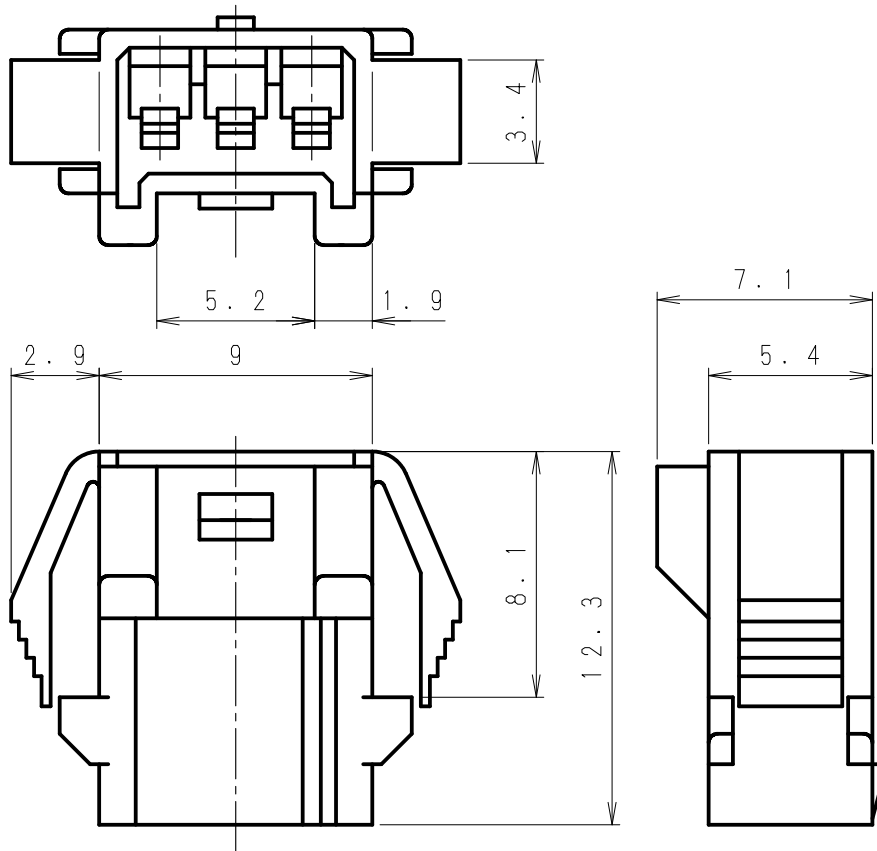

□はキャビNo. 刻印 (A~P)  
□, Cav No. Mark (A~P)  
○は型No. 刻印 (a~c)  
○, Model No. Mark (a~c)

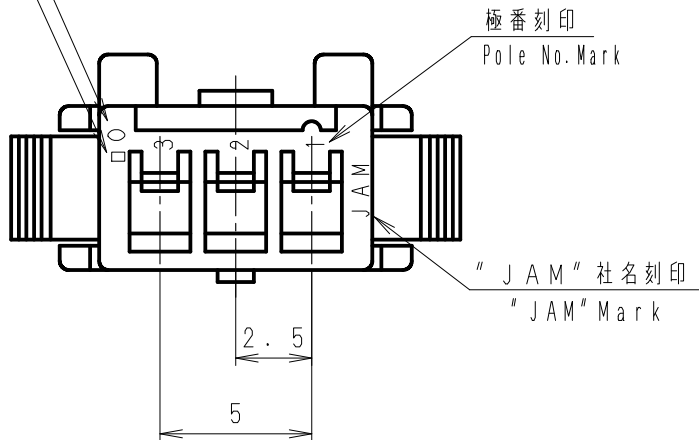

△5	. . .							
△4	. . .							
△3	. . .				RMH25-03MP	66ナイロン 66Nylon	UL94V-0	
△2	. . .				製品番号 PRODUCT No.	材 料 MATERIAL	備考 NOTE	色 COLOR
△1	. . .							
記号 No.	年月日 DATE	変更記事 REVISION RECORD	設計 DESIGN	承認 APP	製品名 NAME		RECハウジング REC housing	
承認 APPROVED	K. Koizumi	確認 CHECKED	A. Kumakura	一般公差 TOLERANCE	±0.3	尺度 SCALE	4/1	図番 DRAWING No.
設計 DESIGN	N. Ogaki	製図 DRAWING	N. Ogaki					

第三角法  
3rd ANGLE PROJECTION

単位: mm 注) . . . . 図面を実測しないこと  
UNIT: mm NOTES) . . . . DO NOT SCALE

図番 DRAWING No.  
JC-0915-13Z

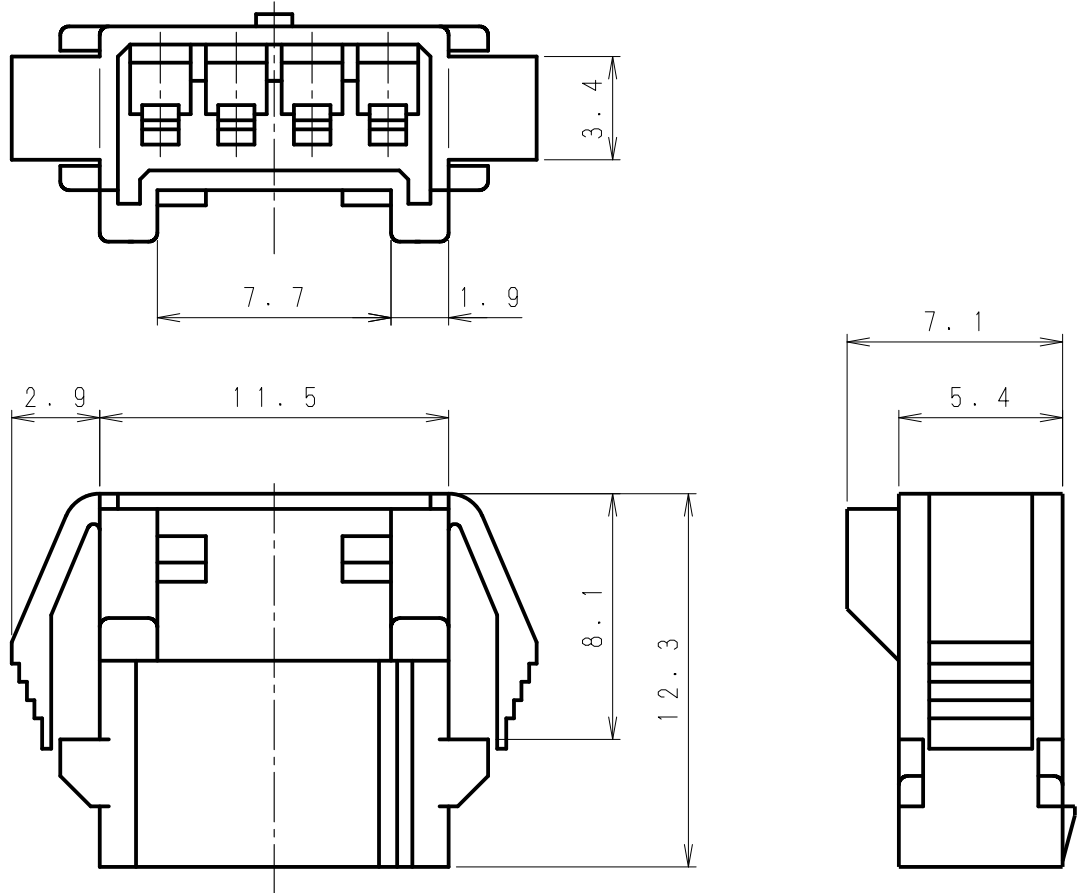

□はキャビNo. 刻印 (A~P)  
□, Cav No. Mark (A~P)  
○は型No. 刻印 (a~c)  
○, Model No. Mark (a~c)

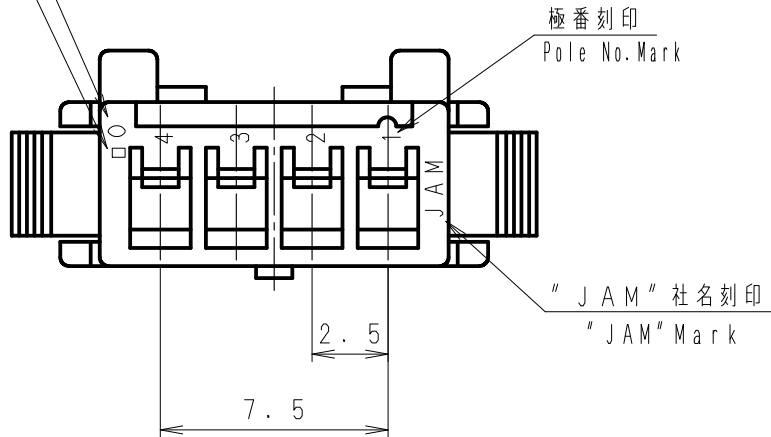

△5	. .							
△4	. .							
△3	. .				RMH25-04MP	66ナイロン 66Nylon	UL94V-0	
△2	. .				製品番号 PRODUCT No.	材 料 MATERIAL	備考 NOTE	色 COLOR
△1	. .							
記号 No.	年月日 DATE	変更記事 REVISION RECORD	設計 DESIGN	承認 APP	製品名 NAME		RECハウジング REC housing	
承認 APPROVED	確認 CHECKED		一般公差 TOLERANCE		尺度 SCALE	図番 DRAWING No.		
K. Koizumi	A. Kumakura		±0.3		4/1	JC-0915-13Z		
設計 DESIGN	製図 DRAWING		 <b>JAPAN AUTOMATIC MACHINE CO., LTD.</b>					
N. Ogaki	N. Ogaki							

製品番号 Product No.	A	B
RMH25-05MP	10.0	14.0
RMH25-06MP	12.5	16.5
RMH25-07MP	15.0	19.0

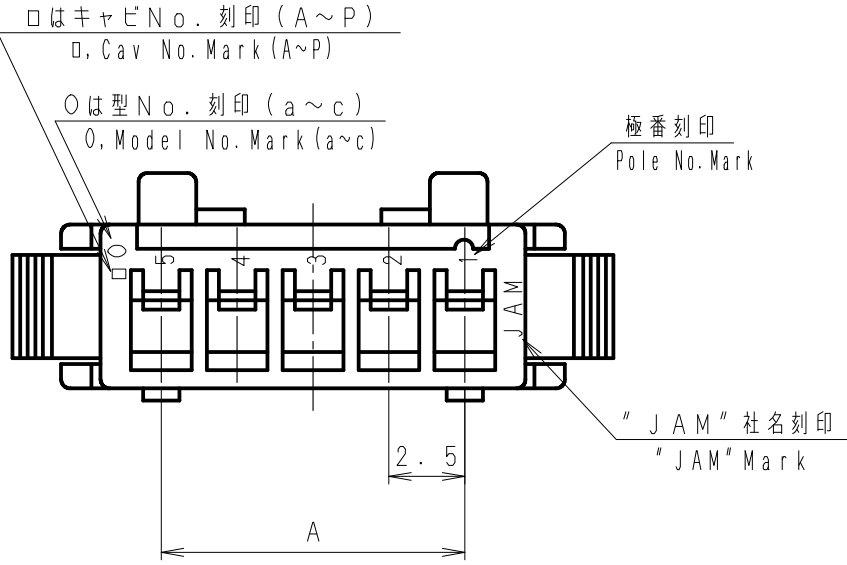
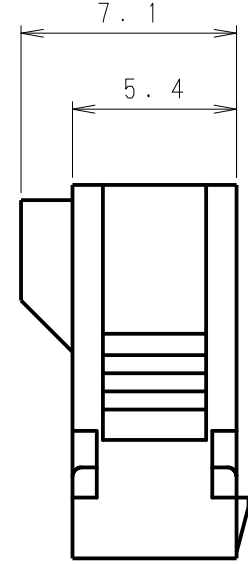
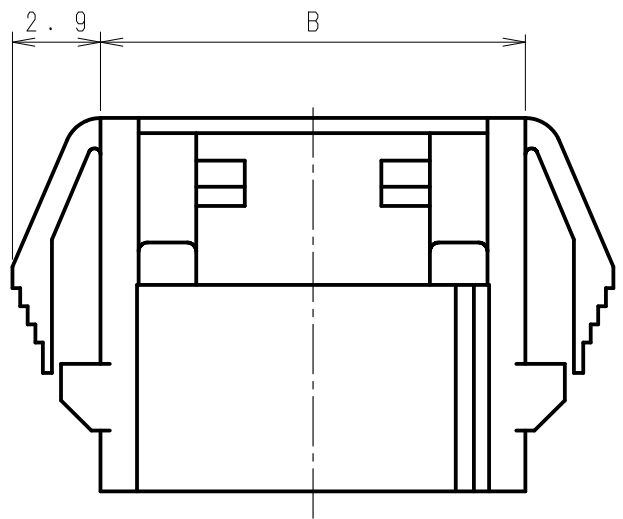
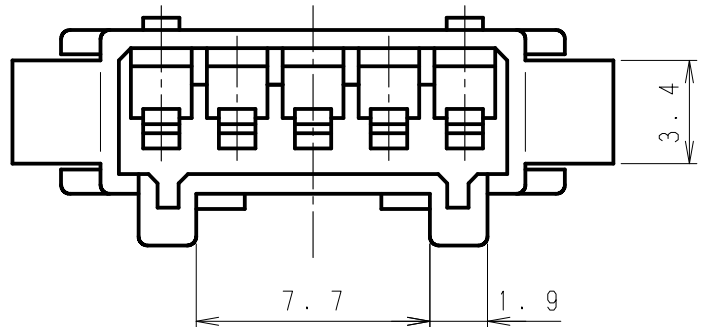

□はキャビNo. 刻印 (A~P)  
□, Cav No. Mark (A~P)

○は型No. 刻印 (a~c)  
○, Model No. Mark (a~c)

極番刻印  
Pole No. Mark

"JAM" 社名刻印  
"JAM" Mark

⑤	. . .								
④	. . .								
③	. . .				RMH25-□□MP	66ナイロン 66Nylon	UL94V-0		
②	. . .				製品番号 PRODUCT No.	材 料 MATERIAL	備考 NOTE	色 COLOR	
①	. . .								
記号 No.	年月日 DATE	変更記事 REVISION RECORD	設計 DESIGN	承認 APP	製品名 NAME		RECハウジング REC housing		
承認 APPROVED	確認 CHECKED		一般公差 TOLERANCE		尺度 SCALE	図番 DRAWING No.			
K. Koizumi	A. Kumakura		±0.3		4/1	JC-0915-14Z			
設計 DESIGN	製図 DRAWING								
N. Ogaki	N. Ogaki								

第三角法  
3rd ANGLE PROJECTION

単位: mm 注) . . . . 図面を実測しないこと  
UNIT: mm NOTES) . . . . DO NOT SCALE

図番 DRAWING No.  
JC-0915-15Z

製品番号 Product No.	A	B
RMH25-08MP	17.5	21.5
RMH25-09MP	20.0	24.0
RMH25-10MP	22.5	26.5
RMH25-11MP	25.0	29.0
RMH25-12MP	27.5	31.5
RMH25-13MP	30.0	34.0

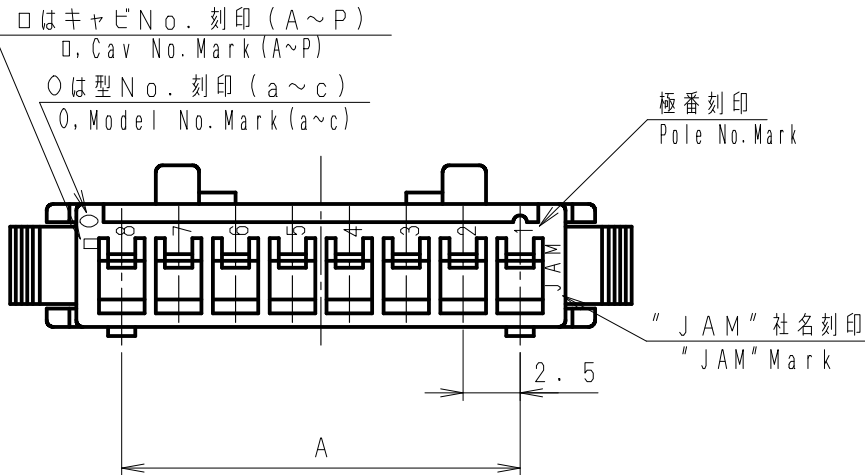
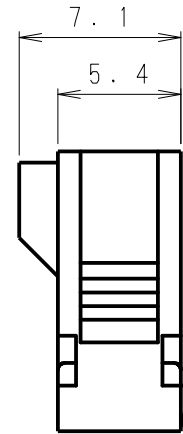
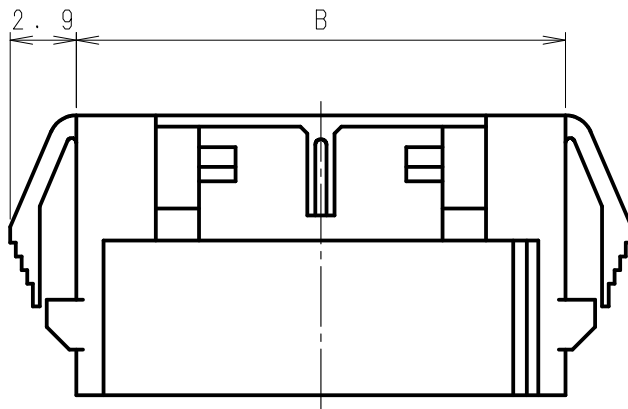
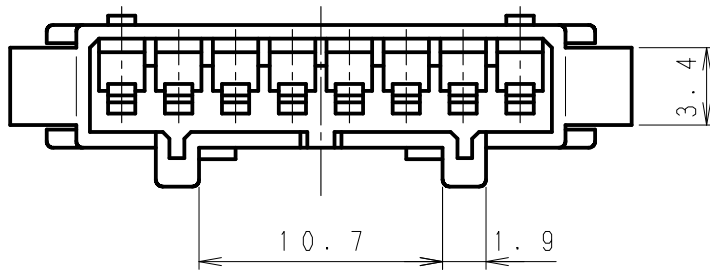

△5	. .							
△4	. .							
△3	. .				RMH25-□□MP	66ナイロン 66Nylon	UL94V-0	
△2	. .				製品番号 PRODUCT No.	材 料 MATERIAL	備考 NOTE	色 COLOR
△1	. .				No.			
記号 No.	年月日 DATE	変更記事 REVISION RECORD	設計 DESIGN	承認 APP	製品名 NAME		RECハウジング REC housing	
承認 APPROVED	確認 CHECKED		一般公差 TOLERANCE		尺度 SCALE	図番 DRAWING No.		
K. Koizumi	A. Kumakura		±0.3		3/1	JC-0915-15Z		
設計 DESIGN	製図 DRAWING							
N. Ogaki	N. Ogaki							



第三角法  
3rd ANGLE PROJECTION

単位: mm 注) . . . . 図面を実測しないこと  
UNIT: mm NOTES) . . . . DO NOT SCALE

図番 DRAWING No.  
JC-0915-26

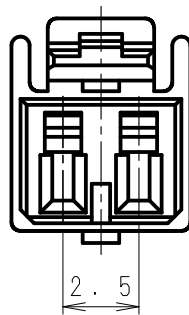
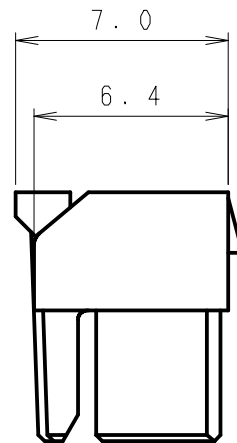
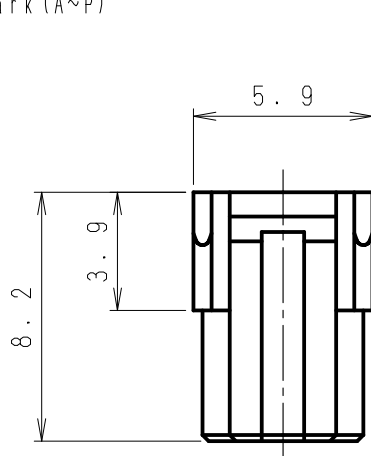
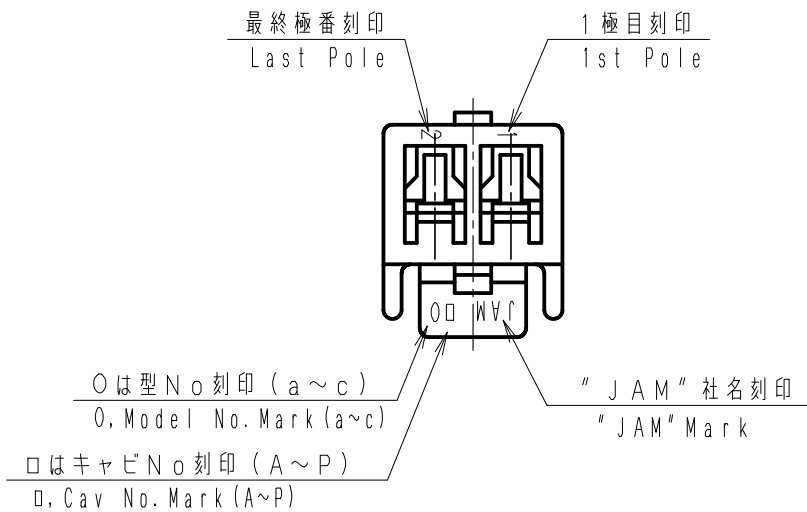

△5	. .							
△4	. .							
△3	. .				SMH25-02HG	66ナイロン 66Nylon	UL94V-0	
△2	. .				製品番号 PRODUCT No.	材 料 MATERIAL	備考 NOTE	色 COLOR
△1	. .							
記号 No.	年月日 DATE	変更記事 REVISION RECORD	設計 DESIGN	承認 APP	製品名 NAME		PLUGハウジング PLUG housing	
承認 APPROVED	確認 CHECKED	一般公差 TOLERANCE	尺度 SCALE	図番 DRAWING No.				
Y. Horiuchi	K. Koizumi	±0.3	4/1	JC-0915-26				
設計 DESIGN	製図 DRAWING	JAPAN AUTOMATIC MACHINE CO., LTD.						
N. Yarimizu	N. Yarimizu							

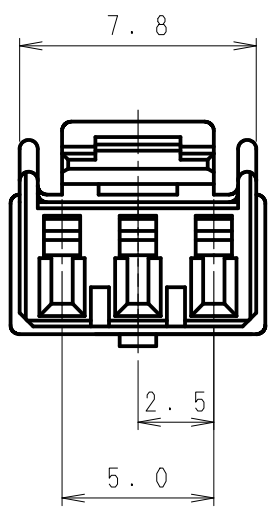
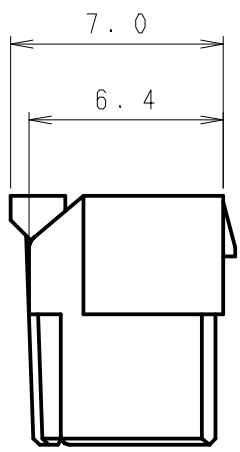
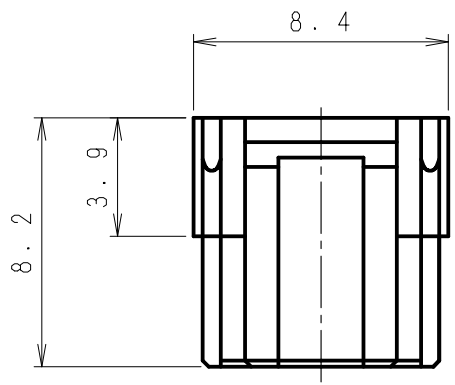
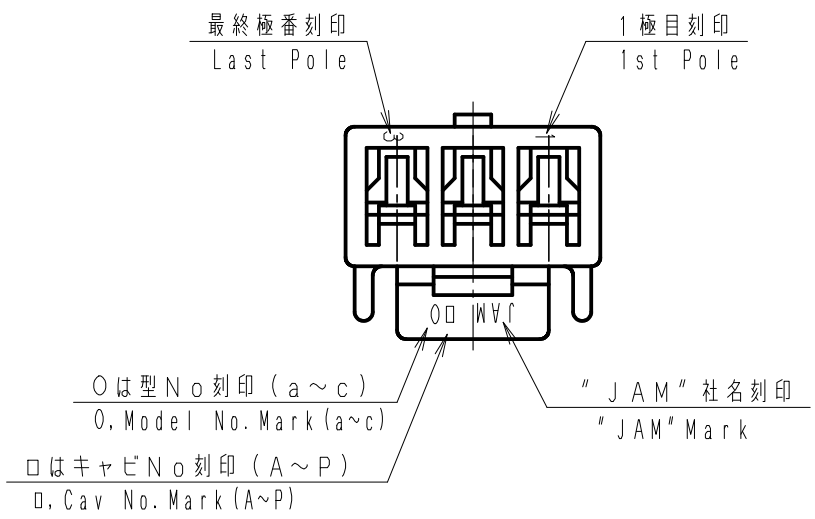

△5	. . .								
△4	. . .								
△3	. . .				SMH25-03HG	66ナイロン 66Nylon	UL94V-0		
△2	. . .				製品番号 PRODUCT No.	材 料 MATERIAL	備考 NOTE	色 COLOR	
△1	. . .								
記号 No.	年月日 DATE	変更記事 REVISION RECORD	設計 DESIGN	承認 APP	製品名 NAME		PLUGハウジング PLUG housing		
承認 APPROVED	確認 CHECKED	公差 TOLERANCE	尺度 SCALE	図番 DRAWING No.					
Y. Horiuchi	K. Koizumi	±0.3	4/1	JC-0915-27					
設計 DESIGN	製図 DRAWING	JAPAN AUTOMATIC MACHINE CO., LTD.							
N. Yarimizu	N. Yarimizu								

第三角法  
3rd ANGLE PROJECTION

単位: mm 注) . . . . 図面を実測しないこと  
UNIT: mm NOTES) . . . . DO NOT SCALE

図番 DRAWING No.  
JC-0915-28

極数 Poles	A	B
4	10.9	7.5
5	13.4	10.0
6	15.9	12.5
7	18.4	15.0

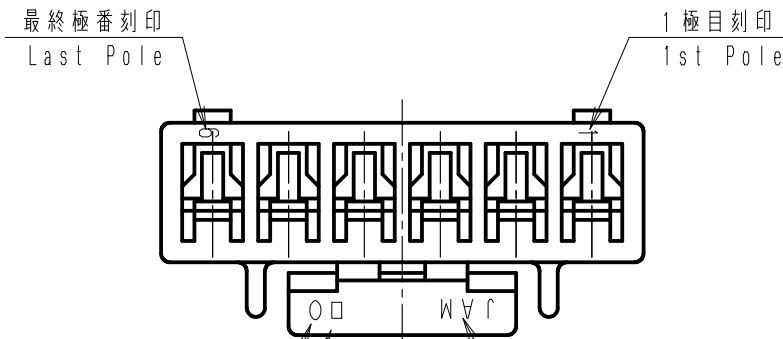

○は型No刻印 (a~c)  
O, Model No. Mark (a~c)  
□はキャビNo刻印 (A~P)  
□, Cav No. Mark (A~P)

"JAM" 社名刻印  
"JAM" Mark

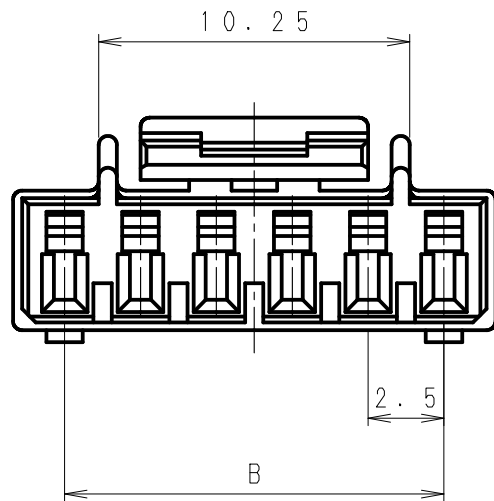
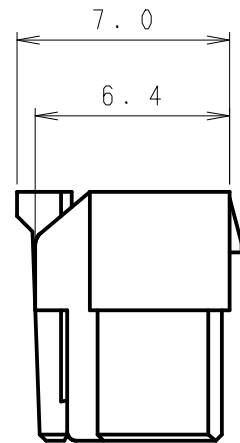
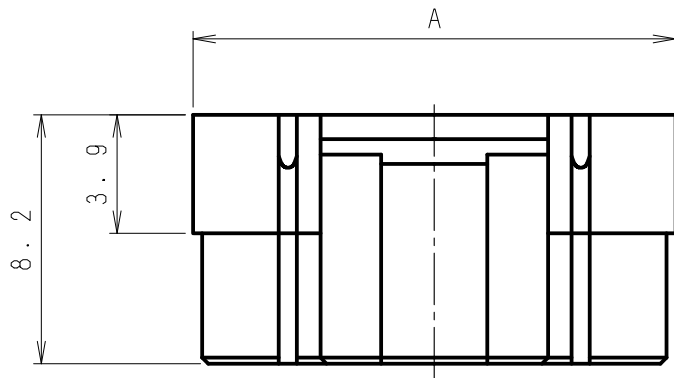

△5	. .							
△4	. .							
△3	. .				SMH25-□□HG	66ナイロン 66Nylon	UL94V-0	
△2	. .				製品番号 PRODUCT No.	No.	材 料 MATERIAL	備考 NOTE
△1	. .							色 COLOR
記号 No.	年月日 DATE	変更記事 REVISION RECORD	設計 DESIGN	承認 APP	製品名 NAME		PLUGハウジング PLUG housing	
承認 APPROVED	確認 CHECKED	一般公差 TOLERANCE	尺度 SCALE		図番 DRAWING No.			
Y. Horiuchi	K. Koizumi	±0.3	4 / 1		JC-0915-28			
設計 DESIGN	製図 DRAWING	 JAPAN AUTOMATIC MACHINE CO., LTD.						
N. Yarimizu	N. Yarimizu							

極数 Poles	A	B
8	20.9	17.5
9	23.4	20.0
10	25.9	22.5
11	28.4	25.0
12	30.9	27.5
13	33.4	30.0

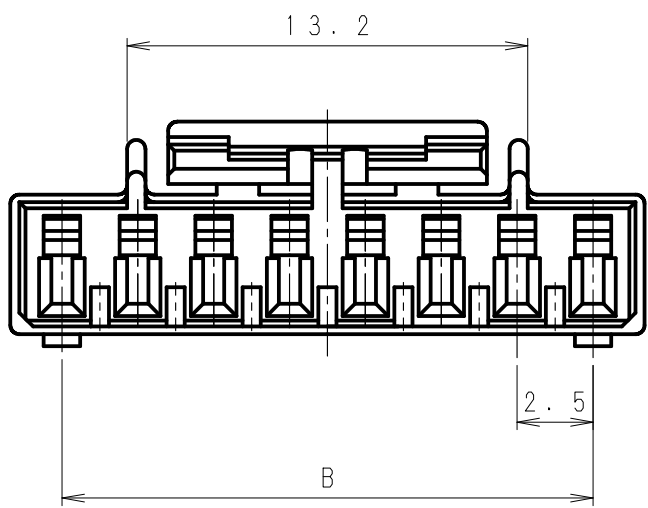
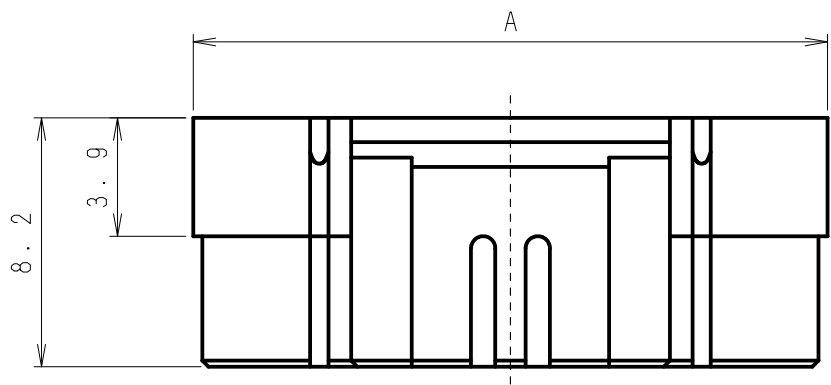
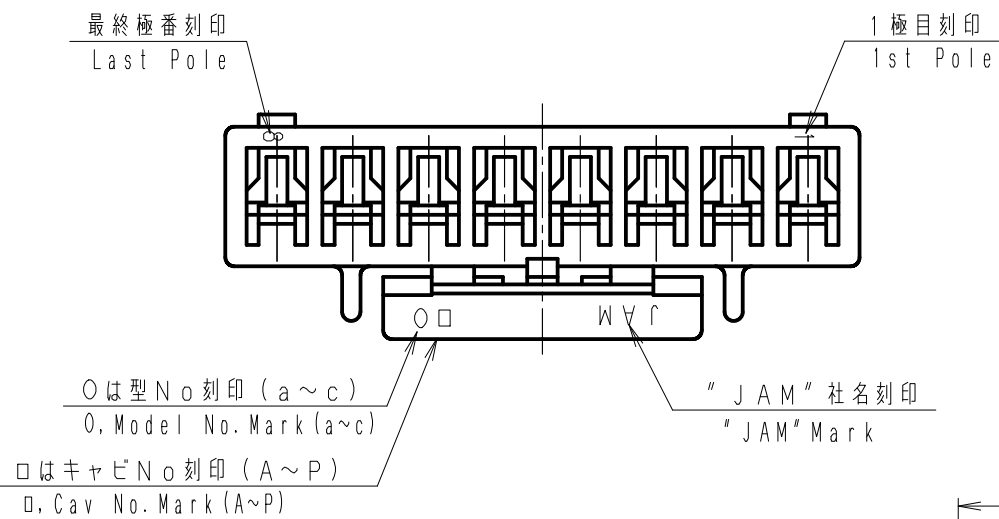

△5	. . .							
△4	. . .							
△3	. . .				SMH25-□□HG	66ナイロン 66Nylon	UL94V-0	
△2	. . .				製品番号 PRODUCT No.	材 料 MATERIAL	備考 NOTE	色 COLOR
△1	. . .							
記号 No.	年月日 DATE	変更記事 REVISION RECORD	設計 DESIGN	承認 APP	製品名 NAME		PLUGハウジング PLUG housing	
承認 APPROVED	確認 CHECKED	一般公差 TOLERANCE	尺度 SCALE	図番 DRAWING No.				
Y. Horiuchi	K. Koizumi	±0.3	4/1	JC-0915-29				
設計 DESIGN	製図 DRAWING	JAPAN AUTOMATIC MACHINE CO., LTD.						
N. Yarimizu	N. Yarimizu							

第三角法 3rd ANGLE PROJECTION      単位：mm      注) . . . . 図面を実測しないこと      図番 DRAWING No.      J C - 0 9 1 5 - 3 0  
 UNIT : mm      NOTES ) . . . . DO NOT SCALE

極数 Poles	A	B
2	5.9	2.5
3	8.4	5.0
4	10.9	7.5
5	13.4	10.0
6	15.9	12.5
7	18.4	15.0
8	20.9	17.5
9	23.4	20.0
10	25.9	22.5
11	28.4	25.0
12	30.9	27.5
13	33.4	30.0

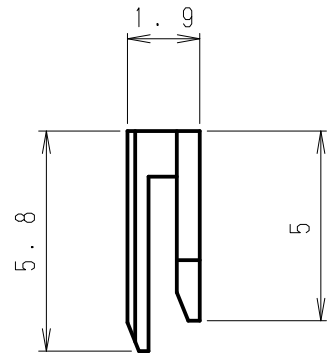
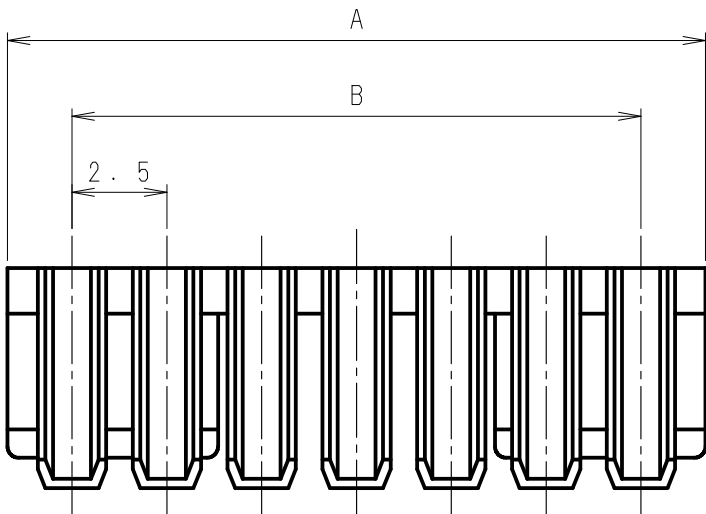
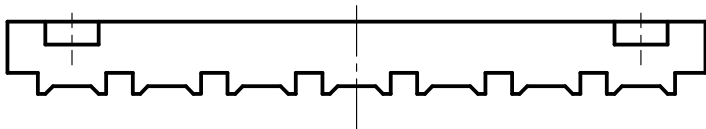

⑤	. .							
④	. .							
③	. .				RM25-00S	PBT (GF入り) PBT (With GF)	UL94V-0	
②	. .				製品番号 PRODUCT No.	材 料 MATERIAL	備考 NOTE	色 COLOR
①	. .							
記号 No.	年月日 DATE	変更記事 REVISION RECORD	設計 DESIGN	承認 APP	製品名 NAME		リテーナ Retainer	
承認 APPROVED	Y. Horiuchi	確認 CHECKED	K. Koizumi	一般公差 TOLERANCE ±0.3	尺度 SCALE	4 / 1	図番 DRAWING No.	J C - 0 9 1 5 - 3 0
設計 DESIGN	N. Yarimizu	製図 DRAWING	N. Yarimizu	 JAPAN AUTOMATIC MACHINE CO., LTD.				

第三角法  
3rd ANGLE PROJECTION

単位: mm  
UNIT: mm

注) . . . . . 図面を実測しないこと  
NOTES) . . . . . DO NOT SCALE

図番 DRAWING No.  
JC-0622-06Z

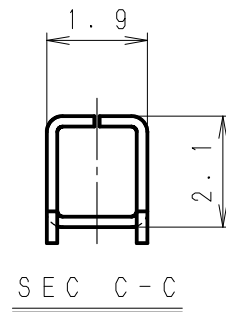
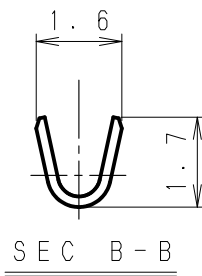
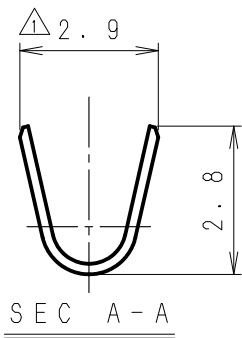
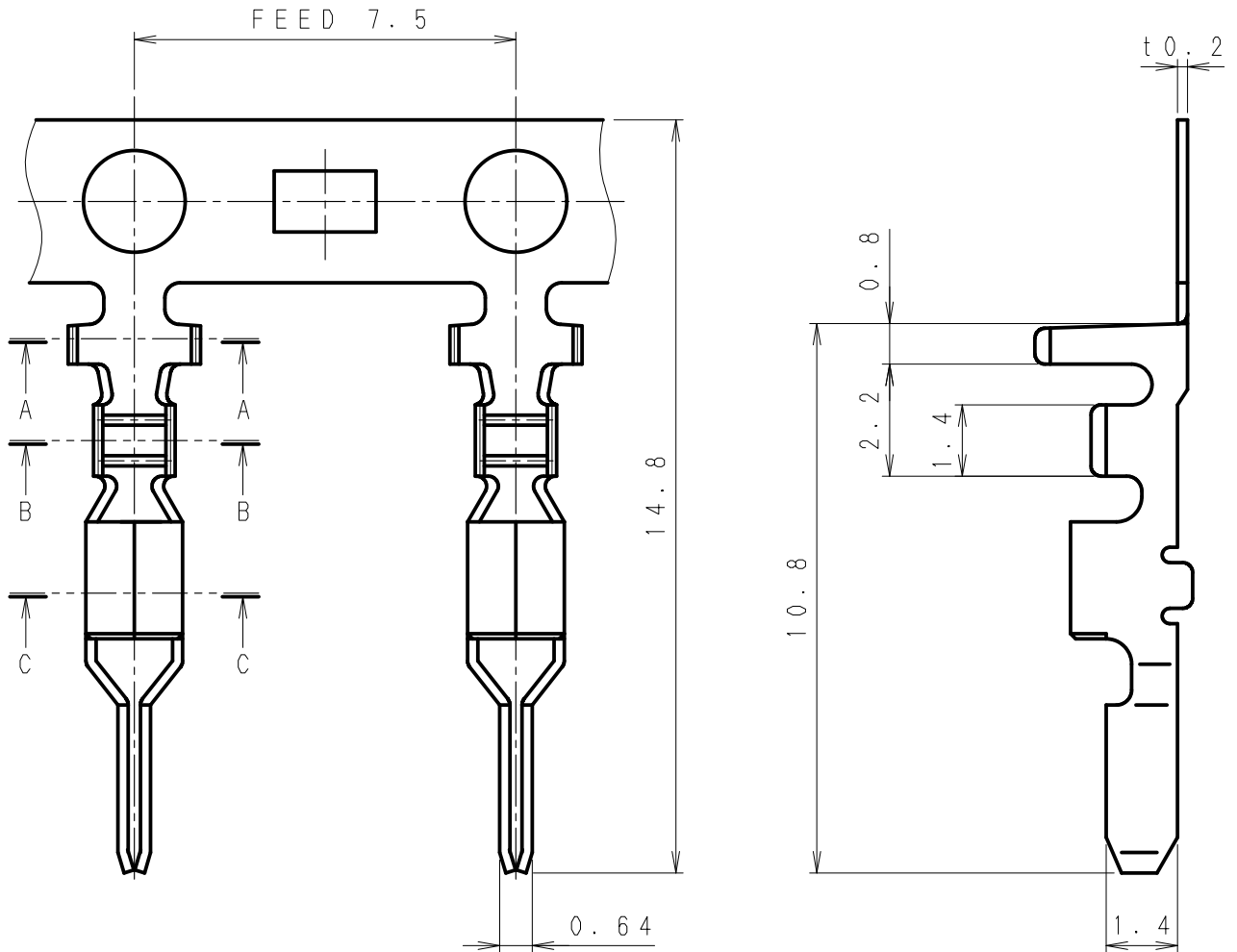

△6	. .								
△5	. .								
△4	. .				725411-2MAC	△リン青銅系又はリン青銅 Phosphor Bronze Type or Phosphor Bronze	スズメッキ材 Pre-tin Plated	AWG#22~#28	MAX φ1.7
△3	. .				製品番号 PRODUCT No.	材 料 MATERIAL	表面処理 FINISH	適用電線 WIRE SIZE	被覆外径 INSULATION DIA
△2	15. 7. 23	材質追加 Material add.	清水	草野					
△1	13. 9. 10	誤記訂正 Error correction	清水	草野					
記号 No.	年月日 DATE	変更記事 REVISION RECORD	設計 DESIGN	承認 APP	製品名 NAME		ピンコンタクト Pin Contact		
承認 APPROVED	Y. Horiuchi		確認 CHECKED		K. Kusano		一般公差 TOLERANCE	尺度 SCALE	図番 DRAWING No.
						±0.3	7/1	JC-0622-06Z	
設計 DESIGN	K. Yokoyama		製図 DRAWING		K. Yokoyama		 JAPAN AUTOMATIC MACHINE CO., LTD.		

第三角法  
3rd ANGLE PROJECTION

単位: mm 注) . . . . . 図面を実測しないこと  
UNIT: mm NOTES) . . . . . DO NOT SCALE

図番 DRAWING No.  
JC-0622-15Z

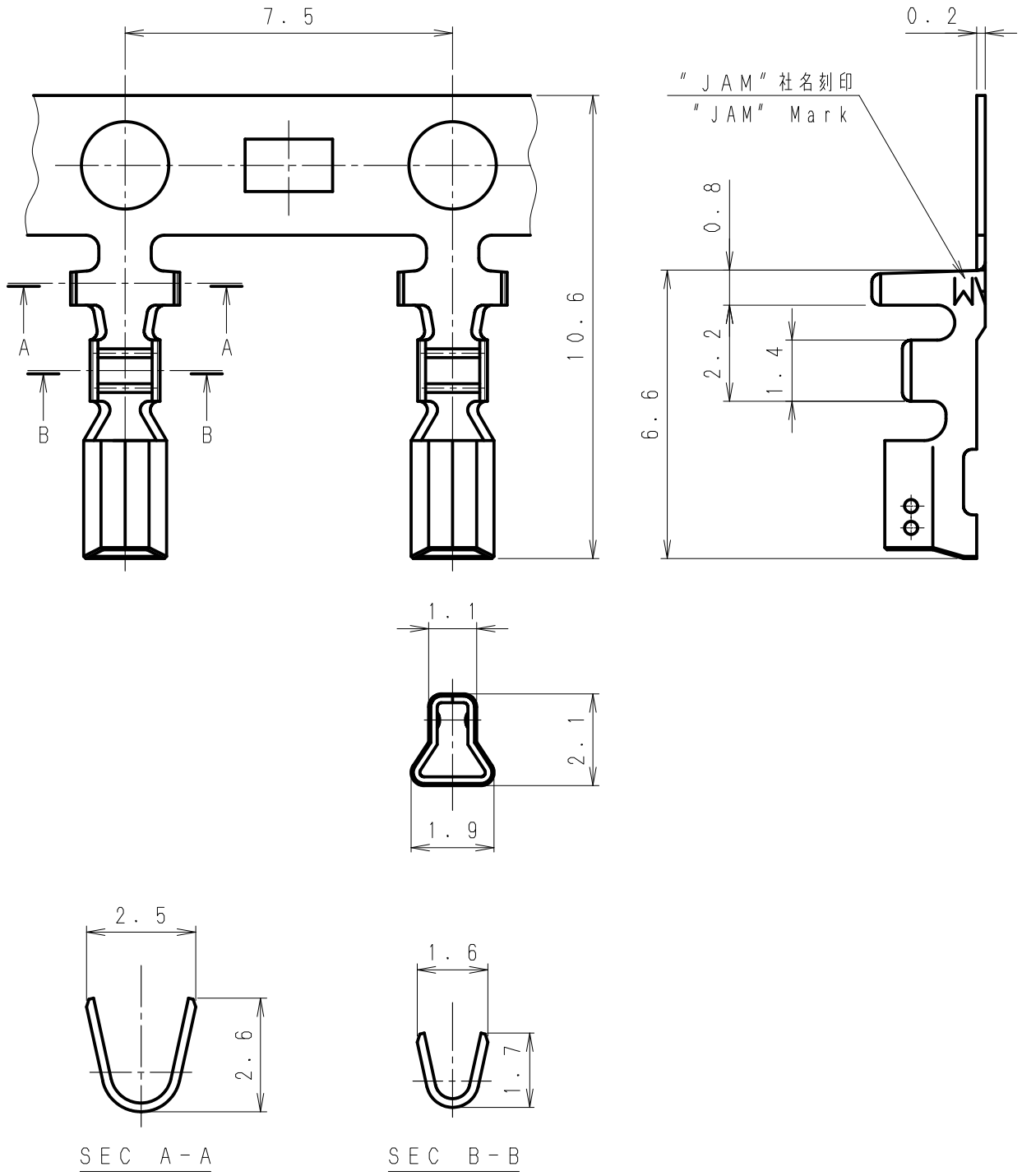

△3	. . .				725412-2MAC	リン青銅 Phosphor Bronze	スズメッキ材 Pre-tin Plated	AWG#22~#28	MAXφ1.7
△2	. . .				製品番号 PRODUCT No.	材 料 MATERIAL	表面処理 FINISH	適用電線 WIRE SIZE	被覆外径 INSULATION DIA
△1	. . .				記号 No.	年月日 DATE	変更記事 REVISION RECORD	設計 DESIGN	承認 APP
承認 APPROVED K. Kusano					確認 CHECKED T. Murakami				
設計 DESIGN Y. Shimizu					製図 DRAWING Y. Shimizu				
一般公差 TOLERANCE ±0.3					尺度 SCALE 7/1				
製品名 NAME ソケットコンタクト Socket contact					図番 DRAWING No. JC-0622-15Z				

第三角法  
3rd ANGLE PROJECTION

単位: mm 注) . . . . 図面を実測しないこと  
UNIT: mm NOTES) . . . . DO NOT SCALE

図番 DRAWING No.  
JC-0915-16Z

2P用パネル寸法

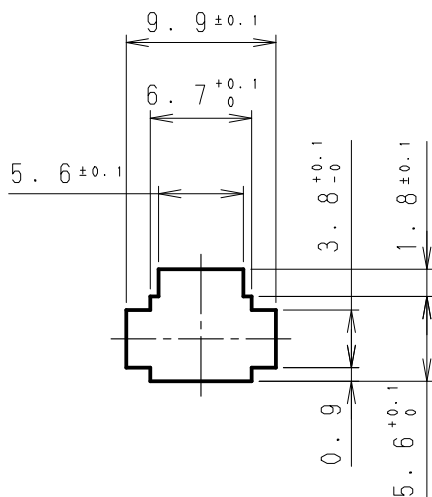

極数 Poles	A	B	C	D	E
3	9.2	12.4	—	—	—
4	11.7	14.9	—	—	—
5	—	—	14.2	17.4	11.9
6	—	—	16.7	19.9	11.9
7	—	—	19.2	22.4	11.9
8	—	—	21.7	24.9	14.9
9	—	—	24.2	27.4	14.9
10	—	—	26.7	29.9	14.9
11	—	—	29.2	32.4	14.9
12	—	—	31.7	34.9	14.9
13	—	—	34.2	37.4	14.9

3~4P用パネル寸法

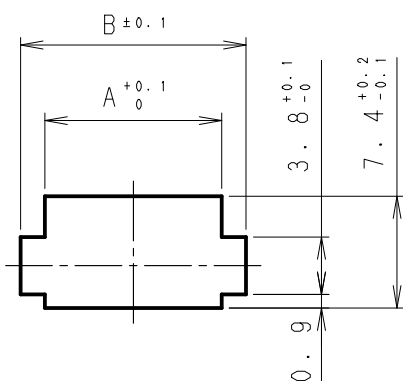

5~13P用パネル寸法

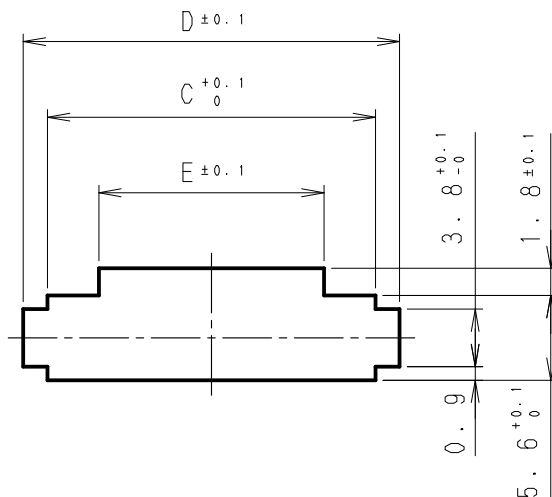

注記 Note

- 1) 適用パネル厚: 1.0~2.0mm。  
Application panel thickness: 1.0mm to 2.0mm.
- 2) パネル穴にバリのなきこと。  
There must not be "BURR" in the panel hole.
- 3) パネル穴抜打ちの場合は、ハウジング挿入側がダレ側となる方向に打抜きのこと。  
Pierce a punch of a panel hole from a REC housing insertion side.

△6	. .								
△5	. .								
△4	. .								
△3	. .								
△2	. .				製品番号 PRODUCT No.	No.	材 料 MATERIAL	備考 NOTE	色 COLOR
△1	. .								
記号 No.	年月日 DATE	変更記事 REVISION RECORD	設計 DESIGN	承認 APP	製品名 RMHコネクタ 取り付けハ°ネル寸法 NAME RMH Connector attachment panel size				
承認 APPROVED K. Koizumi		確認 CHECKED T. Murakami		一般公差 TOLERANCE ±0.3	尺度 SCALE 3/1	図番 DRAWING No. JC-0915-16Z			
設計 DESIGN N. Ogaki		製図 DRAWING N. Ogaki							