

第三角法  
3rd ANGLE PROJECTION

単位: mm  
UNIT: mm  
注) . . . . . 図面を実測しないこと  
NOTES) . . . . . DO NOT SCALE

図番 DRAWING No.  
JC-1079-17

Poles	A	B	Poles	A	B
8	18.0	14.0	13	28.0	24.0
9	20.0	16.0	14	30.0	26.0
10	22.0	18.0	15	32.0	28.0
11	24.0	20.0	16	34.0	30.0
12	26.0	22.0	—	—	—

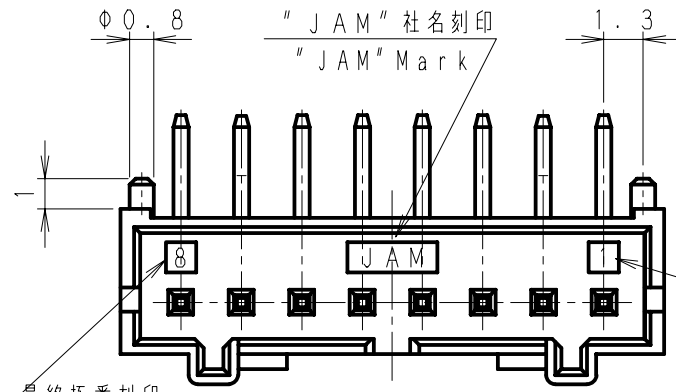

極番刻印  
Pole No. Mark

最終極番刻印  
Last Pole No. Mark

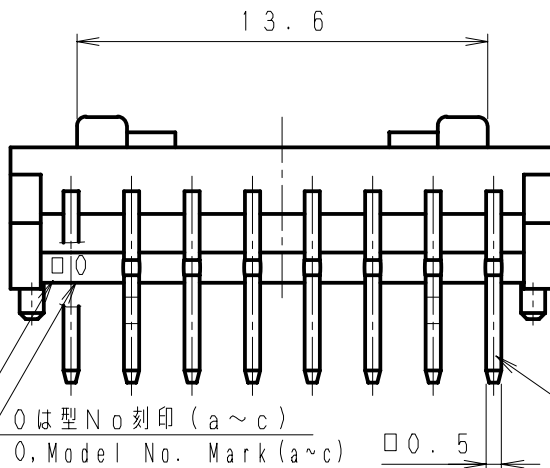
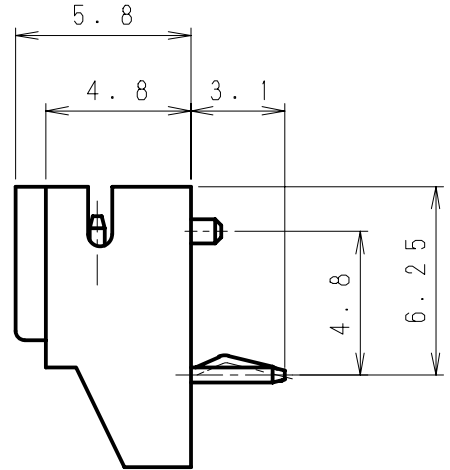
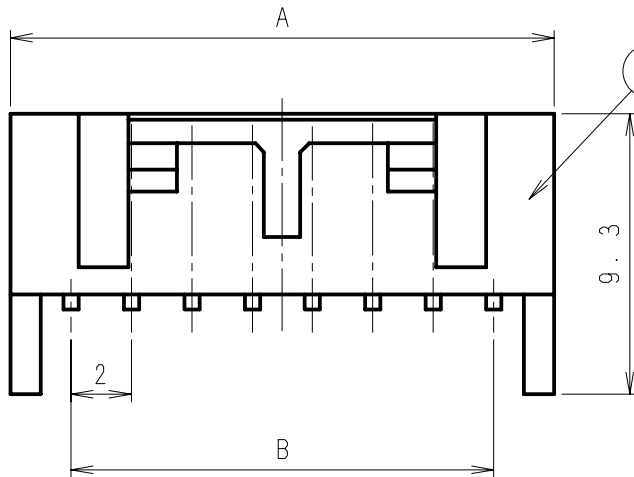

○は型No刻印 (a~c)  
○, Model No. Mark (a~c)  
□はキャビNo刻印 (A~P)  
□, Cav No. Mark (A~P)

△6	. .								
△5	. .								
△4	. .								
△3	. .								
△2	. .								
△1	. .								
記号 No.	年月日 DATE	変更記事 REVISION RECORD	設計 DESIGN	承認 APP	製品番号 PRODUCT No.	材料 MATERIAL	備考 NOTE	色 COLOR	
承認 APPROVED	K. Kusano	確認 CHECKED	A. Kumakura	一般公差 TOLERANCE	±0.3	尺度 SCALE	4/1	製品名 NAME	SJHウエハー (ボス付 アングル型) SJH Wafer, Angle type with boss
設計 DESIGN	A. Kumakura	製図 DRAWING	Y. Shimizu	図番 DRAWING No.	JC-1079-17				

**JAPAN AUTOMATIC MACHINE CO., LTD.**