

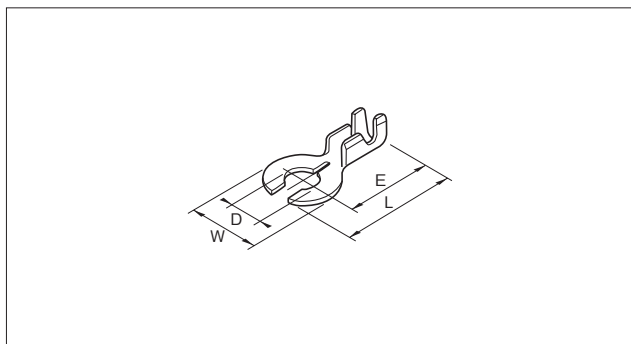

クワ形

SPADE TERMINAL



品番 Part No.	電線サイズ Wire Size		材質 Material	板厚 Thickness	D	L	W	E	個数/リール PCS/Reel	アプリケーション Applicator	備考 Reference
	AWG	断面積(mm ²) Sectional area(mm ²)									
160700-0	#14~#20	0.5~2.0	黄銅 Brass	0.8	φ6.4	24.0	12.0	18.7	3,000×3R	J-3700A	LE-106
160700-2	#14~#20	0.5~2.0	黄銅 Brass	0.8	φ6.4	24.0	12.0	18.7	3,000×3R	J-3700A	LE-106

注) 表面処理については「表面処理分類表(P225)」を参照ください。
 Notice) Finishing code is available to see attached "Finishing Classification(P225)"



平形110単極用REC

REC FOR FLAT TERMINAL 110 SINGLE-POLE

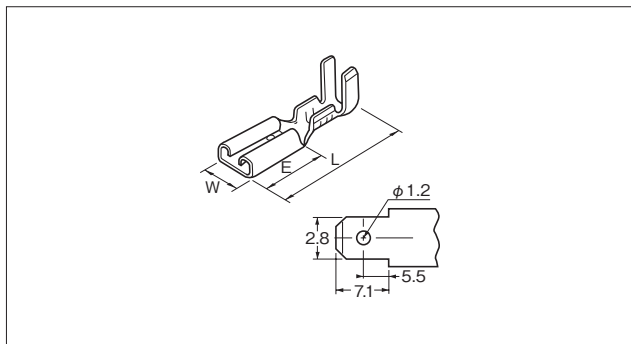

品番 Part No.	電線サイズ Wire Size		材質 Material	板厚 Thickness	L	W	E	個数/リール PCS/Reel	アプリケーション Applicator	備考 Reference
	AWG	断面積(mm ²) Sectional area(mm ²)								
211022-2	#16~#20	0.5~1.25	黄銅 Brass	0.25	15.4	3.7	6.12	10,000×3R	MCE-300	適合TAB厚0.5 (Mating TAB)
211022-2M	#16~#20	0.5~1.25	黄銅 Brass	0.25	15.4	3.7	6.12	10,000×3R	MCE-300	適合TAB厚0.5 (Mating TAB)
211022-2MA	#16~#20	0.5~1.25	黄銅 Brass	0.25	15.4	3.7	6.12	10,000×3R	MCE-300	適合TAB厚0.5 (Mating TAB)
※211022-2N	#16~#20	0.5~1.25	黄銅 Brass	0.25	15.4	3.7	6.12	10,000×3R	MCE-300	適合TAB厚0.5 (Mating TAB)
211022-2N-A	#16~#20	0.5~1.25	黄銅 Brass	0.25	15.4	3.7	6.12	10,000×3R	MCE-300	適合TAB厚0.5 (Mating TAB)
211032-2	#22~#24	0.2~0.33	黄銅 Brass	0.25	15.4	3.7	6.12	10,000×3R	MCE-300-A	適合TAB厚0.5 (Mating TAB)
※211032-2N	#22~#24	0.2~0.33	黄銅 Brass	0.25	15.4	3.7	6.12	10,000×3R	MCE-300-A	適合TAB厚0.5 (Mating TAB)
211032-2N-A	#22~#24	0.2~0.33	黄銅 Brass	0.25	15.4	3.7	6.12	10,000×3R	MCE-300-A	適合TAB厚0.5 (Mating TAB)
211082-0	#16~#20	0.5~1.25	黄銅 Brass	0.25	15.4	3.7	6.12	10,000×3R	MCE-300	適合TAB厚0.8 (Mating TAB)

※2N: UL規格取得 Approved(UL File No.E1118059)

注) 表面処理については「表面処理分類表(P225)」を参照ください。
 Notice) Finishing code is available to see attached "Finishing Classification(P225)"