

RoHS

平形250多極用REC (ケースランス用)

REC FOR FLAT TERMINAL 250 MULTI-POLES (for case lance)

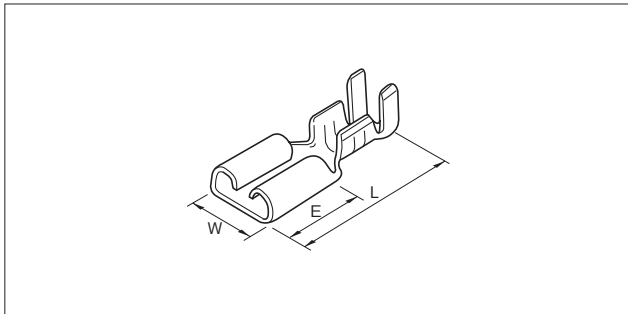

品番 Part No.	電線サイズ Wire Size		材質 Material	板厚 Thickness	L	W	E	個数/リール PCS/Reel	アプリケーション Applicator	備考 Reference
	AWG	断面積(mm ²) Sectional area (mm ²)								
225502-2M	#14~#20	0.5~2.0	黄銅 Brass	0.32	19.4	7.5	7.75	12,000×2R	MCE-500	

RoHS

ギボシ形PLUG

BULLET TERMINAL PLUG

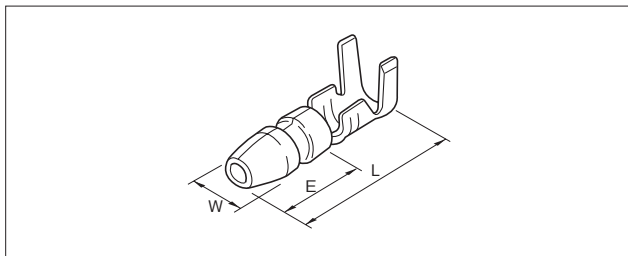

品番 Part No.	電線サイズ Wire Size		材質 Material	板厚 Thickness	L	W	E	個数/リール PCS/Reel	アプリケーション Applicator	備考 Reference
	AWG	断面積(mm ²) Sectional area (mm ²)								
300501-0	#14~#20	0.5~2.0	黄銅 Brass	0.5	17.3	φ3.96	8.8	7,000×3R	MCE-100	CA-104
300501-2	#14~#20	0.5~2.0	黄銅 Brass	0.5	17.3	φ3.96	8.8	7,000×3R	MCE-100	CA-104
300541-2	#22~#24	0.2~0.35	黄銅 Brass	0.5	17.3	φ3.96	8.8	7,000×3R	MCE-11300	

RoHS

ギボシ形REC

BULLET TERMINAL REC

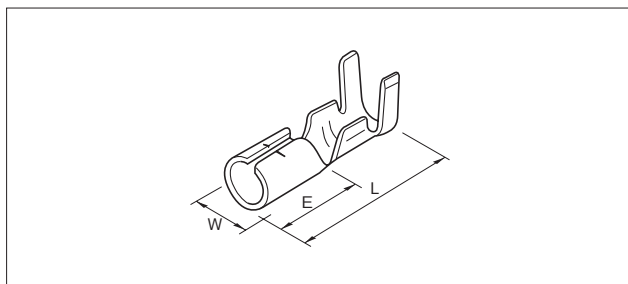

品番 Part No.	電線サイズ Wire Size		材質 Material	板厚 Thickness	L	W	E	個数/リール PCS/Reel	アプリケーション Applicator	備考 Reference
	AWG	断面積(mm ²) Sectional area (mm ²)								
300502-0	#14~#20	0.5~2.0	黄銅 Brass	0.4	17.6	φ4.6	6.5	7,000×3R	MCE-100-A	CB-104
300502-2	#14~#20	0.5~2.0	黄銅 Brass	0.4	17.6	φ4.6	6.5	7,000×3R	MCE-100-A	CB-104
300542-2	#22~#24	0.2~0.35	黄銅 Brass	0.4	17.6	φ4.6	6.5	7,000×3R	MCE-11300-A	

注) 表面処理については「表面処理分類表(P236)」を参照ください。

Notice) Finishing code is available to see attached "Finishing Classification(P236)"