

平形110多極用TAB

TAB FOR FLAT TERMINAL 110 MULTI-POLES

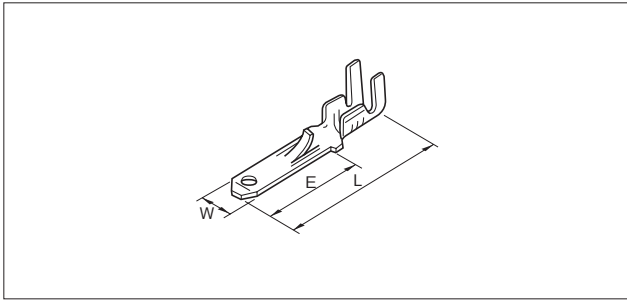

品番 Part No.	電線サイズ Wire Size		材質 Material	板厚 Thickness	L	W	E	個数/リール PCS/Reel	アプリケーション Applicator	備考 Reference
	AWG	断面積(mm ²) Sectional area(mm ²)								
211011-0	#16~#20	0.5~1.25	黄銅 Brass	0.5	20.4	2.79	12.0	7,000×3R	MCE-200	
211011-0A	#16~#20	0.5~1.25	黄銅 Brass	0.5	20.4	2.79	12.0	7,000×3R	MCE-200	
211031-0A	#22~#24	0.2~0.33	黄銅 Brass	0.5	20.4	2.79	12.0	8,000×3R	MCE-2400	

適合REC (Mating REC): 211012

平形110多極用REC

REC FOR FLAT TERMINAL 110 MULTI-POLES

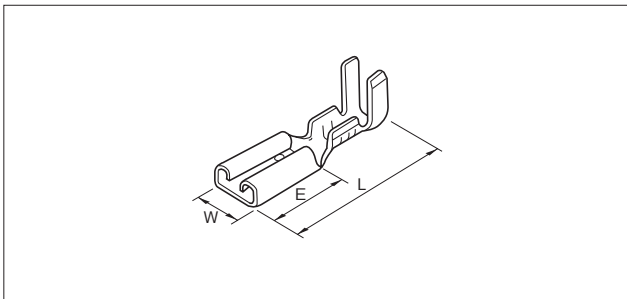

品番 Part No.	電線サイズ Wire Size		材質 Material	板厚 Thickness	L	W	E	個数/リール PCS/Reel	アプリケーション Applicator	備考 Reference
	AWG	断面積(mm ²) Sectional area(mm ²)								
211012-0	#16~#20	0.5~1.25	黄銅 Brass	0.25	15.4	3.7	6.12	10,000×3R	MCE-300	
211012-2MA	#16~#20	0.5~1.25	黄銅 Brass	0.25	15.4	3.7	6.12	10,000×3R	MCE-300	

適合TAB (Mating TAB): 211011, 211031

注) 表面処理については「表面処理分類表(P236)」を参照ください。

Notice) Finishing code is available to see attached "Finishing Classification(P236)"